



## INSTALLATION AND MAINTENANCE INSTRUCTIONS

# MODEL MDWF DOUBLE WALL FLEXIBLE CONNECTORS



THIS SYMBOL ON THE NAMEPLATE MEANS THE PRODUCT IS LISTED BY UNDERWRITERS LABORATORIES.  
LISTING NO. MH 17528  
(FOR CHIMNEY LINERS)  
LISTING NO. MH 25730  
(FOR VENT CONNECTORS)

### CAUTION:

Clearances for Metal-Fab double wall flexible connector to unprotected combustible material is 1" in an unenclosed installation. Metal-Fab double wall flexible connector has been designed to properly connect Category I gas-burning appliances to listed chimney lining systems or listed Type-B gas vent. Category I appliances operate with a non-positive vent static pressure and with a vent temperature that avoids excessive condensate production in the vent. Appliances burning solid or liquid fuels, or Category II, III or IV furnaces, are not to be connected to this flex connector.

Do not fully enclose or pass through combustible areas such as walls, ceilings or floors. If connecting to a flexible chimney liner, refer to the "Minimum Appliance Clearances" specified in NFPA 211.

### APPLICATIONS:

Metal-Fab Model MDWF is an air insulated double wall connector system with comparable insulating value to Type-B gas vent. The Model MDWF may be used where Type-B gas vent connectors are required and must be sized to that specified in the appliance manufacturers instructions or follow the Category I venting tables used for sizing Type-B gas vent contained in the National Fuel Gas Code (NFPA 54 / ANSI Z223.1).

Metal-Fab Model MDWF may be installed in an unenclosed space between the appliance and the listed masonry chimney system or Type-B gas vent. This flexible connector may also be used as a segment of Type-B gas vent in an attic or crawl space. Contact local building or fire officials about restrictions and installations in your area.

Metal-Fab Model MDWF can be universally used on same-sized Type-B gas vents manufactured by the following:

- M&G Duravent (Duravent)
- American Metal (Amerivent)
- Hart and Cooley (Metlvent)
- Continental Industries (Airjet)
- Mitchell Metal Products Inc. (Mitchvent)
- Metalbest & Airmate (Household Manufacturing)

When connecting the male end of Model MDWF into other brand Type-B gas vent, no additional adapters are necessary. Simply insert the Model MDWF male connector end, 3/4" - 1 1/2", into the female connector end of the vents listed above. Secure joint with (3) 1/4" metal screws at approximately 120° apart. Do not penetrate the flue with screws.

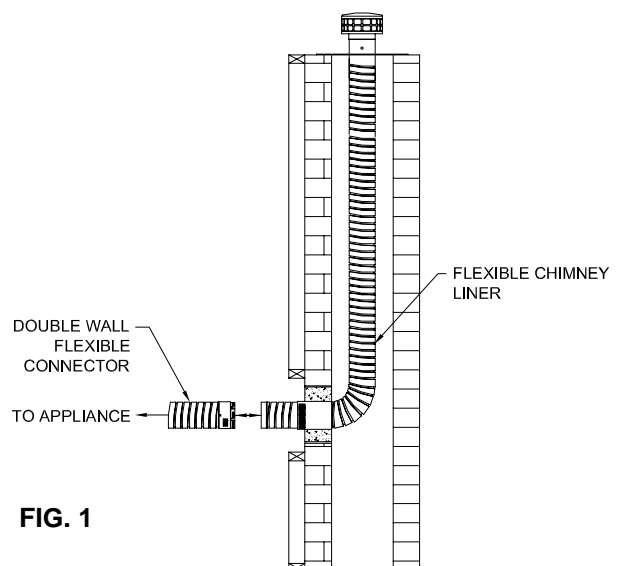
For connecting the female end of the Model MDWF to other brands listed above, use the universal adapter (Model MA) and refer to installation instructions supplied with adapter.

While installing flexible connectors, consideration should be given to the following:

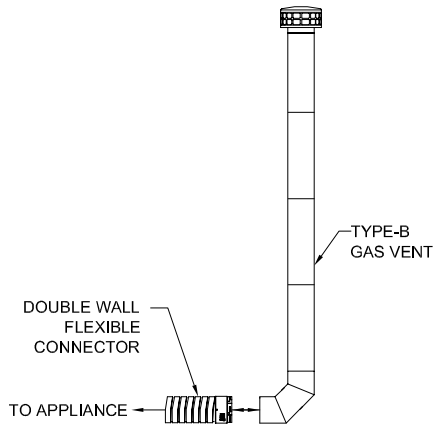
1. Make no unnecessary bends
2. Make no bends greater than 90 degrees
3. Make bends as smooth as possible, with no dips or sags, and
4. Install with at least a 1/4" per foot rise

### INSTALLATION:

1. Determine the length of the connector needed to connect an appliance to:
  - a. Inlet of listed chimney lining system, or
  - b. inlet of Type-B gas vent pipe, Tee, or "Y".
2. Never cut or modify the flexible connector length. Choose connector lengths which provide the proper overall length. Length can be reduced slightly by compressing the flexible connector. Two or more connectors can be joined together to increase the length.
3. Twist lock the outlet (top end of the connector to):
  - a. The inlet of the chimney lining system, (See **FIG. 1**)
  - b. Inlet of the Type-B gas vent system (See **FIG. 2**), or
  - c. Inlet end of Type-B gas vent Tee or "Y" (See **FIG. 3**).

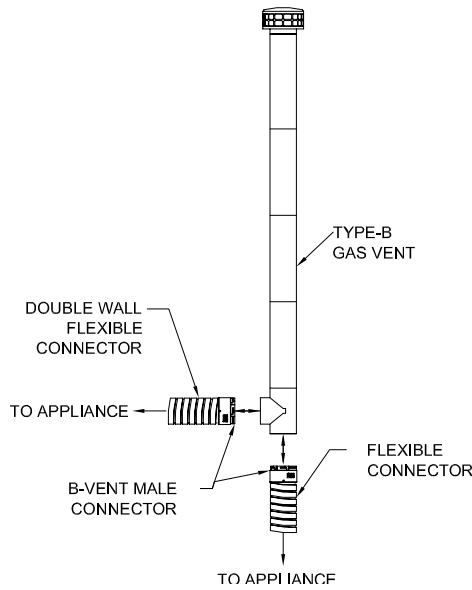


**FIG. 2**

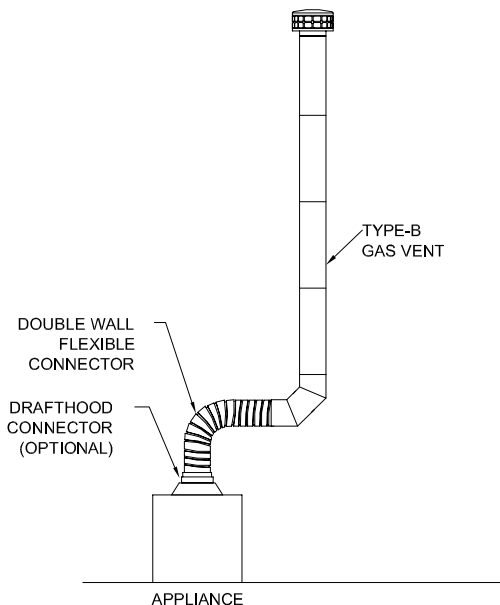


**FIG. 3**

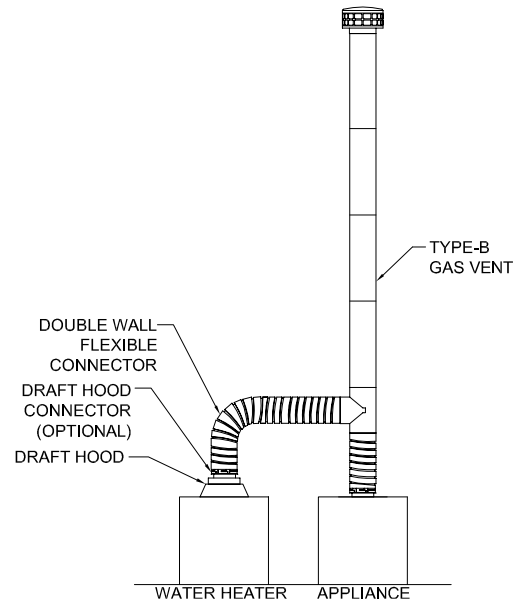
4. Form the flexible connector(s) into the configuration that enables connection to:
- A single appliance (See **FIG. 4**) or
  - Multiple appliances (See **FIG. 5**).
- Be careful not to make any abrupt or sharp bends or create bends greater than 90 degrees.



**FIG. 4**

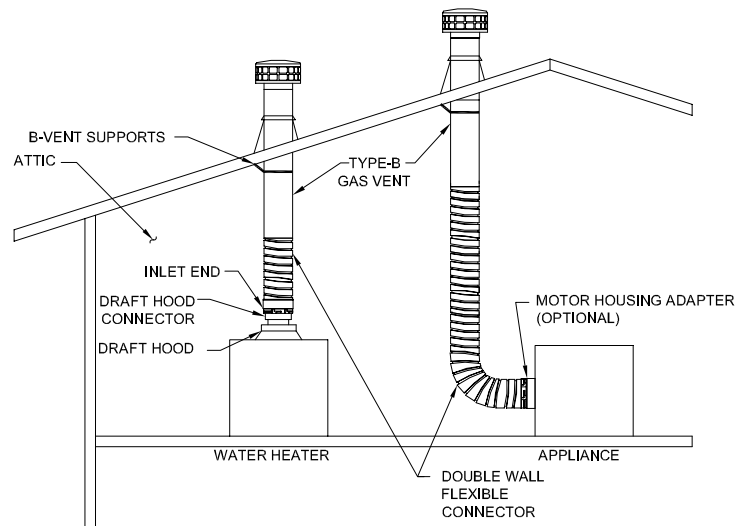


LITHO IN U.S.A



**FIG. 5**

5. When used as a segment of Type-B gas vent in an unenclosed area, such as an attic or crawl space, install the double wall flexible connectors shown in **FIG. 6**.



**FIG. 6**

6. After making all connections, check the system for soundness of connections and compliance with clearance to combustibles.

**MAINTENANCE INSTRUCTIONS:**

A qualified person should check the flexible connector at least once per year following initial installation, to insure connections are tight and the flexible connector has not sagged.



P.O Box 1138 • Wichita, KS 67201  
(316) 943-2351 • FAX (316) 943-2717