



Heating & Air Conditioning

# INSTALLATION INSTRUCTIONS

## 14 SEER

### Split System Heat Pump & Air Conditioner

### 1.5-5 Tons

### R410A

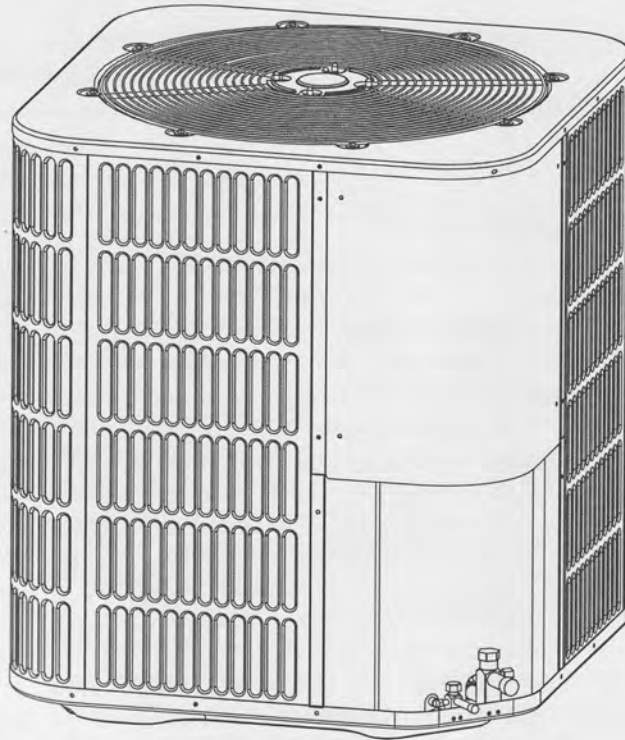

**NOTE:** Appearance of unit may vary.



**RECOGNIZE THIS SYMBOL AS AN INDICATION OF IMPORTANT SAFETY INFORMATION**

#### **WARNING**

These instructions are intended as an aid to qualified licensed service personnel for proper installation, adjustment and operation of this unit. Read these instructions thoroughly before attempting installation or operation. Failure to follow these instructions may result in improper installation, adjustment, service or maintenance possibly resulting in fire, electrical shock, property damage, personal injury or death.



**DO NOT DESTROY THIS MANUAL**

Please read carefully and keep in a safe place for future reference by a serviceman.

# TABLE OF CONTENTS

<b>1.0 SAFETY</b> .....	<b>3</b>
1.1 INSPECTION.....	4
1.2 LIMITATIONS.....	4
<b>2.0 GENERAL</b> .....	<b>4</b>
<b>3.0 UNIT INSTALLATION</b> .....	<b>6</b>
3.1 LOCATION.....	6
3.2 GROUND INSTALLATION.....	6
3.3 ROOF INSTALLATION.....	6
3.4 UNIT PLACEMENT.....	6
3.5 UNIT MOUNTING.....	7
3.6 FACTORY-PREFERRED TIE-DOWN METHOD.....	8
3.7 PRECAUTIONS DURING LINE INSTALLATION.....	9
3.8 PRECAUTIONS DURING BRAZING OF LINES.....	10
3.9 PRECAUTIONS DURING BRAZING SERVICE VALVE.....	10
<b>4.0 INTERCONNECTING TUBING</b> .....	<b>12</b>
4.1 SUCTION AND LIQUID LINES .....	12
4.2 MAXIMUM LENGTH OF LINES .....	12
4.3 VERTICAL LIFT .....	12
<b>5.0 EVACUATION</b> .....	<b>12</b>
<b>6.0 ELECTRICAL CONNECTIONS</b> .....	<b>14</b>
6.1 GENERAL INFORMATION & GROUNDING .....	14
6.2 FIELD CONNECTIONS POWER WIRING .....	14
6.3 REMOVING THE TOP PANEL AND MOTOR.....	15
<b>7.0 SYSTEM OPERATION</b> .....	<b>15</b>
7.1 COMPRESSOR CRANKCASE HEATER (CCH).....	15
7.2 REVERSING VALVE INTRODUCTION .....	15
7.3 PROTECTION FUNCTION INTRODUCTION.....	16
7.4 DEFROST MODE INTRODUCTION.....	16
<b>8.0 CHECKING REFRIGERANT CHARGE</b> .....	<b>17</b>
8.1 CHARGING BY LIQUID PRESSURE.....	17
8.2 CHARGING BY WEIGHT .....	17
8.3 FINAL LEAK TESTING .....	17
<b>9.0 WARRANTY</b> .....	<b>18</b>
<b>10.0 WIRING DIAGRAM</b> .....	<b>18</b>
10.1 CONTROL WIRING FOR A/C UNITS.....	18
10.2 CONTROL WIRING FOR H/P UNITS .....	19

This document is customer property and is to remain with this unit. These instructions do not cover all the different variations of systems nor does it provide for every possible contingency to be met in connection with installation.

All phases of this installation must comply with NATIONAL, STATE, AND LOCAL CODES. If additional information is required please contact your local distributor.

## 1.0 SAFETY



This is a safety alert symbol. When you see this symbol on labels or in manuals, be alert to the potential for personal injury.



This is an attention alert symbol. When you see this symbol on labels or in manuals, be alert to the potential for personal injury.

Understand and pay particular attention to the signal words DANGER, WARNING, or CAUTION.

DANGER indicates an imminently hazardous situation, which, if not avoided, will result in death or serious injury.

WARNING indicates a potentially hazardous situation, which, if not avoided, could result in death or serious injury.

CAUTION indicates a potentially hazardous situation, which, if not avoided may result in minor or moderate injury. It is also used to alert against unsafe practices and hazards involving only property damage.



### WARNING

Improper installation may create a condition where the operation of the product could cause personal injury or property damage.

Improper installation, adjustment, alteration, service or maintenance can cause injury or property damage. Refer to this manual for assistance or for additional information, consult a qualified contractor, installer or service agency.



### CAUTION

This product must be installed in strict compliance with the installation instructions and any applicable local, state, and national codes including, but not limited to building, electrical, and mechanical codes.



### WARNING

#### FIRE OR ELECTRICAL HAZARD

Failure to follow the safety warnings exactly could result in serious injury, death or property damage.

A fire or electrical hazard may result causing property damage, personal injury or loss of life.



### CAUTION

If using existing refrigerant lines make certain that all joints are brazed, not soldered.



### CAUTION

Scroll compressor dome temperatures may be hot. Do not touch the top of compressor; it may cause minor to severe burning.

## 1.1 INSPECTION

As soon as a unit is received, it should be inspected for possible damage during transit. If damage is evident, the extent of the damage should be noted on the carrier's delivery receipt. A separate request for inspection by the carrier's agent should be made in writing. See Local distributor for more information.

### Requirements For Installing/Serviceing R410A Equipment

- Gauge sets, hoses, refrigerant containers, and recovery system must be designed to handle the POE or PVE type oils.
- Manifold sets should be 800 PSIG high side and 250 PSIG low side with 550 PSIG low side restart.
- All hoses must have a 700 PSIG service pressure rating.
- Leak detectors should be designed to detect R410A.
- Recovery equipment (including refrigerant recovery containers) must be specifically designed to handle R410A.
- **Do not use an R-22 TXV.**
- Good Refrigeration practices require the installation of a field supplied liquid line drier, as shown in Fig.1.

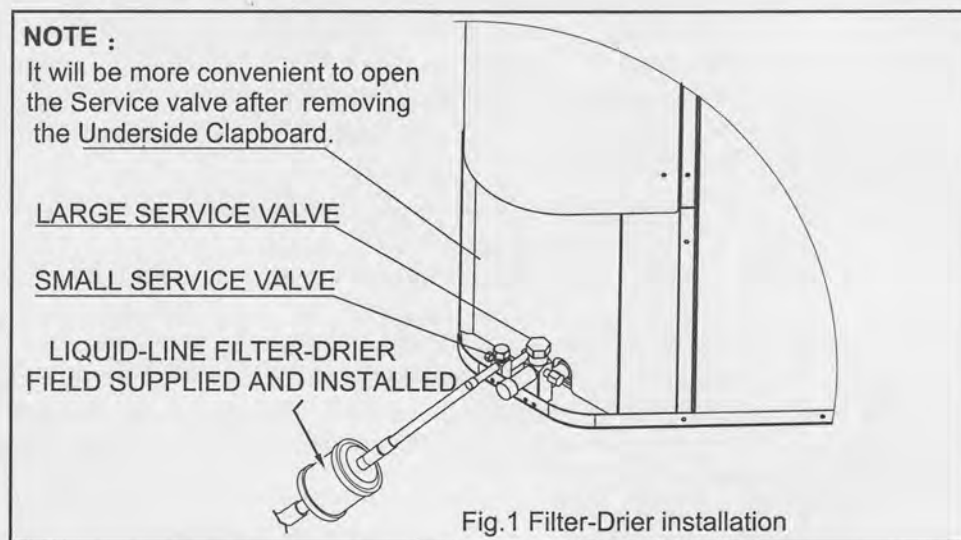

## 1.2 LIMITATIONS

The unit should be installed in accordance with all National, State, and Local Safety Codes and the limitations listed below:

- 1.Limitations for the indoor unit, coil and appropriate accessories must also be observed.
- 2.The outdoor unit must not be installed with any duct work in the air stream. The outdoor fan is the propeller type and is not designed to operate against any additional external static pressure.
- 3.The maximum and minimum conditions for operation must be observed to assure a system that will give maximum performance with minimum service.
- 4.This unit is not designed to operate with a low ambient kit. Do not modify the control system to operate with any kind of low ambient kit.
- 5.The maximum allowable line length for this product is 150 feet (Just for scroll compressor).

## 2.0 GENERAL

The outdoor units are designed to be connected to a matching indoor coil with braze connect lines. Units are factory charged with refrigerant for a matching indoor coil plus 15 feet of field supplied lines.

Matching indoor coils are available with a thermostatic expansion valve or an orifice for the most common usage. The orifice size and/or refrigerant charge may need to be changed for some indoor-outdoor unit combinations, elevation differences or total line lengths.

AIR DISCHARGE: ALLOW 60  
MINIMUM CLEARANCE.

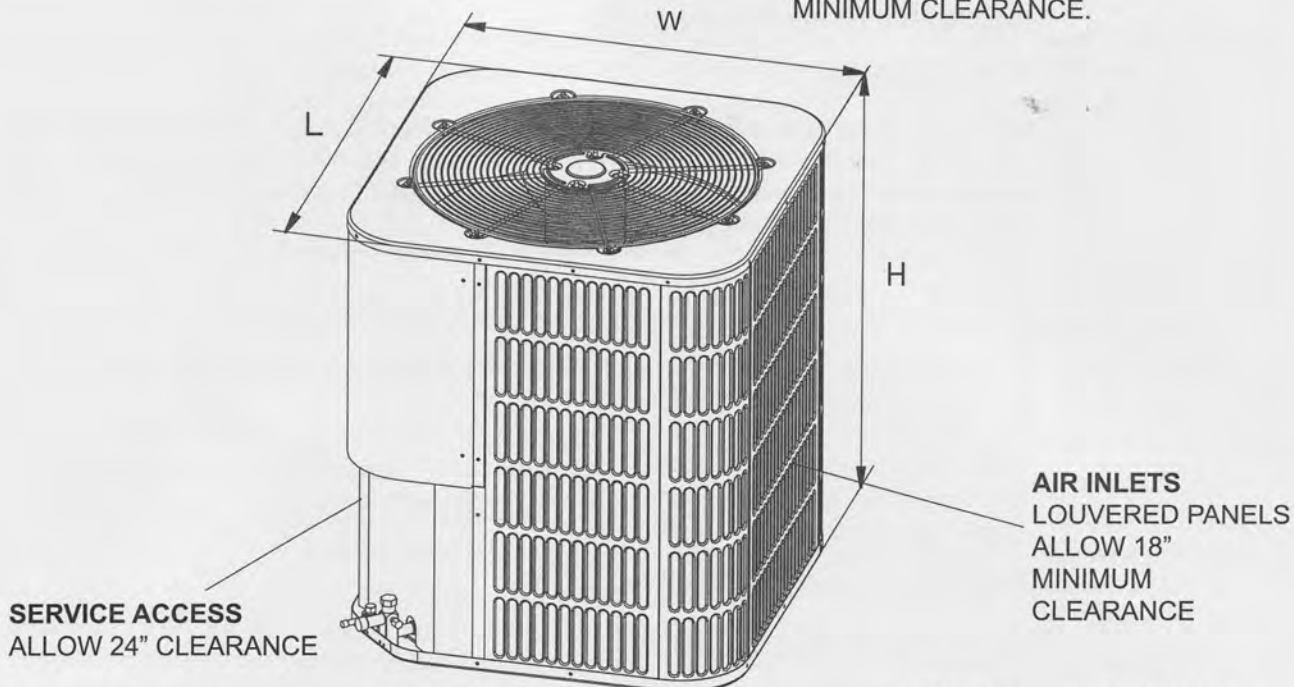

**NOTE:** GRILL APPEARANCE  
MAY VARY.

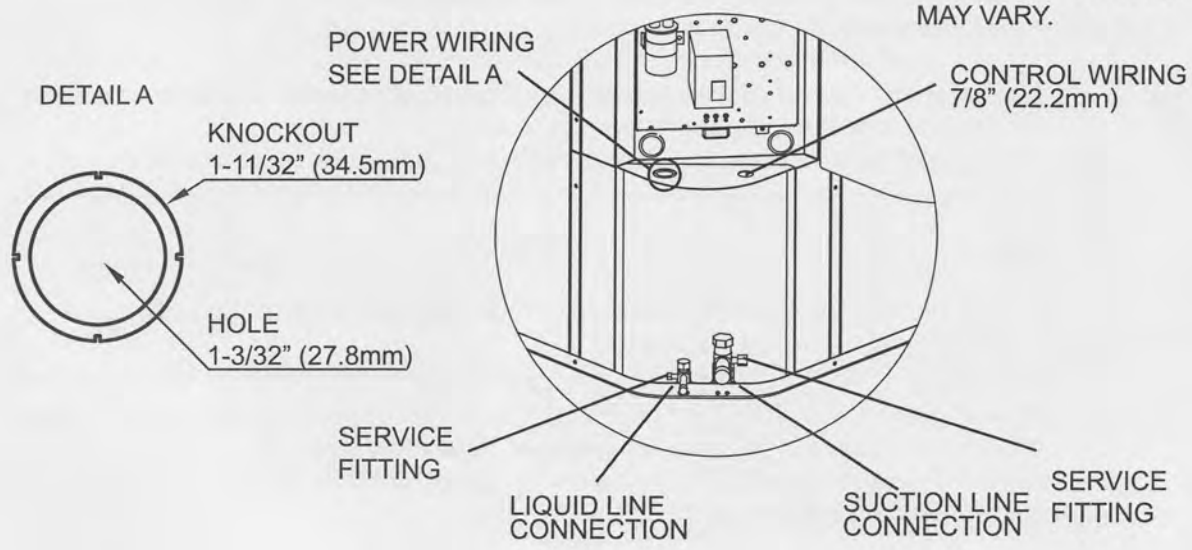

**DIMENSIONAL DATA**

**FIG.2 DIMENSIONS**

MODEL SIZE		Dimensions (Inches)			Refrigerant Connection Service Valve Size	
AC	HP	"H" in. [mm]	"W" in. [mm]	"L" in. [mm]	Liquid in.	Suction in.
18		24-15/16[633]	21-7/8[554]	21-7/8[554]	3/8	3/4
24	18/24	24-15/16[633]	23-5/8[600]	23-5/8[600]	3/8	3/4
30	30	24-15/16[633]	28[710]	28[710]	3/8	3/4
36	36	24-15/16[633]	29-1/8[740]	29-1/8[740]	3/8	3/4
	42	29-7/8[759]	28[710]	28[710]	3/8	3/4
42		33-3/16[843]	28[710]	28[710]	3/8	3/4
48	48	33-3/16[843]	28[710]	28[710]	3/8	7/8
60	60	33-3/16[843]	29-1/8[740]	29-1/8[740]	3/8	7/8

NOTES: 1. AC: Air Conditioner; HP: Heat Pump;

## 3.0 UNIT INSTALLATION

### 3.1 LOCATION

Before starting the installation, select and check the suitability of the location for both the indoor and outdoor unit. Observe all limitations and clearance requirements. The outdoor unit must have sufficient clearance for air entrance to the condenser coil, for air discharge and for service access. See Fig.2



#### NOTE

For multiple unit installations, units must be spaced a minimum of 36 inches apart. (Coil face to coil face.)

If the unit is to be installed on a hot sun exposed roof or a black-topped ground area, the unit should be raised sufficiently above the roof or ground to avoid taking the accumulated layer of hot air into the outdoor unit.

Provide an adequate structural support.

### 3.2 GROUND INSTALLATION

The unit may be installed at ground level on a solid base that will not shift or settle, causing strain on the refrigerant lines and possible leaks. Maintain the clearances shown in Fig.2 and install the unit in a level position.

Normal operating sound levels may be objectionable if the unit is placed directly under windows of certain rooms (bedrooms, study, etc.).

Top of unit discharge area must be unrestricted for at least 60 inches above the unit.



#### WARNING

The outdoor unit should not be installed in an area where mud or ice could cause personal injury or system damage.

Elevate the unit sufficiently to prevent any blockage of the air entrances by snow in areas where there will be snow accumulation. Check the local weather bureau for the expected snow accumulation in your area. Isolate the unit from rain gutters to avoid any possible wash out of the foundation.

### 3.3 ROOF INSTALLATION

When installing units on a roof, the structure must be capable of supporting the total weight of the unit, including a padded frame unit, rails, etc., which should be used to minimize the transmission of sound or vibration into the conditioned space.

### 3.4 UNIT PLACEMENT

1. Provide a base in the pre-determined location.
2. Remove the shipping carton and inspect for possible damage.
3. Compressor tie-down nuts should remain tightened.
4. Position the unit on the base provided.



#### CAUTION

This system uses R410A refrigerant which operates at higher pressure than R-22. No other refrigerant may be used in this system. Gauge sets, hoses, refrigerant containers, and recovery system must be designed to handle R410A. If you are unsure, consult the equipment manufacturer.

The outdoor unit must be connected to the indoor coil using field supplied refrigerant grade copper tubing that is internally clean and dry. Units should be installed only with the tubing sizes for approved system combinations. The refrigerant charge shown in the nameplate is for standard size interconnecting liquid line lengths up to 15 feet.



#### NOTE

Using a larger than specified line size could result in oil return problems. Using a too small line will result in loss of capacity and other problems caused by insufficient refrigerant flow. Slope horizontal suction lines at least 1" every 20 feet toward the outdoor unit to facilitate proper oil return.

### 3.5 UNIT MOUNTING

If elevating the heat pump, either on a flat roof or on a slab, observe the following guidelines.

1. The base pan provided elevates the heat pump 2" above the base pad.
2. If elevating a unit on a flat roof, use 4"× 4" (or equivalent) stringers positioned to distribute unit weight evenly and prevent noise and vibration (See Fig.3).

**NOTE: Do not block drain openings shown in Fig.3.**

3. If unit must be elevated because of anticipated snow fall, secure unit and elevating stand such that unit and/or stand will not tip over or fall off.

**NOTE: To tie down unit, see 3.6.**

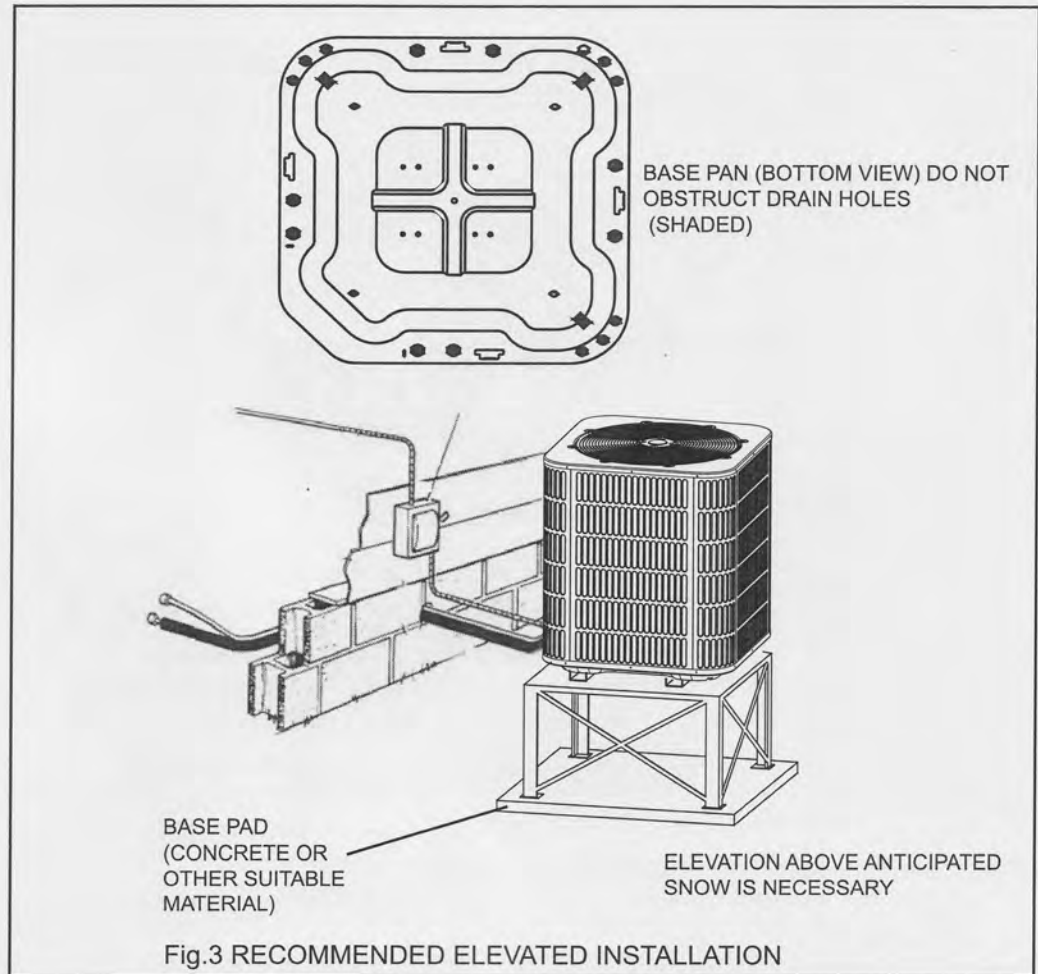

### 3.6 FACTORY-PREFERRED TIE-DOWN METHOD

Step 1: Prior to installing clear pad of debris.

**IMPORTANT**

Then cement pad must meet local codes and must be the proper thickness to accommodate fasteners.

Step 2: Center and level unit onto pad.

Step 3: Using field supplied L-shaped bracket to locate holes on concrete and drill pilot holes which is at least 1/4" deeper than fastener being used.

**IMPORTANT**

Self drilling screws to base pan should not exceed 3/8" long to avoid damaging coil.

Step 4: Using conventional practices to install brackets, tighten concrete fasteners and self-tapping screws (See Fig.4).

- NOTE:** 1. One bracket for each side. For extra stability, 2 brackets for each side.  
2. Do not over-tighten the concrete fastener to avoid weakening the concrete.

**IMPORTANT NOTE:**

These instructions are intended to provide a method to tie-down system to cement slab as a securing procedure for high wind areas. It is recommended to check Local Codes for tie-down methods and protocols.

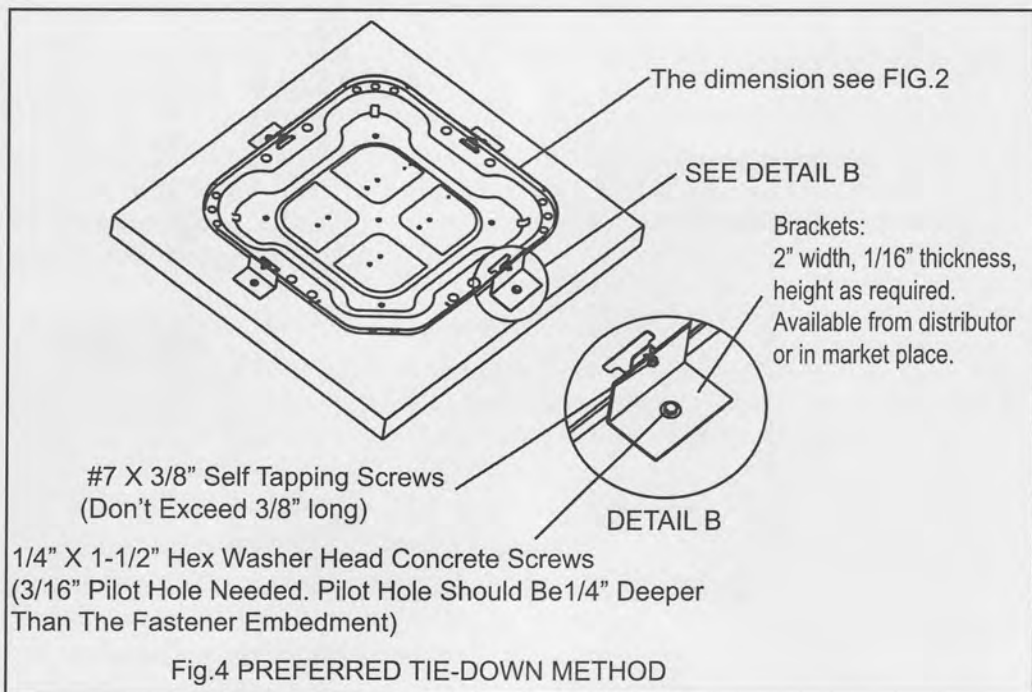



### 3.7 PRECAUTIONS DURING LINE INSTALLATION

1. Install the lines with as few bends as possible. Care must be taken not to damage the couplings or kink the tubing. Use clean hard drawn copper tubing where no appreciable amount of bending around obstruction is necessary, if soft copper must be used, care must be taken to avoid sharp bends which may cause a restriction.
2. The lines should be installed so that they will not obstruct service access to the coil, air handling system or filter.
3. Care must also be taken to isolate the refrigerant lines to minimize noise transmission from the equipment to the structure.
4. The suction line must be insulated. Tape and suspend the refrigerant lines as shown. DO NOT allow tube metal-to-metal contact. See Fig.5.
5. Use PVC piping as a conduit for all underground installations as shown in Fig.6. Buried lines should be kept as short as possible to minimize the build up of liquid refrigerant in the suction line during long periods of shutdown.
6. Pack a sealing material such as perma gum around refrigerant lines where they penetrate a wall to reduce vibration and to retain some flexibility.

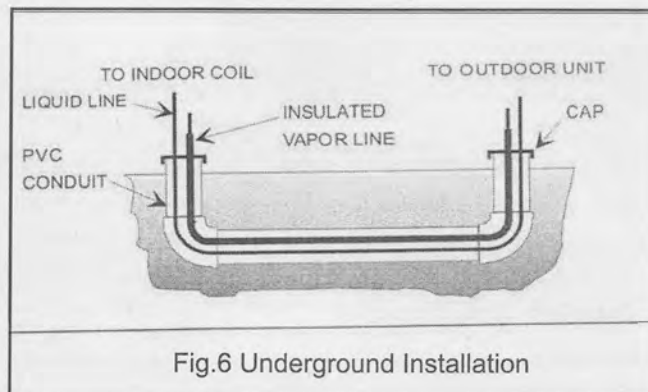
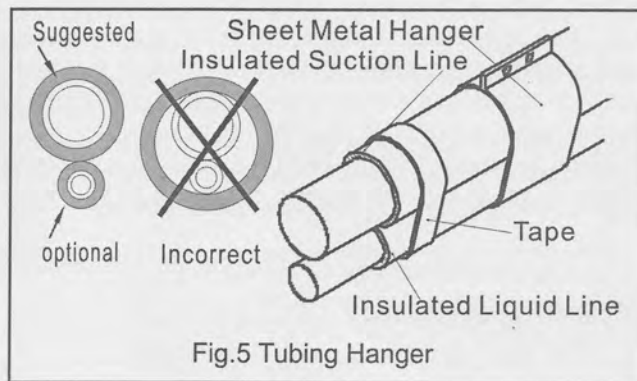

Connect the refrigerant lines using the following procedure:

1. Remove the cap and Schrader core from both the liquid and suction service valve service ports at the outdoor unit. Connect low pressure nitrogen to the liquid line service port.

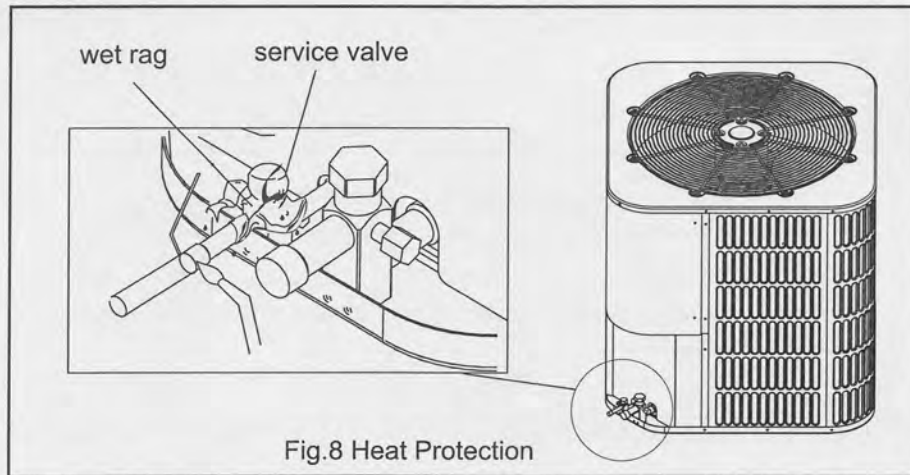

Fig.8 Heat Protection

2. Braze the liquid line to the liquid valve at the outdoor unit. Be sure to wrap the valve body with a wet rag. Allow the nitrogen to continue flowing. Refer to the Tabular Data Sheet for proper liquid line sizing.
3. Carefully remove the rubber plugs from the evaporator liquid and suction connections at the indoor coil.
4. Braze the liquid line to the evaporator liquid connection. Nitrogen should be flowing through the evaporator coil.
5. Slide the plastic cap away from the suction connection at the indoor coil. Braze the suction line to the evaporator suction connection. Refer to the Table 1 for proper suction line sizing.
6. Protect the suction valve with a wet rag and braze the suction line connection to the outdoor unit. The nitrogen flow should be exiting the system from the suction service port connection. After this connection has cooled, remove the nitrogen source from the liquid fitting service port.
7. Replace the Schrader core in the liquid and suction valves.
8. Leak test all refrigerant piping connections including the service port flare caps to be sure they are leak tight. **DO NOT OVER TIGHTEN (between 40 and 60 inch -lbs. maximum).**
9. Evacuate the suction line, evaporator, and the liquid line, to 350 microns or less.

Table 1: Recommended Liquid and Suction Tube Diameters (In.)

MODEL SIZE	LIQUID	SUCTION
	Tube Diameter	Tube Diameter
18	3/8	3/4
24	3/8	3/4
30	3/8	3/4
36	3/8	3/4
42	3/8	3/4
48	3/8	7/8
60	3/8	7/8

10. Replace cap on service ports. Do not remove the flare caps from the service ports except when necessary for servicing the system.
11. Release the refrigerant charge into the system. Open both the liquid and suction valves by removing the plunger cap and with an hex wrench back out counter-clockwise until valve stem just touches the chamfered retaining wall.
12. Replace plunger cap finger tight, then tighten an additional 1/12 turn (1/2 hex flat). Cap must be replaced to prevent leaks.



#### WARNING

Never attempt to repair any brazed connections while the system is under pressure. Personal injury could result.

See "System Charge" section for checking and recording system charge.

## 4.0 INTERCONNECTING TUBING

### 4.1 SUCTION AND LIQUID LINES

Keep all lines sealed until connection is made.

Make connections at the indoor coil first.

Refer to Line Size Information in Tables 2 and 3 for correct size and multipliers to be used to determine capacity for various suction line diameters and lengths of run. The losses due to the lines being exposed to outdoor conditions are not included.

The factory refrigerant charge in the outdoor unit is sufficient for 15 feet of standard size interconnecting liquid line. Calculate actual charge required with installed liquid line size and length as below.

5/16" ± .4 oz. per foot

3/8" ± .6 oz. per foot

1/2" ± 1.2 oz. per foot

### 4.2 MAXIMUM LENGTH OF LINES

The maximum length of interconnecting line is 150 feet (Just for scroll compressor).

Always use the shortest length possible with a minimum number of bends.

**NOTE:** Excessively long refrigerant lines cause loss of equipment capacity.

### 4.3 VERTICAL LIFT

Keep the vertical lift to a minimum. Use the following guidelines when installing the unit:

1. DO NOT exceed the vertical lift as indicated on Table 3.
2. It is recommended to use the smallest liquid line size permitted to minimize system charge which will maximize compressor reliability.
3. Table 3 may be used for sizing horizontal runs.

## 5.0 EVACUATION

It will be necessary to evacuate the system to 350 microns or less. If a leak is suspected, leak test with dry nitrogen to locate the leak. Repair the leak and test again. To verify that the system has no leaks, simply close the valve to the vacuum pump suction to isolate the pump and hold the system under vacuum. Watch the micron gauge for a few minutes. If the micron gauge indicates a steady and continuous rise, it's an indication of a leak. If the gauge shows a rise, then levels off after a few minutes and remains fairly constant, it's an indication that the system is leak free but still contains moisture and may require further evacuation if the reading is above 350 microns.

## LINE SIZING

TABLE 2: SUCTION LINE LENGTH/SIZE VS CAPACITY MULTIPLIER(R410A)

Model Size		1 1/2 Ton	2 Ton	2 1/2 Ton	3 Ton	3 1/2 Ton	4 Ton	5 Ton
Suction Line Connection Size		3/4" O.D.	3/4" O.D.	3/4" O.D.	3/4" O.D.	3/4" O.D.	7/8" O.D.	7/8" O.D.
Suction Line Run - Feet		5/8 Opt.	5/8 Opt.	5/8 Opt.	5/8 Opt.	5/8 Opt.	3/4 Opt.	1 1/8 Opt.
		3/4* Std.	3/4* Std.	3/4* Std.	3/4* Std.	3/4* Std.	7/8* Std.	7/8* Std.
25'	Optional	1.00	1.00	1.00	1.00	1.00	1.00	1.00
	Standard	1.00	1.00	1.00	1.00	1.00	1.00	0.99
50'	Optional	0.97	0.97	0.97	0.97	0.98	0.98	0.99
	Standard	0.98	0.98	0.98	0.99	0.98	0.98	0.98
100'	Optional	0.94	0.94	0.94	0.94	0.95	0.95	0.98
	Standard	0.95	0.95	0.96	0.97	0.97	0.97	0.94
150'	Optional	0.90	0.90	0.90	0.90	0.91	0.92	0.97
	Standard	0.92	0.92	0.93	0.96	0.96	0.96	0.90

NOTES:

\* Standard size

Using suction line larger than shown in chart will result in poor oil return and is not recommended.

TABLE 3 :LIQUID LINE SIZE (R410A)

Model Size	Line Size Connection Size (Inch O.D.)	Compressor Type	Line Size Connection And Line Size (Inch O.D.)	Liquid Line Size Outdoor unit above or below indoor coil					
				Total Equivalent Length - Feet					
				25	50	75	100	125	150
				Maximum Vertical Separation - Feet					
1 1/2 Ton	3/8"	Scroll	5/16	25	50	60	58	40	30
			3/8*	25	50	60	60	40	30
2 Ton	3/8"	Scroll	5/16	25	36	29	23	16	9
			3/8*	25	50	60	60	40	30
2 1/2 Ton	3/8"	Scroll	5/16	25	49	38	27	17	6
			3/8*	25	50	60	60	40	30
3 Ton	3/8"	Scroll	5/16	25	50	37	22	7	N/A
			3/8*	25	50	60	60	40	30
3 1/2 Ton	3/8"	Scroll	5/16	25	23	4	N/A	N/A	N/A
			3/8*	25	50	43	36	30	24
4 Ton	3/8"	Scroll	3/8*	25	46	38	30	22	15
			1/2	25	50	56	55	40	30
5 Ton	3/8"	Scroll	3/8*	25	50	56	44	32	20
			1/2	25	50	60	60	40	30

NOTES:

\* Standard line size

N/A Application not recommended.

## 6.0 ELECTRICAL CONNECTIONS

### 6.1 GENERAL INFORMATION & GROUNDING

Check the electrical supply to be sure that it meets the values specified on the unit nameplate and wiring label.

Power wiring, control (low voltage) wiring, disconnect switches and over current protection must be supplied by the installer. Wire size should be sized per requirements.



### CAUTION

All field wiring must USE COPPER CONDUCTORS ONLY and be in accordance with Local, National Fire, Safety & Electrical Codes. This unit must be grounded with a separate ground wire in accordance with the above codes.

The complete connection diagram and schematic wiring label is located on the inside surface of the unit service access panel and this instruction.

### 6.2 FIELD CONNECTIONS POWER WIRING

1. Install the proper size weatherproof disconnect switch outdoors and within sight of the unit.
2. Remove the screws at the side of the corner panel. Slide corner panel down and remove from unit. See Fig. 9.
3. Run power wiring from the disconnect switch to the unit.
4. Route wires from disconnect through power wiring opening provided and into the unit control box.
5. Install the proper size time-delay fuses or circuit breaker, and make the power supply connections.
6. Energize the crankcase heater if equipped to save time by preheating the compressor oil while the remaining installation is completed.

**NOTE:** When changing the motor, remove top cover first.

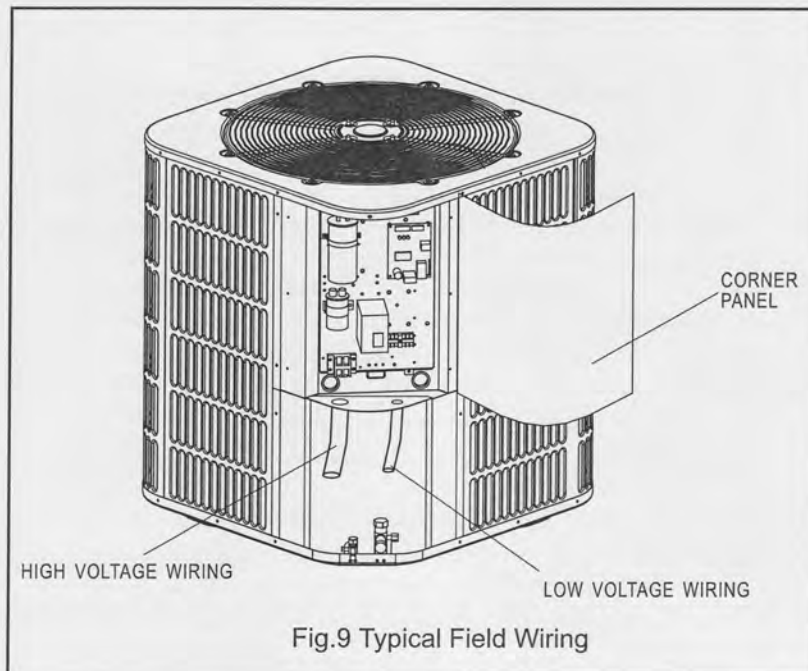

### 6.3 REMOVING THE TOP PANEL AND MOTOR

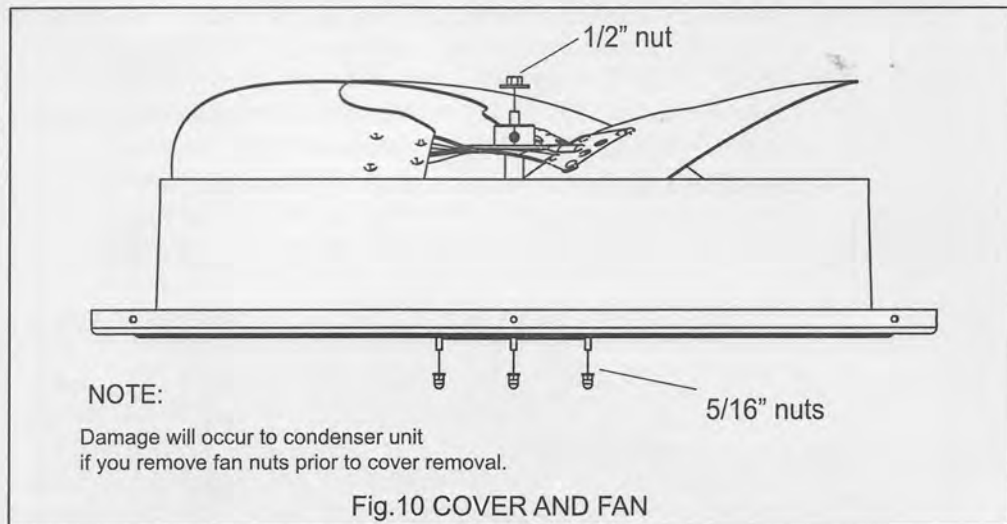

When motor requires changing follow the steps below:

Step 1: Go into electrical panel, disconnect motor power lines.

#### **IMPORTANT NOTE**

Disconnect main power to unit. Severe burns and electrical shock will occur if you do not disconnect main power.

Step 2: Remove cover (be careful of motor wires)

Step 3: Be sure to place fan cover unit on the ground as indicated in Fig. 10

#### **IMPROTANT NOTE**

Do not place or lean fan blades on ground or against surface.

Step 4: Remove fan motor by removing 5/16" nuts from cover.

Step 5: Remove fan blade from motor by removing 1/2" nut and place fan on the ground.

Step 6: Reverse removal process to reinstall the fan and motor.

#### **IMPROTANT NOTE**

When connecting motor wires be sure to check motor direction.

## 7.0 SYSTEM OPERATION

### 7.1 COMPRESSOR CRANKCASE HEATER (CCH) (Heat pump only,optional)

Refrigerant migration during the off cycle can result in a noisy start up. Add a crankcase heater to minimize refrigeration migration, and to help eliminate any start up noise or bearing "wash out".

All heaters must be located on the lower half of the compressor shell. Its purpose is to drive refrigerant from the compressor shell during long off cycles, thus preventing damage to the compressor during start-up.

At initial start-up or after extended shutdown periods, make sure the heater is energized for at least 12 hours before the compressor is started. (Disconnect switch on and wall thermostat off.)

#### ■ The crankcase heating start condition:

1.The crankcase heating start must meet two conditions:

A. Outdoor temperature <41° F.

B. Compressor stops working more than 3 hours.

2. Outdoor temperature <41° F and just connected to the power source.

#### ■ The crankcase heating stop must meet condition:

Outdoor temperature >44.6° F or compressor start.

### 7.2 REVERSING VALVE INTRODUCTION (Heat pump only)

Reversing valve energizes at the heating conditions, and cut off at the cooling condition.

### 7.3 PROTECTION FUNCTION INTRODUCTION (Heat pump only)

- **Sensor T3 (condenser pipe temperature) and T4 (outdoor ambient temperature)**  
 When open-circuit, compressor, outdoor fan motor and reverse valve will be OFF.  
 T3 > 143.6°F, compressor stop working ; T3 < 125.6°F, compressor start working.  
 When T4 < 5 °F, compressor will stop. If the electrical heater kit is installed in the indoor unit, the outdoor unit would provide a signal to drive up the heater.  
 When T4 > 10.4 °F, compressor will restart.
- **Discharge temperature protection (optional)**  
 When discharge temp. > 275 °F, the compressor will stop.  
 When discharge temp. < 194 °F, the compressor will restart.
- **High pressure protection (optional)**  
 When high pressure > 638 PSIG, the compressor and outdoor fan motor will stop.  
 When high pressure < 464 PSIG, the compressor and outdoor fan motor will restart (3 minutes delay necessary).
- **Low pressure protection**  
 Low pressure < 21 PSIG, the compressor and outdoor fan motor will stop.  
 Low pressure > 44 PSIG, the compressor and outdoor fan motor will restart (3 minutes delay necessary).  
 In stand-by status, the compressor will not start in low pressure protection.  
 Within 30 mins, if 4 protection cycles occurs. The system will be locked. It will be restore after power cycle.

### 7.4 DEFROST MODE INTRODUCTION (Heat pump only)

- **Manual defrost mode**  
 When the switch SW3-1 is set to "ON", the system turns to the defrost mode.  
 By the logic of **Shut-down conditions of defrost mode** to exit the defrost mode.  
 Caution: Once the manual defrost mode is finished, please switch the PCB switch back to "1".
- **Start-up conditions of defrost mode:**  
 When SW3-3 switch is set to "ON" (See in Fig 11), the mode will start up in any of the following conditions:
  1. Compressor operating, when T3 is < 30.2 °F last for 30 minutes;
  2. T3 is < 28.4 °F and compressor operating for the first time after connected to the power source.
  3. When T3 is < 28.4 °F and The system standby two hours continuously .

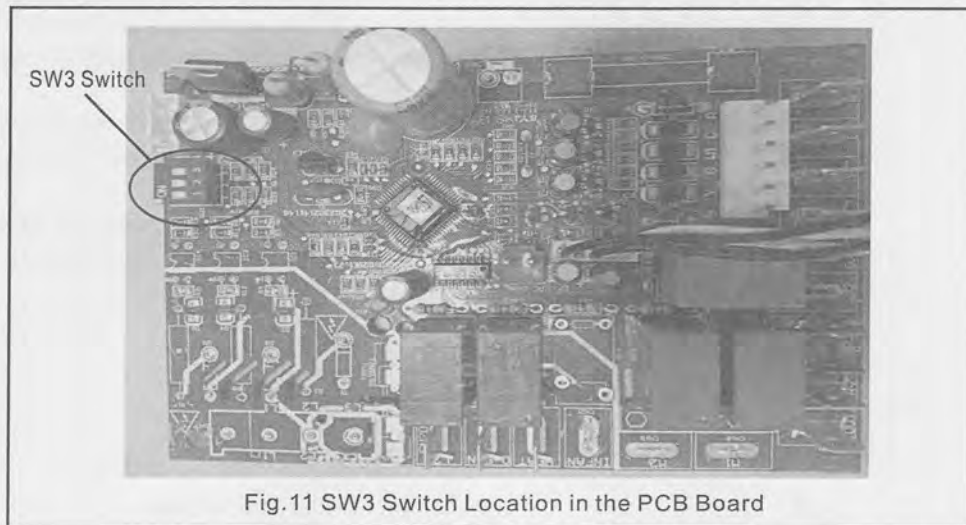

Fig.11 SW3 Switch Location in the PCB Board

	SW3-1	ON	MANUAL DEFROST
		OFF	AUTOMATIC DEFROST
	SW3-2	ON	RESERVED
		OFF	NORMAL DEFROST
	SW3-3	ON	DEFROSTING CYCLE: 30MIN
		OFF	DEFROSTING CYCLE: 60MIN

the following conditions:

1. Compressor operating, when T3 is < 30.2 °F last for 60 minutes;
2. T3 is < 28.4 °F and compressor operating for the first time after connected to the power source.
3. When T3 is < 28.4 °F and The system is on standby for two hours .

■ **Shut-down conditions of defrost mode:**

The mode will shut down in any of the following conditions:

1. The defrosted time lasting for 10 minutes;
2. T3 is ≥ 77 °F when T4 ≥ 28.4 °F;
3. Compressor stop operating;
4. T3 is ≥ 77 °F last for 60s when T4 < 28.4 °F.

## **8.0 CHECKING REFRIGERANT CHARGE**

Charge for all systems should be checked against the Charging Chart inside the access corner panel or Charging by weight.

**IMPORTANT:**Do not operate the compressor without charge in system. Addition of R-410A will raise pressures (suction, liquid and discharge).

### **8.1 CHARGING BY LIQUID PRESSURE**

In order to properly charge the system, the following conditions must be met:

- 1) Outdoor temperature above 60°F.
- 2) Indoor temperature between 70°F to 100°F.
- 3) Installation must be complete with brazed joints and drier visually inspected.
- 4) The unit electrical installation must be checked and unit powered for one (1) hour if crank case heater is used or five (5) minutes if no crankcase heater is used.

Follow these steps:

1. Run in cooling mode at least 10 minutes.
2. Measure OUTDOOR AMBIENT TEMPERATURE within 6 inches of coil.
3. Measure SUCTION LINE PRESSURE.
4. Find the TARGET LIQUID PRESSURE at the intersection between the SUCTION LINE PRESSURE and the OUTDOOR AMBIENT TEMPERATURE, if falls between rows or columns then estimate the TARGET LIQUID PRESSURE or SUCTION LINE PRESSURE falls between rows or columns then estimate the TARGET LIQUID PRESSURE between the rows and columns.
5. Compare the measured LIQUID LINE PRESSURE to the TARGET LIQUID PRESSURE, add charge to raise the pressure or recover charge to lower it.
6. After running unit for 10 minutes if the SUCTION LINE PRESSURE changes, go back to step 2 otherwise remove test equipment and cover the valves.

### **8.2 CHARGING BY WEIGHT**

For a new installation, evacuation of interconnecting tubing and indoor coil is adequate; otherwise, evacuate the entire system. The factory refrigerant charge in the outdoor unit is sufficient for 15 feet of standard size interconnecting liquid line. Calculate actual charge required with installed liquid line size and length, please see 4.1 of instruction.

With an accurate scale (+/- 1 oz.) adjust charge difference between that shown on the unit data plate and that calculated for the new system Installation. If the entire system has been evacuated, add the total calculated charge.

### **8.3 FINAL LEAK TESTING**

After the unit has been properly evacuated and charged, a halogen leak detector should be used to detect leaks in the system. All piping within the condensing unit, evaporator, and interconnecting tubing should be checked for leaks. If a leak is detected, the refrigerant should be recovered before repairing the leak. The Clean Air Act prohibits releasing refrigerant into the atmosphere.



## 9.0 WARRANTY

Assist owner with processing Warranty cards and/or online registration.

## 9.1 MAINTENANCE

1. Dirt should not be allowed to accumulate on the indoor or outdoor coils or other parts in the air circuit. Clean as often as necessary to keep the unit clean. Use a brush, vacuum cleaner attachment, or other suitable means.
2. The outdoor fan motor is permanently lubricated and does not require periodic oiling.
3. Refer to the furnace or air handler instructions for filter and blower motor maintenance.
4. The indoor coil and drain pan should be inspected and cleaned regularly to assure proper drainage.



### CAUTION

It is unlawful to knowingly vent, release or discharge refrigerant into the open air during repair, service, maintenance or the final disposal of this unit. When the system is functioning properly and the owner has been fully instructed, secure the owner's approval.

## 10.0 WIRING DIAGRAM



### CAUTION

These units must be wired and installed in accordance with all National and Local Safety Codes.

## 10.1 CONTROL WIRING FOR A/C UNITS

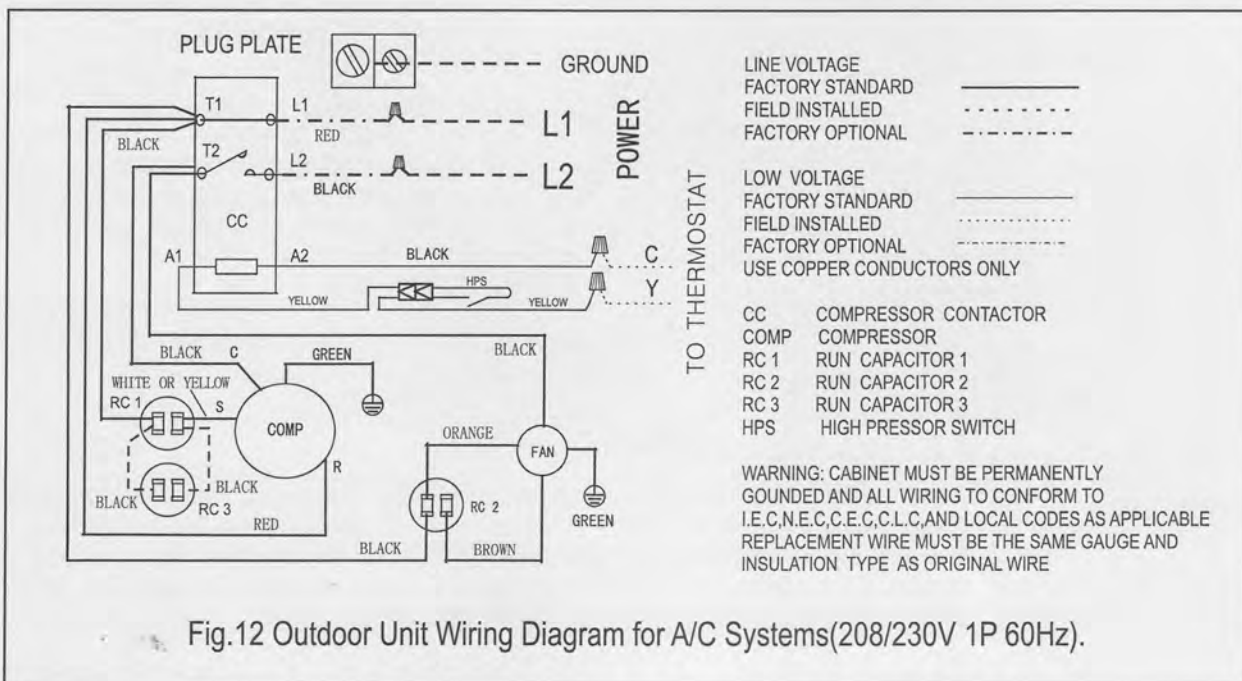
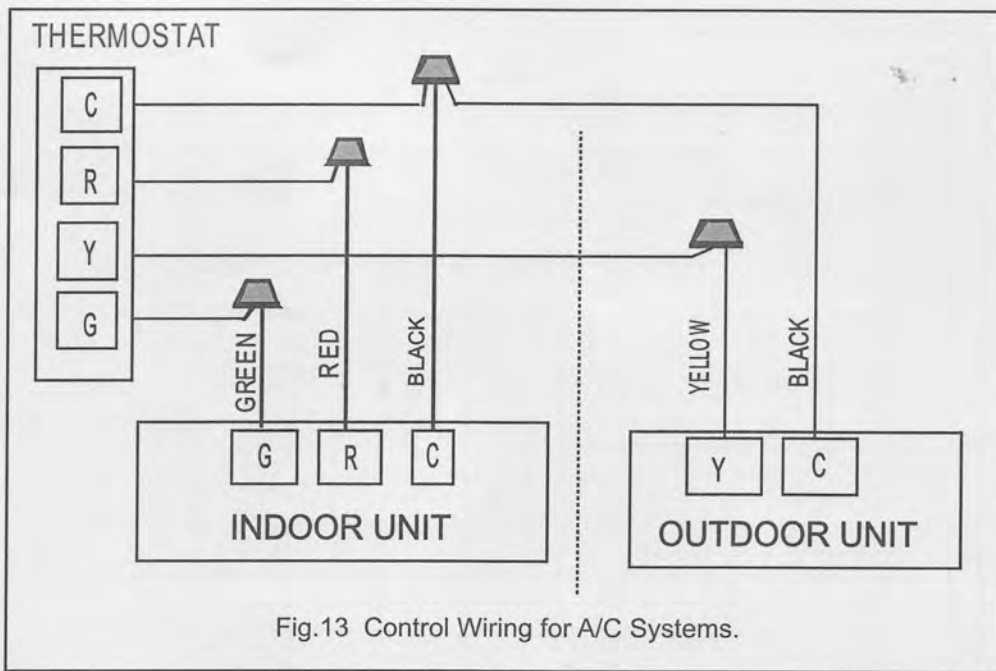
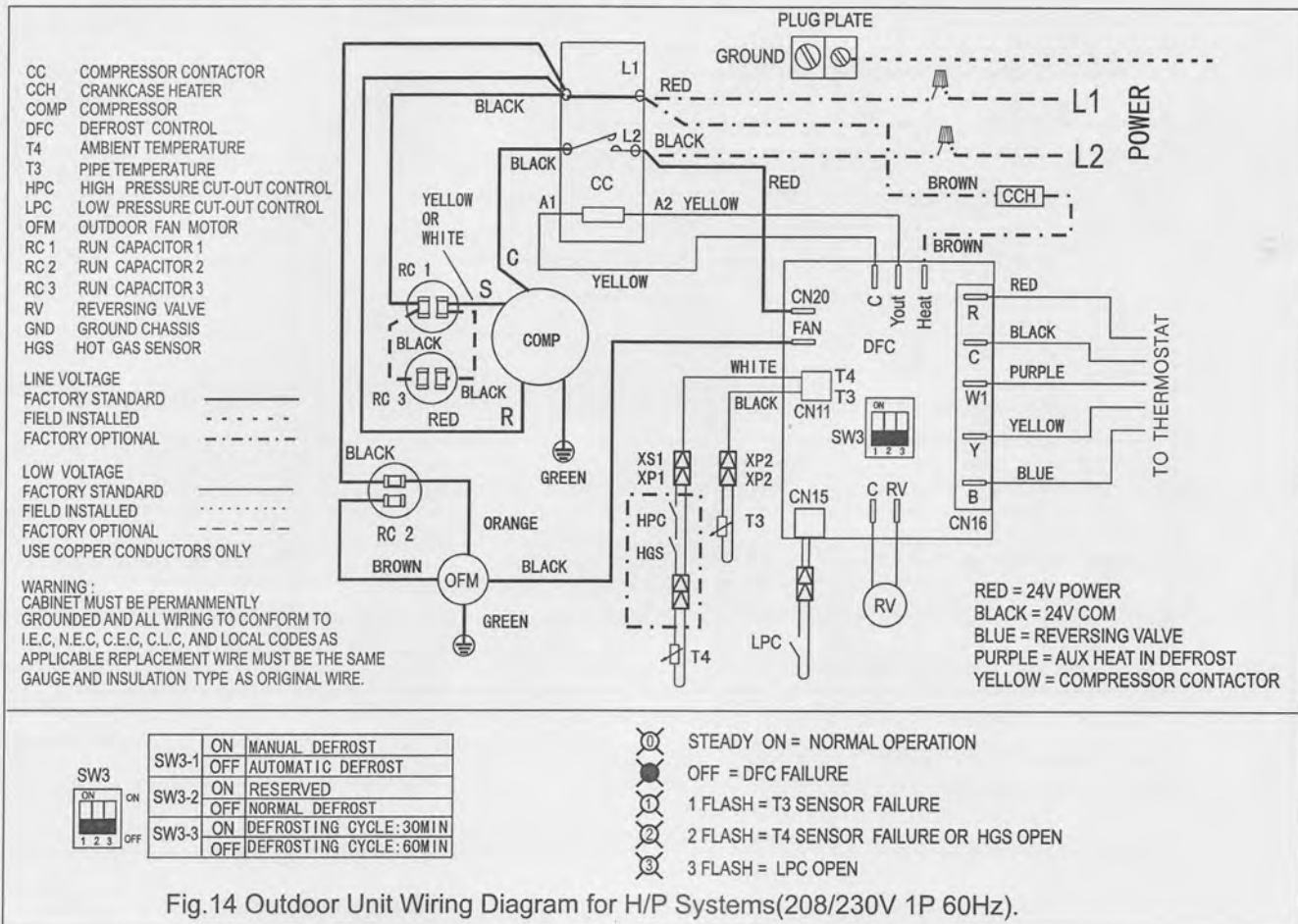
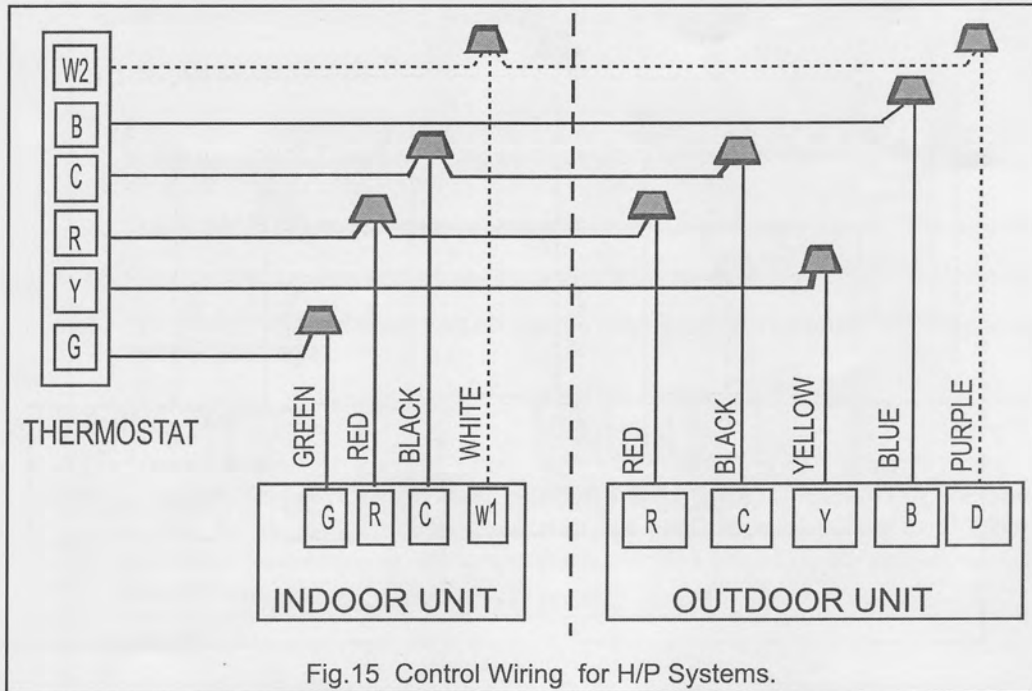

Fig.12 Outdoor Unit Wiring Diagram for A/C Systems(208/230V 1P 60Hz).



## 10.2 CONTROL WIRING FOR H/P UNITS





**TABLE 4: Electrical Data:**

Model	Minimum Circuit Ampacity(A)	Maximum Circuit Protector(A)	
AC	18	12.0	20
	24	17.6	30
	30	18.7	30
	36	21.9	35
	42	24.1	40
	48	29.0	50
	60	28.0	45
HP	18	11.9	20
	24	17.5	30
	30	18.7	30
	36	21.9	35
	42	24.1	40
	48	29.0	50
	60	34.7	60

**TABLE 5. Troubleshooting**

SYSTEM FAULTS	WHAT TO CHECK MODE																									
	HIGH VOLTAGE SUPPLY	COMPRESSOR CAPACITOR	O.D. FAN CAPACITOR	I.D. BLOWER CAPACITOR	CONTROL TRANSFORMER	LOW VOLTAGE WIRING	CONTRACTOR CONTACTS	STUCK COMPRESSOR	REF. UNDERCHARGE	INEFFICIENT COMP.	REF. OVERCHARGE	EXCESSIVE ETAP. LOAD	NONCONDENSABLES	RES. O.D. AIRFLOW	O.D. AIR RECIRCULATION	TXV STUCK OPEN	REF. CIR. RESTRICTIONS	RES. I.D. AIRFLOW	SOV LEAKING	CHECK VALVE DEFECTIVE	SOV COIL DEFECTIVE	LPC SENSOR DEF.	T4 TEMP. SENSOR DEF.	T3 TEMP. SENSOR DEF.	HC/HS SENSOR DEF.	
REFRIGERANT CIRCUIT																										
Head Pressure Too High	C																									
	H																									
Head Pressure Too Low	C																									
	H																									
Suction Pressure Too High	C																									
	H																									
Suction Pressure Too Low	C																									
	H																									
Liquid Refrig. Floodback (TXV)	C																									
	H																									
I.D. Coil Frosting	C																									
	H																									
Compressor Runs Inadequate or No Cooling/Heating	C																									
	H																									
ELECTRICAL																										
Compressor & O.D. Fan Won't Start	C	P	P																							
	H	P	P																							
Compressor Will Not Start But O.D. Fan Runs	C	P	P																							
	H	P	P																							
O.D. Fan Won't Start	C	P																								
	H	P																								
Compressor Hums But Won't Start	C																									
	H																									
I.D. Blower Won't Start	C	P	P	S																						
	H	P	P	S																						
DEFROST																										
Unit Won't Initiate Defrost	C																									
	H																									
Defrost Terminates on Time	C																									
	H																									
Unit Icing Up	C																									
	H																									

C- Cooling H - Heating P - Primary Causes S - Secondary Causes

**TABLE 6. Operational And Checkout Procedures**

Final phases of this installation are the unit Operational and Checkout Procedures. To obtain proper performance, all units must be operated and charge adjustments made in accordance with procedures found in the Service Facts of the Outdoor Unit.

After installation has been completed, it is recommended that the entire system be checked against the following list:

1. Be sure unit suspension(if used) is secure and that there are no tools or loose debris in or around or on top of the unit.....[ ]
2. Properly insulate suction lines and fittings. ....[ ]
3. Properly secure and isolate all refrigerant lines... [ ]
4. Verify that all electrical connections are tight. ....[ ]
5. Check all duct outlets; they must be open and unrestricted. [ ]
6. Check drain lines and be sure all joints are tight..... [ ]
7. Be sure that a return air filter is installed. .... [ ]
8. Operate complete system in each mode to verify proper performance. Verify operation of supplementary electric heater. ....[ ]