

# DYNOMATE<sup>®</sup>

## 4-BOLT CONNECTOR & DUCT WORK ACCESSORIES

A Division Of

**DURO  
DYNE<sup>®</sup>**



# PRODUCT CATALOG

& Duct Construction  
Standards

# Product Information



## Important Ordering Information

- All Dyn-O-Mate Flange, Corners & Cleats are manufactured with yellow label.
- Hollow Turning Vane, Vane Rail, Flat S, Flat Drive, & Standing S are manufactured with yellow label.
- All weights shown in this catalog are approximate.

## Product Gauge Identification

- All Flat Drive, Flat S, Flat Hanger Straps and Flange have painted ends to designate the metal gauge color coding is as follows:
  - 16 gauge: Yellow
  - 18 gauge: Black
  - 20 gauge: Blue
  - J Flange: Blue
  - 22 gauge: White
  - 24 gauge: Green
  - 26 gauge: Orange or Red
  - H Flange: White

## Warranty

- All Duro Dyne products are warranted against defects in quality or workmanship. Defective material will be repaired or replaced at the manufacturer's option. Liability resulting from defects in quality or workmanship is limited to the value of that material.

## Table of Contents

	Page #		Page #
<b>About Duro Dyne</b>	<b>3</b>	<b>Dyn-O-Mate Components</b>	<b>11</b>
<b>Access Doors</b>	<b>8</b>	<b>Flange</b>	<b>4</b>
<b>Assembly Instructions</b>	<b>12-13</b>	<b>Gasket</b>	<b>10</b>
<b>Cleats</b>	<b>5</b>	Butyl	10
<b>Corners</b>	<b>5</b>	Neoprene	10
<b>Duct Construction Standards</b>	<b>15-21</b>	<b>Nosing</b>	<b>6</b>
<b>1/2" W.G. Static</b>	<b>15</b>	<b>Product Information</b>	<b>2</b>
<b>1" W.G. Static</b>	<b>16</b>	Ordering Information	2
<b>2" W.G. Static</b>	<b>17</b>	Product Gauge Identification	2
<b>3" W.G. Static</b>	<b>18</b>	Warranty	2
<b>4" W.G. Static</b>	<b>19</b>	<b>Smacna Policy</b>	<b>14</b>
<b>6" W.G. Static</b>	<b>20</b>	<b>Test Results</b>	<b>22</b>
<b>10" W. G. Static</b>	<b>21</b>	<b>Tool &amp; Accessories</b>	<b>10</b>
<b>Ductwork Connections</b>	<b>7</b>	Crimper	10
Flat Drive	7	Cleat Tool	10
Flat S	7	Rod Lock	10
Standing S	7	<b>Vane and Rail</b>	<b>9</b>
<b>Duro Strap</b>	<b>6</b>		
Coiled Hanging Strap	6		
Flat Hanging Strap	6		

**All dimensions shown are approximate.**

## Contact Us

**DURO DYNE EAST**  
81 Spence St.  
Bay Shore, NY 11706  
Tel: (631) 249-9000  
Fax: (631) 249-8346  
Toll Free: 800-899-3876

**DURO DYNE MIDWEST**  
3825 Symmes Road  
Fairfield, OH 45011  
Tel: (513) 870-6000  
Fax: (513) 870-6005  
Toll Free: 800-966-6446

**DURO DYNE WEST**  
15005 Marquardt Ave.  
Santa Fe Springs, CA 90670  
Tel: (562) 926-1774  
Fax: (562) 926-5778  
Toll Free: 800-899-3963

**DURO DYNE CANADA**  
5030 Francois-Cusson  
Lachine, Quebec  
Canada H8T 1B3  
Tel: (514) 422-9760  
Fax: (514) 636-0328

**ABOUT DURO DYNE**

Established in 1952, Duro Dyne Corporation has evolved into the leading manufacturer of sheet metal accessories and equipment for the heating, ventilating, and air conditioning industry. Over the span of the last 50 years, Duro Dyne has expanded its plant locations and now employs over 200 people.

Duro Dyne's extensive research and development program has introduced more new products and processes than any other company in our field. Such things as Flexible Duct Connector, as we know it today, as well as Vane Rail and Blade Kits for multi-blade dampers were originally developed and patented by Duro Dyne Corporation. Other products that have now become standards in the sheet metal fabrication field were developed by Duro Dyne Corporation as well. In the fastening field Duro Dyne introduced the concept of self-drilling sheet metal screws. Quieturn Turning Vanes and Glasline Hardware for fiberglass duct systems all were originated by Duro Dyne.

Due to the increasing number of diverse items in our product line, Duro Dyne found it necessary to divide into the Duro Dyne Supply Division, DuroZone Division, Machinery Division, Duro Dyne Tool Division, Dyn-O-Mate and Dyna-Tite Divisions.

Our Supply Division continues to offer such familiar standards as Flexible Duct Connector, Insulation Fasteners, Screws and Rivets, Adhesives and Sealers, and Air Regulation Hardware. We continue to investigate new and innovative solutions for improving shop and field production. Our Spec-Seal Regulators and Side Glide Damper System parts are the latest innovations from this Division.

The DuroZone Division has made dramatic breakthroughs in Zone Control System designs. DuroZone provides cost effective and versatile methods of Zoning for residential and light commercial installation. DuroZone's staff of "in-house" engineers is continually researching the latest technological breakthroughs assuring the best products for today as well as tomorrow's markets.

Duro Dyne's Machinery Division is most noteworthy for the tremendous contribution in the field of insulation fastening...from the first hand held Pinspotter to the FGMH Auto Shift Multi-Head Pinspotter System used by some of the largest contracting shops in the world today. In addition to the finest Pinspotting equipment, Duro Dyne's Machinery Division continues to manufacture the finest Insulation Cutting Equipment, Portable Spotwelders, Water Based Adhesive Application System and Turning Vane Fabricating Equipment. Quality and workmanship have always been of prime importance for the manufacture of our equipment.

The Duro Dyne Tool Division markets the finest quality hand tools for the sheet metal tradesman. In addition to such tools as snips, notchers, crimpers, and seamers, Duro Dyne stocks a full complement of other tools specifically designed for the HVAC industry. Duro Dyne is constantly testing and evaluating new tools for possible addition into our already extensive hand tool line.

Duro Dyne's marketing expertise and Dyn-O-Mate's engineered designs combine to bring the finest 4-bolt duct connection system to the market. In the same vein, our Dyna-Tite Division brings the HVAC Industry an innovative hanging system that eliminates the costly need for threaded rod.

Duro Dyne Corporation does not stop here, for we continue to probe areas in which we could be of greater service. We trust that you will call on us if you have any suggestions as to how we may serve you better.

DURO DYNE CORPORATION



Randall S. Hinden, President



# Flange

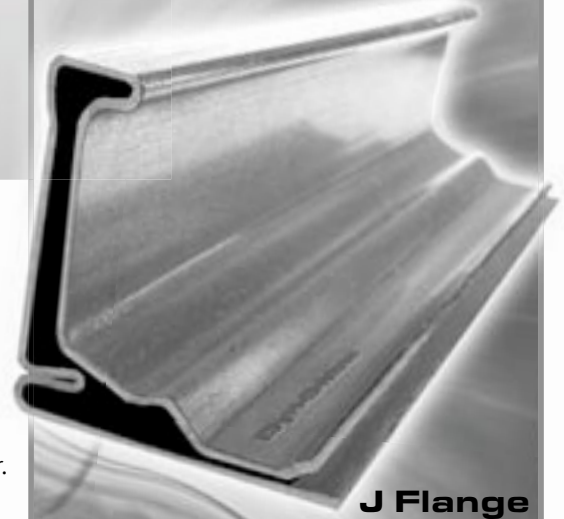
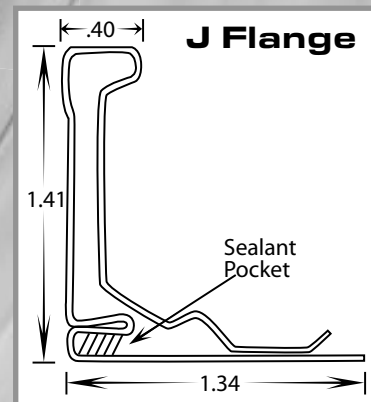

## DYN-O-MATE FLANGES

### DOMJ Flange

- Designed to strengthen the duct wall and connect duct sections together.
- Furnished with an integrated sealant pocket for a secure air tight fit.
- Manufactured from 20-gauge steel in both 12ft. & 20ft. lengths.
- DOMJ is designed for large commercial and high-pressure applications.
- Available in Aluminum & Stainless Steel.
- Bundles of 20ft. lengths available only with a Full Truckload order.

### DOMH Flange

- Designed to strengthen the duct wall and connect duct sections together.
- Furnished with an integrated sealant pocket for a secure air tight fit.
- Manufactured from 22-gauge steel in both 12ft. & 20ft. lengths.
- DOMH is designed for low to medium pressure or residential applications.
- Bundles of 20ft. lengths available only with a Full Truckload.

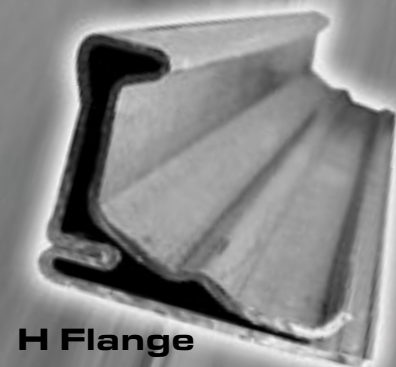
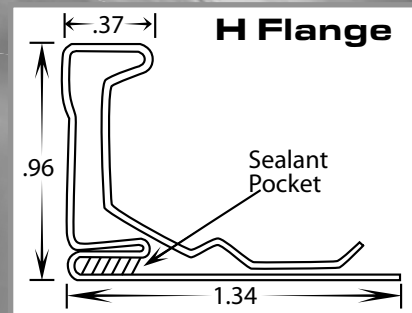

### Ordering Information

Item #	Code	Description	Packaging	Weight (lbs.)
21230	DOMJ20	J Flange -20ft.	1000ft./Bundle	740
21231	DOMH20	H Flange-20ft.	1000ft./Bundle	530
21234	DOMJ12	J Flange-12ft.	1200ft./Bundle	890
21235	DOMH12	H Flange -12ft.	1200ft./Bundle	640

# Corners & Cleats

## DYN-O-MATE CORNERS

- DDJ corners are manufactured from 11-gauge steel. For use with DOMJ Flange.
- DDH corners are manufactured from 12-gauge steel. For use with DOMH Flange.
- DOMC and DOMF corners are manufactured from 16-gauge steel.
- DDCS (TDC) & DDFS (TDF) corners are for use in corner insertion machines and are manufactured from 16-gauge steel.
- DDJ, DDH, TDC, & TDF corners are available in Aluminum & Stainless Steel.
- Nuts and Bolts are also sold separately. (See page 10)

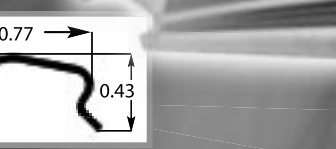
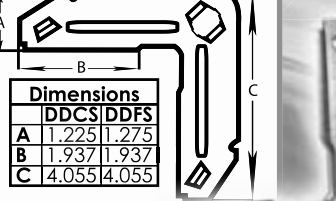
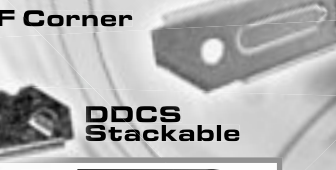
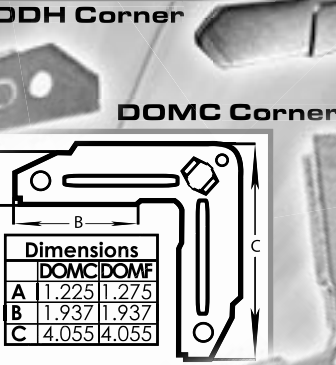
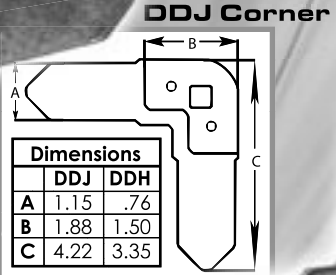
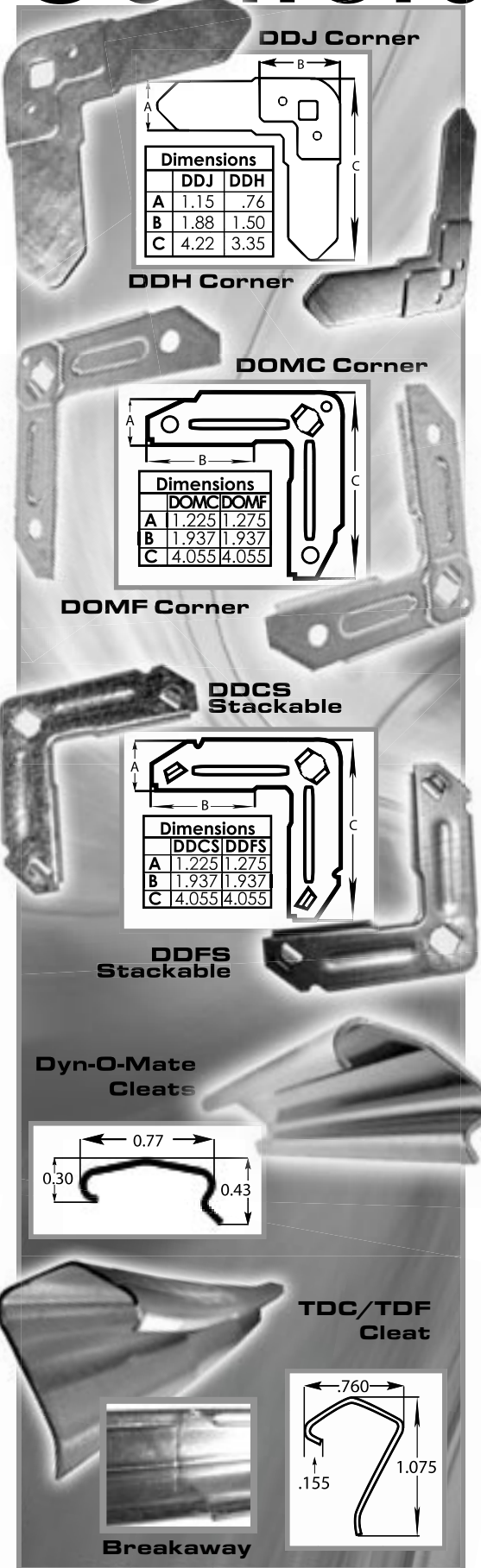

**Breakaway**

### Ordering Information

Item #	Code	Description	Packaging	Weight (lbs.)
21240	DDJ	Corner for DOMJ Flange	250/Box	75
21241	DDH	Corner for DOMH Flange	250/Box	38
21242	DDJNB	J Corner with 3/8 in. Nut & Bolt	250/Box	83
21249	DDHNB	H Corner with 1/2 in. Nut & Bolt	250/Box	41
21254	DOMC	TDC Corner	250/Box	46
21255	DOMF	TDF Corner	250/Box	46
21245	DDCS	TDC Stackable Corner	250/Box	35
21246	DDFS	TDF Stackable Corner	250/Box	35

## DYN-O-MATE Cleats

- DOM-CLT and DOM-PCLT for use with DOMJ & DOMH 20 gauge flanges for airtight duct connections.
- DOM-CLT and TDF-CLT are manufactured from 20 gauge galvanized steel 6" pieces.
- DOM-PCLT AND TDF-PCLT are extruded .070" PVC and designed for breakaway connection needs.
- TDF-CLT is used with TDF connection.
- TDC-CLT is used with TDC connection.
- TDC-2230 is 22 gauge steel formed into lengths of 30" long and divided into five 6" cleats that are partially cut through allowing them to be easily separated into 6" pieces.
- TDF-CLT is also available in pre-scored lengths of 30".

### Dyn-O-Mate CLEATS Ordering Information

Item #	Code	Description	Packaging	Weight (lbs.)
21250	DOM-CLT	6in. Metal	500/Box (250ft.)	40
21252	DOM-PCLT	6in. Plastic	500/Box (250ft.)	10

### TDC/TDF CLEATS Ordering Information

Item #	Code	Description	Packaging	Weight (lbs.)
13230	TDC-2230	6in. TDC (Pre-Scored Cleat)	60-30in. pcs. (150ft.)	33
21251	TDF-CLT	TDF 6in. Metal	500/Box (250ft.)	40
21253	TDF-PCLT	TDF 6in. Plastic	500/Box (250ft.)	10
21257	TDC-CLT	TDC 6 in. Metal	500/Box (250ft.)	55

# Nosing & Hanging Strap

## DYN-O-MATE NOSING

- Protects exposed edge of the duct liner
- Minimizes the possibility of liner delaminating and causing blockage in the ductwork.
- Manufactured from 26-gauge galvanized steel.
- Designed with self adhesive tape for easy installation.
- Available in 1/2", 1", 1 1/2", and 2" height. 10ft. Lengths

### Ordering Information

Item #	Code	Description	Packaging	Weight (lbs.)
21260	NOS012	1/2 in. Nosing-10ft.	1000ft./Bundle	13
21261	NOS100	1 in. Nosing-10ft.	1000ft./Bundle	16
21262	NOS112	1-1/2 in. Nosing-10ft.	1000ft./Bundle	19
21263	NOS200	2 in. Nosing-10ft.	1000ft./Bundle	23

## COILED & FLAT GALVANIZED DURO STRAP

- Versatile product used for hanging ductwork.
- Manufactured from 16, 18, 22, and 24 gauge steel.
- Coiled straps make it convenient to carry and easy to cut without wasting material.
- Flat Hanger Strap pre-cut 10ft. lengths.

### COILED DURO STRAP

#### Ordering Information

Item #	Code	Description	Packaging	Weight (lbs.)
13249	PGS	24 ga. Perforated Galvanized Strap-3/4 in.	100ft./Box	4
13250	GS16	16ga. Galvanized Duro Strap-1in.	200ft./Box	44
13251	GS18	18ga. Galvanized Duro Strap-1in.	200ft./Box	36
13252	GS22	22ga. Galvanized Duro Strap-1in.	200ft./Box	24
13253	GS24	24ga. Galvanized Duro Strap-1in.	200ft./Box	20
13254	GS26	26ga. Galvanized Duro Strap-1in.	200ft./Box	20

### FLAT 10FT. HANGING STRAP

#### Ordering Information

Item #	Code	Description	Packaging	Weight (lbs.)
13270	HS1610	16ga. Galvanized Hanging Strap-1in.	10-10ft. pcs./Bundle	22
13271	HS1810	18ga. Galvanized Hanging Strap-1in.	10-10ft. pcs./Bundle	18
13272	HS2210	22ga. Galvanized Hanging Strap-1in.	10-10ft. pcs./Bundle	12
13273	HS2410	24ga. Galvanized Duro Strap-1in.	10-10ft. pcs./Bundle	10

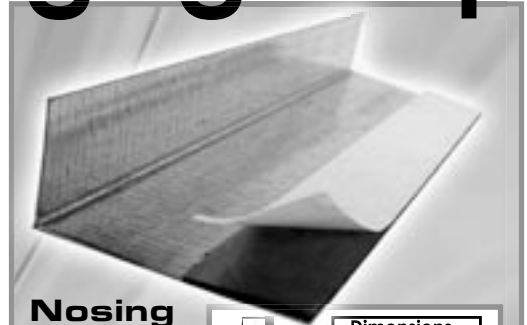

**Nosing**

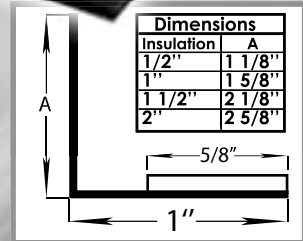

**Perforated Galvanized Strap**



**Coiled Duro Strap**

**Flat Hanging Strap**

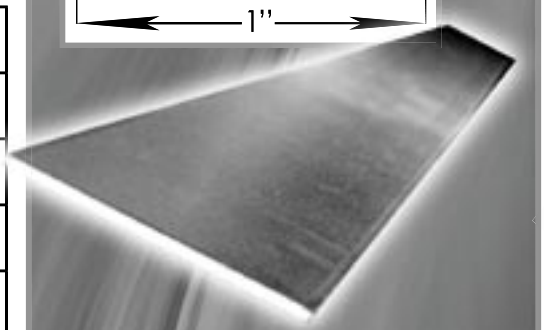
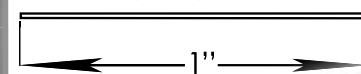



# Flat Drive, Flat S & Standing S

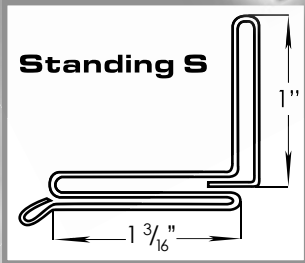
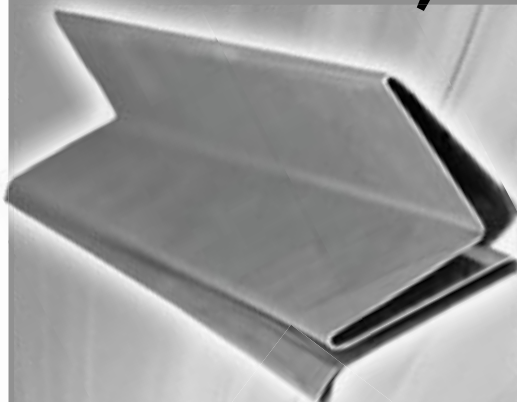

## STANDING S LOCK

- Designed to reinforce the connection on the wider ductwork applications.
- Manufactured with 22, 24 or 26 gauge steel, available in 1" widths. (26 gauge is available in both 1" and 1/2")
- Available in 10ft. lengths.

### Ordering Information

Item #	Code	Description	Packaging	Weight (lbs.)
13235	SS-2210	22ga. 1in. Standing S 10ft.	10-10ft. pcs./Bundle	69
13214	SS-2410	24ga. 1in. Standing S 10ft.	10-10ft. pcs./Bundle	48
13215	SS-2610	26ga. 1in. Standing S 10ft.	10-10ft. pcs./Bundle	39
13228	SS12-2610	26ga. 1/2in. Standing S 10ft.	10-10ft. pcs./Bundle	20

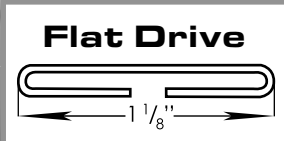

## FLAT DRIVE CLEAT

- Designed to secure the connection for lighter ductwork applications.
- Manufactured from 24 and 26 gauge galvanized steel.
- Perfect for lighter gauge and residential ductwork applications
- Tapered ends for an easy start.
- Available in 5ft. or 10ft. lengths.

### Ordering Information

Item #	Code	Description	Packaging	Weight (lbs.)
13255	FD-2410	24ga. Flat Drive 10ft.	10-10ft. pcs./Bundle	17
13257	FD-2610	26ga. Flat Drive 10ft.	10-10ft. pcs./Bundle	14
13218	FD-2605	26ga. Flat Drive 5ft.	10-5ft. pcs./Bundle	34

## FLAT S LOCK

- Designed to secure the connection for lighter ductwork applications.
- Manufactured from 24 and 26 gauge galvanized steel.
- Available in 5ft. or 10ft. lengths.

### Ordering Information

Item #	Code	Description	Packaging	Weight (lbs.)
13256	FS-2410	24ga. Flat S Lock 10ft.	10-10ft. pcs./Bundle	30
13258	FS-2610	26ga. Flat S Lock 10ft.	10-10ft. pcs./Bundle	24
13219	FS-2605	26ga. Flat S Lock 5ft.	10-5ft. pcs./Bundle	60



# Access Doors

88 ACCESS DOORS

## DYN-O-MATE FLAT INSULATED ACCESS DOORS

(For Rectangular Duct)				
ITEM #	CODE	DESCRIPTION	PACKAGING	WEIGHT (LBS.)
21177	MFADI48	4X8 FLAT Insulated Access Door	10 Pcs./Box	12
21178	MFADI812	8X12 FLAT Insulated Access Door	10 Pcs./Box	35
21179	MFADI1216	12X16 FLAT Insulated Access Door	5 Pcs./Box	29
*High Temperature & other sizes available upon request.				

## DYN-O-MATE INSULATED ACCESS DOORS

4 x 8 Round Access Doors (For Round Duct)				
ITEM #	CODE	DESCRIPTION	PACKAGING	WEIGHT (LBS.)
21135	MRADI48-7	4X8-7RD Insulated Access Door	10 Pcs./Box	12
21137	MRADI48-11	4X8-11RD Insulated Access Door	10 Pcs./Box	12
21138	MRADI48-14	4X8-14RD Insulated Access Door	10 Pcs./Box	12

8 x 12 Round Access Doors (For Round Duct)				
ITEM #	CODE	DESCRIPTION	PACKAGING	WEIGHT (LBS.)
21144	MRADI812-14	8X12-14RD Insulated Access Door	10 Pcs./Box	35
21146	MRADI812-18	8X12-18RD Insulated Access Door	10 Pcs./Box	35
21148	MRADI812-22	8X12-22RD Insulated Access Door	10 Pcs./Box	35

12 x 16 Round Access Doors (For Round Duct)				
ITEM #	CODE	DESCRIPTION	PACKAGING	WEIGHT (LBS.)
21151	MRADI216-18	12X16-18RD Insulated Access Door	5 Pcs./Box	29
21154	MRADI216-24	12X16-24RD Insulated Access Door	5 Pcs./Box	29

## DYN-O-MATE UNINSULATED ACCESS DOORS

4 X 8 ROUND ACCESS DOORS (For Round Duct)				
ITEM #	CODE	DESCRIPTION	PACKAGING	WEIGHT (LBS.)
21101	MRADU48-7	4X8-7RD UN-IAD	10 Pcs./Box	12
21103	MRADU48-11	4X8-11RD UN-IAD	10 Pcs./Box	12
21104	MRADU48-14	4X8-14RD UN-IAD	10 Pcs./Box	12

8 X 12 ROUND ACCESS DOORS (For Round Duct)				
ITEM #	CODE	DESCRIPTION	PACKAGING	WEIGHT (LBS.)
21110	MRADU812-14	8X12-14RD UN-IAD	10 Pcs./Box	35
21112	MRADU812-18	8X12-18RD UN-IAD	10 Pcs./Box	35
21114	MRADU812-22	8X12-22RD UN-IAD	10 Pcs./Box	35

12 X 16 ROUND ACCESS DOORS (For Round Duct)				
ITEM #	CODE	DESCRIPTION	PACKAGING	WEIGHT (LBS.)
21117	MRADU1216-18	12X16-18RD UN-IAD	5 Pcs./Box	29
21120	MRADU1216-24	12X16-24RD UN-IAD	5 Pcs./Box	29

## DYN-O-MATE FLAT UNINSULATED ACCESS DOORS

(For Rectangular Duct)				
ITEM #	CODE	DESCRIPTION	PACKAGING	WEIGHT (LBS.)
21170	MFADU48	4X8 FLAT UN-IAD	10 Pcs./Box	12
21171	MFADU812	8X12 FLAT UN-IAD	10 Pcs./Box	35
21172	MFADU1216	12X16 FLAT UN-IAD	5 Pcs./Box	29

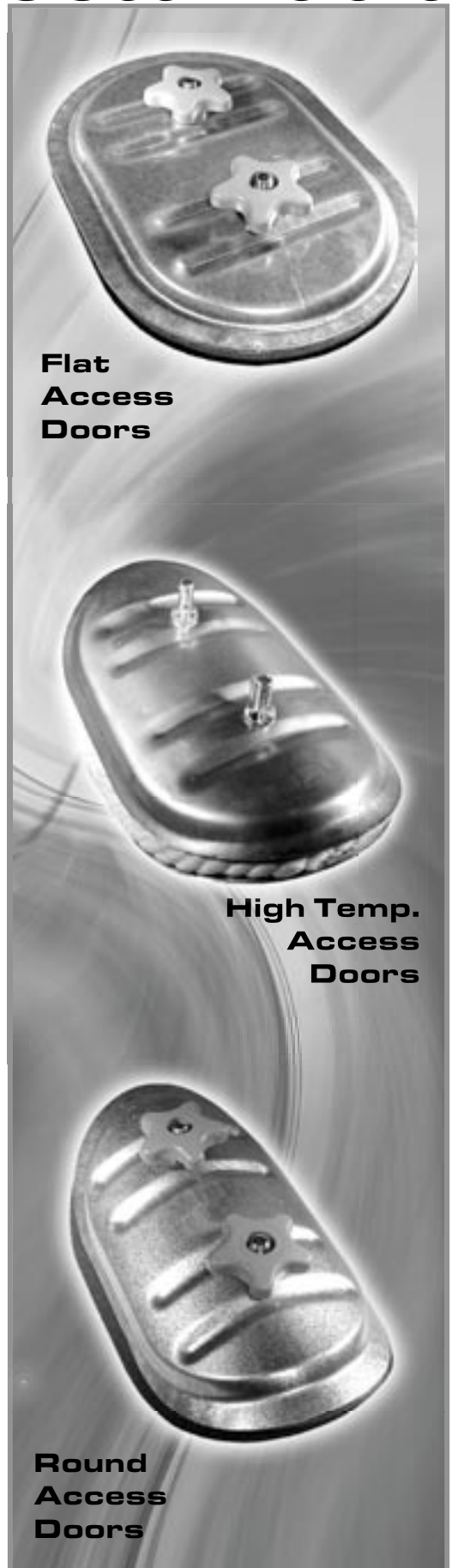

**Flat Access Doors**

**High Temp. Access Doors**

**Round Access Doors**

DYN-O-MATE



# Vane and Rail



2" Vane & Rail

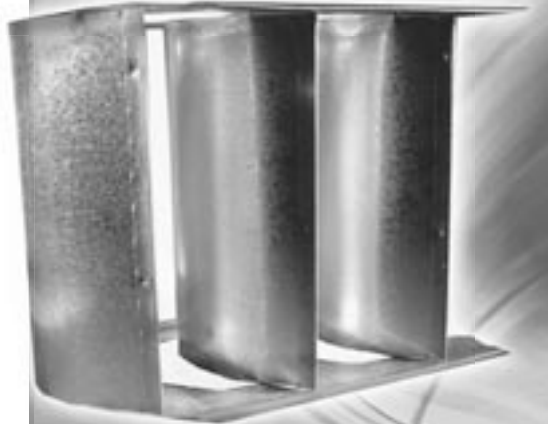

4" Vane & Rail

- Hollow Turning Vane and Vane Rail are designed to redirect the air through elbows and tees in the ductwork without significant loss of air pressure. Assembled Vane & Rail minimizes turbulence in the ductwork
- The Vane Rail has self aligning tabs for easy vane installation.
- 2in. Turning Vane are manufactured from 26-gauge galvanized steel.
- 4in. Turning Vane are manufactured from 24-gauge galvanized steel.
- 2in. and 4in. Vane Rail are manufactured from 22-gauge galvanized steel.

## HOLLOW TURNING VANE

Ordering Information					
Item #	Code	Description	Packaging	Weight (lbs.)	Master Skid Qty.
13203	HTV2-2610	26ga. 2in. Turning Vane 10ft.	10-10ft. pcs./Bundle	45	7200ft.
13220	HTV2-10AL	Alum. 2in. Turning Vane 10ft.	10-10ft. pcs./Bundle	26	7200ft.
13224	HTV2-10SS	Stainless 2in. Turning Vane 10ft.	10-10ft. pcs./Bundle	47	7200ft.
13207	HTV4-2410	24ga. 4in. Turning Vane 10ft.	5-10ft. pcs./Bundle	55	2500ft.
13222	HTV4-10AL	Alum. 4in. Turning Vane 10ft.	5-10ft. pcs./Bundle	33	2500ft.
13226	HTV4-10SS	Stainless 4in. Turning Vane 10ft.	5-10ft. pcs./Bundle	58	2500ft.

## VANE RAIL

Ordering Information					
Item #	Code	Description	Packaging	Weight (lbs.)	Master Skid Qty.
13204	HVR2-2210	22ga. 2in. Vane Rail 10ft.	10-10ft. pcs./Bundle	46	6000ft.
13221	HVR2-10AL	Alum. 2in. Vane Rail 10ft.	10-10ft. pcs./Bundle	18	6000ft.
13225	HVR2-10SS	Stainless 2in. Vane Rail 10ft.	10-10ft. pcs./Bundle	30	6000ft.
13208	HVR4-2210	22ga. 4in. Vane Rail 10ft.	10-10ft. pcs./Bundle	71	2000ft.
13223	HVR4-10AL	Alum. 4in. Vane Rail 10ft.	10-10ft. pcs./Bundle	36	2000ft.
13227	HVR4-10SS	Stainless 4in. Vane Rail 10ft.	10-10ft. pcs./Bundle	59	2000ft.

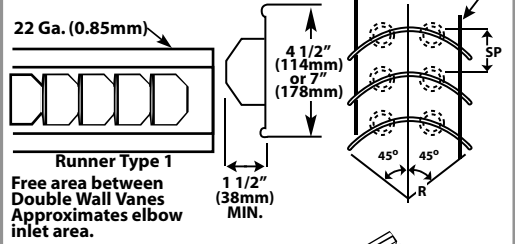
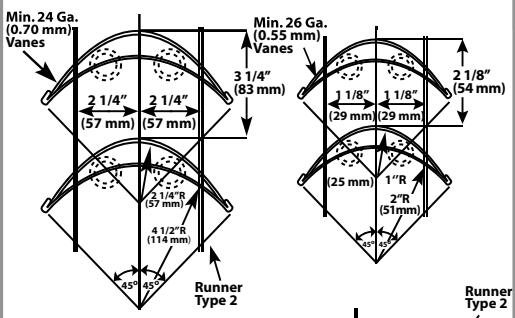

Single Vane Schedule			
	R	SP	GA
Small	2" (51mm)	1 1/2" (38mm)	24 (0.70mm)
Large	4 1/2" (114mm)	3 1/4" (83mm)	22 (0.85mm)

See notes on fig.2-4. Other runners may be used as appropriate. Other vane sizes, spacings or configurations are acceptable on designer approval.

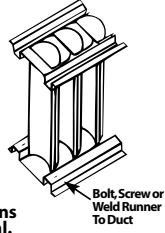

As Described on page 2.5, Figure 2-3 of the SMACNA HVAC Duct Construction Standards, 2nd Ed., 1995.

# Tools and Accessories

## **TDCRMP TDC/TDF CRIMPER TOOL**

The Dyn-O-Mate Crimper installs the TDC or TDF corner and crimps the edge over to hold the corner in place.

## **DOMCT CLEAT TOOL**

Install the finishing cleat quickly and easily. The tool pulls the ductwork tight while installing the cleat and creating a quick, easy and clean seal on duct connections over 48".

## **DYN-O-MATE ROD LOCK**

Available in 1/2" and 3/4" sizes, tie rods can be used to support duct sizes over 48", quickly and easily. It's as easy to use as a washer, Pull tested to over 1900 lbs., and available in sizes to meet your needs.

<b>Ordering Information</b>				
-----------------------------	--	--	--	--

Item #	Code	Description	Packaging	Weight (lbs.)
21070	DOMCT	DOM Cleat Tool	1 each	1
21072	TDCRMP	TDC/TDF Crimper	1 each	2
21097	DOMRL12	1/2" Rod Lock	250/Box	10
21098	DOMRL34	3/4" Rod Lock	250/Box	10
21076	RLT	Rod Lock Tool	1 each	1
21060	DOMNB38	3/8 in. Nuts & Bolts	125/Bag	8
21061	DOMNB14	1/4 in. Nuts & Bolts	125/Bag	3

## **GASKETING**

BTL500 Butyl and NEO750 Neoprene Gaskets offer an easy-to-use sealant to provide a moisture and vapor-tight seal to prohibit water and dust from any connection at any atmospheric pressure.

### **BUTYL GASKET**

- Butyl gasket is a permanently soft caulking compound with a high percentage of virgin butyl rubber.
- Butyl gasket can withstand movement without cracking.
- It will adhere to most dry, clean surfaces such as steel, aluminum, plastics, wood and concrete.
- Color: Grey, Black or Off White
- Temperature range: -40°f to 249°f
- Non-Corrosive

### **NEOPRENE GASKET**

- Neoprene gasket tape is a self-adhesive closed cell industrial foam comprised of neoprene, PVC and Nitrile.
- Great for use when connecting ductwork that might periodically have to be taken apart for maintenance purposes.
- Color: Black
- Temperature range: -40°f to 200°f
- Good chemical resistance.

<b>Ordering Information</b>				
-----------------------------	--	--	--	--

Item #	Code	Description	Packaging	Weight (lbs.)
21042	BTL500	Butyl Gasketing 25ft./Roll	500ft./Box	46
21043	NEO750	Neoprene Gasketing 50ft./Roll	750ft./Box	12
8261	BN316-34	TDC/TDF Neoprene Gasketing 50ft./Roll	1000ft./Box	14

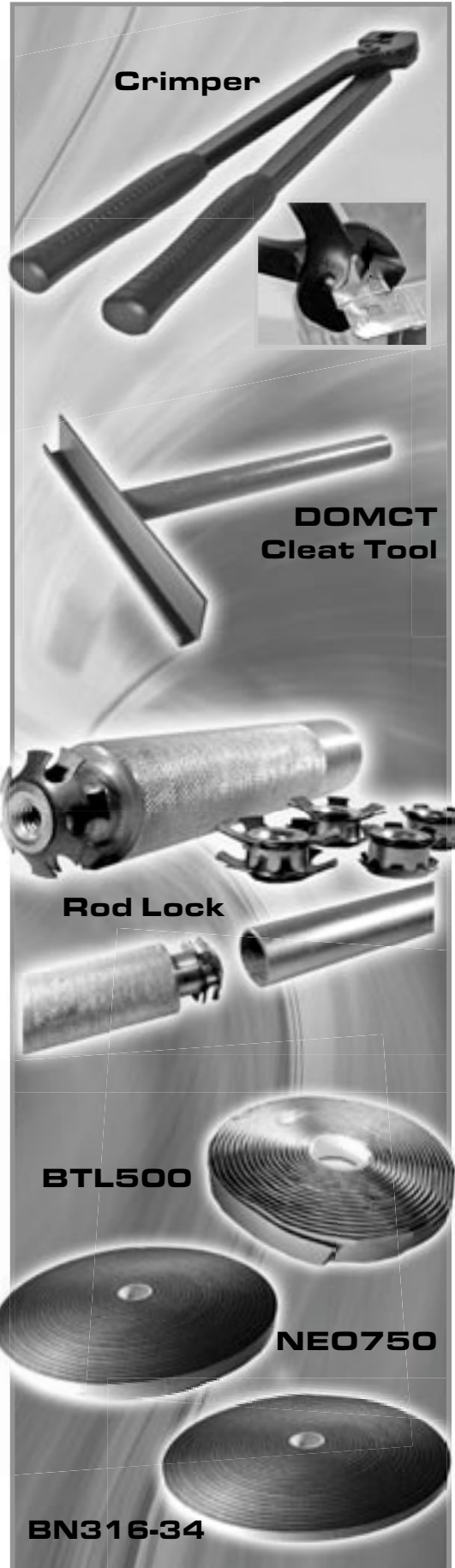

# Dyn-O-Mate Components

DYN-O-MATE COMPONENTS



## DYN-O-MATE COMPONENTS

Recommended for 26 ga. through and including 14 ga. ductwork

## Flanges

**J SYSTEM**  
 Rollformed from 20 ga. galvanized steel.  
 11 Ga. Galvanized Corner

**H SYSTEM**  
 Rollformed from 22 ga. galvanized steel.  
 12 Ga. Galvanized Corner

**SEALANT**  
 Flame Spread - 5  
 Smoke Density - 0  
 Fuel Contribution - 0  
 Life Expectancy - 20 year minimum

Large sealant pocket on all flange systems

## Corners

**J CORNER**  
 11 ga. galvanized steel

**H CORNER**  
 12 ga. galvanized steel

**DYN-O-MATE METAL CLEAT**

- Roll formed from 20 ga. galvanized steel
- Available in both 6" pieces and 10' lengths
- Suitable for driving in tight installations
- Also available in PVC

## Gasketing

**DYN-O-MATE GASKET**  
 Available in Butyl and Closed Cell Neoprene

<b><u>BUTYL GASKET</u></b>	<b><u>NEOPRENE GASKET</u></b>	<b><u>IDC/IDF NEOPRENE GASKET</u></b>
Flame Spread - 20	Flame Spread - 10	Flame Spread - 10
Fuel Contribution - 0	Fuel Contribution - 0	Fuel Contribution - 0
Smoke Density - 0	Smoke Density - 0	Smoke Density - 0
Thickness - 3/16"	Thickness - 5/16"	Thickness - 3/16"
Life Expectancy - 20 yr. min.	Unlimited Shelf Life	Unlimited Shelf Life
Flash Point - 300° F		
Compression set - none		

DYN-O-MATE



# Assembly Instructions

## DOMJ Flange & DOMH Flange

### 1. CUTTING THE ANGLE

The angle should be cut  $1 \frac{5}{16}$ " shorter than the duct dimensions, cutting the angle with the spine pointing up. Using a chop saw with a 3 h.p. motor and a metal cutting blade helps to insure a clean edge with no burrs.

### 2. FRAME ASSEMBLY AND SEATING

Using a mallet, insert the corners into the shorter angles; install the larger angles to complete the frame. The raised portion of the corner should be facing inward with the "Dyn-O-Mate" name visible from the outside.

Starting at a corner, use a mallet, hammer the completed frame onto the raw edge of the duct section. Moving in one direction, make sure the duct is seated into the mastic.

**NOTE:** The duct section should not be notched.

### 3. FASTENING THE FRAME

The frame can be fastened to the ductwork with either Hex Tex screws (10x3/4) or spot welds.

**NOTE:** On installations of 3" s.p. or above or on systems where leakage is to be less than 1% spot welding is recommended.

Tek screwing of the angle or spot welding must start within  $\frac{3}{4}$ " of each end of the angle at the duct section corners.

(See Chart on Next Page.)

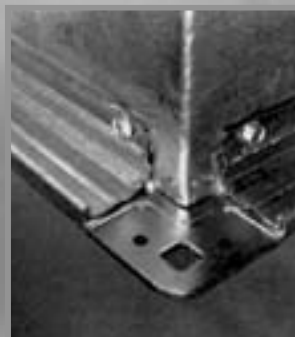
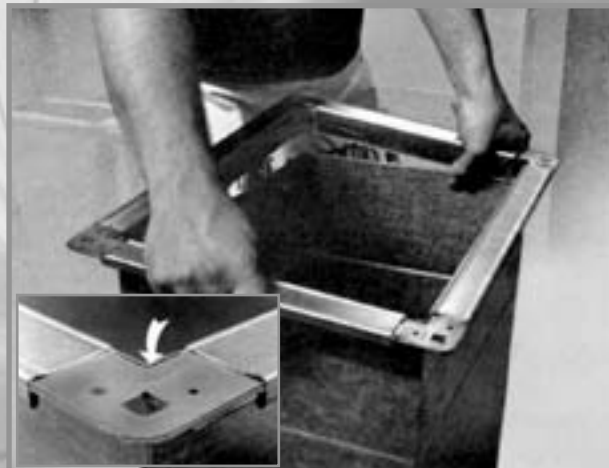

# Assembly Instructions

## DOMJ Flange & DOMH Flange

STATIC PRESSURE	DUCT SIZE	RECOMMENDED CENTERS
1/2" to 1"	To 48" 49" to 96" Over 96"	At 4 corners & centerline 30" centers 18" centers
1" to 2"	To 42" 43" to 96" Over 96"	At 4 corners & centerline 18" centers 12" centers
2" to 3"	To 36" 37" to 72" Over 72"	At 4 corners & centerline 18" centers 12" centers
3" to 6"	To 24" 25" to 60" Over 60"	At 4 corners & centerline 18" centers 12" centers
Over 6"	To 18" 19" to 48" Over 48"	At 4 corners & centerline 12" centers 8" centers

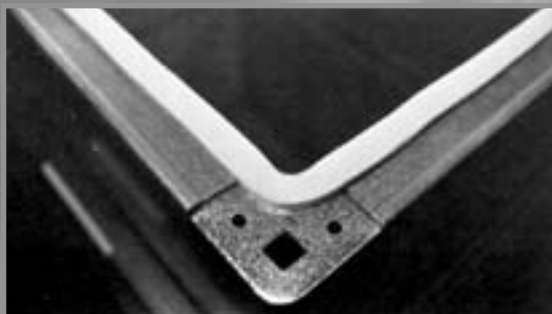

**Important:** Since sheet metal ductwork installations are sometimes used by the other trades as scaffolding, actual job conditions should really indicate the amount of spot welding and tek screwing.

### 4. GASKET APPLICATION

Apply a 2 to 3" strip of gasket on the 4 exposed corners of one frame, as pictured.

Starting at the center of the other mating frame, apply a single strap of gasket completely around the inside edge of the frame. **IMPORTANT:** This gasket must also cover the exposed edge of the duct section and the gap between the duct wall and the corner.

### 5. INSTALLING THE CLEAT

Snap a 6" piece of either metal or PVC cleat over the mating frame, using the following recommendations:

1/2" to 2" sp - 1 piece on 24" centers  
 2" to 3" sp - 1 piece on 18" centers  
 4" to 6" sp - 1 piece on 12" centers  
 Over 10" sp - continuous cleat



To Whom It May Concern:

SUBJECT: Duct construction other than that in the HVAC-DCS-1985

The foreword of the 1985 HVAC-DCS states that "Although standardization intrinsically involves selection, no intention of discrimination against the use of any product or method that would serve a designer's need equally or better exists." Additionally, recognition of equivalent or other construction is acknowledged in the text as follows:

1. Italicized wording in paragraph one on page 1-12 states "a fifth alternative, that of using non-illustrated construction, is recognized based on sponsor demonstrated equivalency subject to the approval of authorities regulating use of this voluntary acceptance standard. SMACNA does not validate equivalency."
2. Text on page 1-14 states that "certain joints have been assigned maximum pressure classes. Such restrictions are not intended to prohibit consideration of other limits where evidence of acceptability is presented under the equivalent construction principle."
3. Paragraph S 1.18 on page 1-15 states that "Other construction that meets the functional criteria in Section VII or is as serviceable as that produced by the construction tables may be provided."
4. A sentence on page 1-37 says "See Figure 1-4A for commentary on proprietary joint systems and see Section VII for joint performance evaluation."
5. The text on page 1-38 "invites authorities to consider alternative constructions" and says "consult the manufacturers of alternative systems for ratings, assembly requirements and recommendations."
6. Note 3 on page IV states that "the Association refrains from endorsement of proprietary products." Note 4 on this page says "the Association will not review or judge products or components as being in compliance with the document."
7. Paragraph S 3.3 on page 3-2 says "Nothing herein is intended to constitute implied disapproval of the designer's consideration of other methods of construction."
8. Paragraph S 3.26 on page 3-13 states that "Illustrations of accessories and sleeves and collars are representative of a class of such items and are not intended to preclude the use of components not precisely identical to these."
9. Three alternative procedures for rating construction relative to the SMACNA tables are given on page 7-5, analysis, historical track record and testing. Commentary on witnessing tests and on use of test data is provided in the last paragraph on page 7-11, ending with "Authorities are invited to evaluate such construction based on evidence presented by sponsors." Otherwise, the performance criteria used for the SMACNA rectangular duct tables are given in Section VII. General performance requirements are discussed on page 1-3.

We think that these statements from the HVAC-DCS reflect a clear policy of SMACNA's abstention from judging unillustrated components and systems as being equivalent while encouraging consideration of them based on evidence presented by sponsors. Otherwise, SMACNA has not published or authorized any addenda for the 1985 HVAC-DCS.

Sincerely,

John H. Stratton  
Director, Technical Services



1/2" W.G.  
Static  
pos. or neg  
Duct  
Dimen.

**SHOP STANDARDS**  
**RECTANGULAR DUCT REINFORCEMENT**  
Minimum Rigidity Class\* - Minimum Gage Duct  
Reinforcement Spacing

R=Midpoint Reinforcement  
T=Conduit Type Tie Rods

\*=These tests were done as comparative tests, and the actual duct deflection was not recorded. They did not exceed SMACNA Deflection Standards.

Note: Two (2) Tie Rods - equally spaced (28" centerline) were used

	8'	6'	5'	4'	3'	2 1/2'	2'
26" dn	H-26	H-26	H-26	H-26	H-26	H-26	H-26
27-30"	H-26	H-26	H-26	H-26	H-26	H-26	H-26
31-36"	H-24	H-26	H-26	H-26	H-26	H-26	H-26
37-42"	H-24	H-24	H-26	H-26	H-26	H-26	H-26
43-48"	H-22	H-24	H-26	H-26	H-26	H-26	H-26
49-54"	H-20	H-22	H-26	H-26	H-26	H-26	H-26
55-60"	H-20	H-22	H-24	H-24	H-26	H-26	H-26
61-72"	H-18	H-20	H-22	J26T	H-24	H-24	H-24
73-84"	J-16	H-18	H-22	J26T	H-24	H-24	H-24
85-96"	J-16	J-18	J22T	H-20	J22	H-22	H-22
97-108"			J22T	J-18	J22T	J-18	J22T
109-120"			J22T		J22T	J-18	J22T

When referring to Table 1-3 thru Table 1-10 in the SMACNA HVAC Duct Construction Standards, 2<sup>nd</sup> ed., 1995,

Use the Dyn-O-Mate "H" Angle on Rigidity Class "F", "G" and "H"  
Use the Dyn-O-Mate "J" Angle on Rigidity Classes above "H"

The tables as shown here are the SMACNA Tables with those interpretations already substituted.

These tests results are shown as follows:

SMACNA Table



Variation permitted per certified test.

1" W.G.  
Static  
pos or neg  
Duct  
Dimen.

## SHOP STANDARDS RECTANGULAR DUCT REINFORCEMENT Minimum Rigidity Class\* - Minimum Gage Duct Reinforcement Spacing

R=Midpoint Reinforcement  
T=Conduit Type Tie Rods

\*=These tests were done as comparative tests, and the actual duct deflection was not recorded. They did not exceed SMACNA Deflection Standards.

Note: Two (2) Tie Rods - equally spaced (28" centerline) were used

	8'	6'	5'	4'	3'	2 1/2'	2'					
14" dn	H-26	H-26	H-26	H-26	H-26	H-26	H-26					
15-20"	H-26	H-26	H-26	H-26	H-26	H-26	H-26					
21-24"	H-24	H-26	H-26	H-26	H-26	H-26	H-26					
25-30"	H-24	H-26	H-26	H-26	H-26	H-26	H-26					
31-36"	H-22	H-24	H-24	H-26	H-26	H-26	H-26					
37-42"	H-20	H-22	H-24	H-26	H-26	H-26	H-26					
43-48"	H-18	H-20	H-22	H-26	H-26	H-26	H-26					
49-54"	H-18	H-20	H-22	J-26	H-24	J-26	H-24	J-26	H-24	J-26	H-24	J-26
55-60"	H-18	H-20	H-22	J-26	H-24	J-26	H-24	J-26	H-24	J-26	H-24	J-26
61-72"		H-18	H-18	J <sup>24</sup> <sub>26T</sub>	H-22	J26T	H-24	J26T	H-24	J-26	H-24	J-26
73-84"		J-16	J-18	J24T	J-20	J22	H-22	J22	H-22	J-24	H-22	J-24
85-96"			J-16	J-20	J-18	J-20	J-20	J22	H-20	J-22		H-22
97-108"				J22T	J-18	J22T	J-18	J22T	J-18	J-22	J-18	J-22
109-120"				J22T		J22T	J-18	J22T	J-18	J-22	J-18	J-22

\* Each duct system shall be constructed for the specific duct pressure classifications shown on the contract drawings for the project. Where no specific duct pressure class designations are provided by the designer the 1" water gage pressure class is the basis of compliance with these standards, regardless of velocity in the duct, except when the duct is variable volume: All variable volume duct upstream of VAV boxes has a 2" w.g. basis of compliance when the designer does not give a pressure class.

\*Because total pressure decreases in the direction of the flow a duct construction pressure classification equal to fan outlet pressure (or to fan total static pressure rating) cannot economically be imposed on the entire duct system. Pressure in ducts near room air terminals is nearly always below 1/2" w.g.

\*Asterisks indicate wording that is taken directly and verbatim from the SMACNA HVAC Duct Construction Standards, 2nd ed., 1995.

**SMACNA TABLE 1-2 DUCT SEALING REQUIREMENTS**

Seal Class Class	Sealing Required	Static Pressure Construction Class
A	All transverse joints, longitudinal seams and duct wall penetrations	4" w.g. and up
B	All transverse joints and longitudinal seams	3" w.g.
C	Transverse Joint	2" w.g.

In addition to the above, any variable air volume system duct of 1" and 1/2" w.g. construction class that is up stream of the VAV boxes shall meet Seal Class C.

2" W.G.  
Static  
pos or neg  
Duct  
Dimen.

## SHOP STANDARDS RECTANGULAR DUCT REINFORCEMENT

### Minimum Rigidity Class\* - Minimum Gage Duct Reinforcement Spacing

R=Midpoint Reinforcement  
T=Conduit Type Tie Rods

\*=These tests were done as comparative tests, and the actual duct deflection was not recorded. They did not exceed SMACNA Deflection Standards.

Note: Two (2) Tie Rods - equally spaced (28" centerline) were used

	8'	6'	5'	4'	3'	2 1/2'	2'
12" dn	H-26	H-26	H-26	H-26	H-26	H-26	H-26
13-18"	H-24	H-24	H-26	H-26	H-26	H-26	H-26
19-26"	H-22	H-24	H-26	H-26	H-26	H-26	H-26
27-30"	H-20	H-22	H-24	H-26	H-26	H-26	H-26
31-36"	H-18	H-20	H-22	H-24	H-26	H-26	H-26
37-42"	H-16	H-18	H-20	H-24	H-24	H-26	H-26
43-48"	J-16	H-18	H-20	H-22	J26T	H-24	H-24
49-54"		J-16	H-18	J 22 26T	H-20	J 22 26T	H-24
55-60"		J-16	J-18	J 22 26T	H-18	J 22 26T	H-24
61-72"			J-16	J24T	J-18	J26T	H-22
73-84"				J22T	J-18	J22T	J-20
85-96"				J22T	J-18	J22T	J-20
97-108"				JT22T	JT22T	K-18	JT22T
109-120"				JT22T	JT22T	K-18	JT22T

### Tie Rod Installations TIE ROD OPTION CONSTRUCTION:

Using the Dyn-O-Mate RODLOCK(Conduit Type Tie Rod) Duro Dyne Corp., through a certified testing Program (in accordance with Chapter 7 of the SMACNA HVAC Duct Construction Standards, 2<sup>nd</sup> ed. 1995) has used the Conduit Type Tie Rod being attached to the duct wall alone as the reinforcement for the panel tie rod.

Example: 22 T Center tie rod:

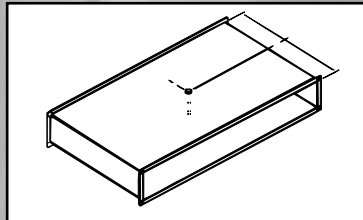

Where the Conduit Type Tie Rod is used as a flange reinforcement, "JT" or "HT", the conduit type tie rod is installed as shown below:

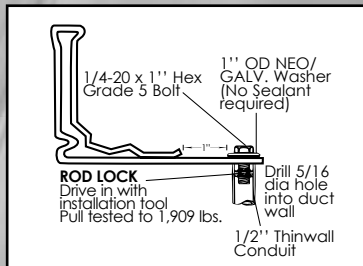

### Negative Pressure

**NOTE: Do not use internal duct wall supports (tie rods) on negative pressure duct systems without first consulting with the Duro Dyne Corp.**



3" W.G.  
Static  
pos or neg  
Duct  
Dimen.

## SHOP STANDARDS RECTANGULAR DUCT REINFORCEMENT

**Minimum Rigidity Class\* - Minimum Gage Duct Reinforcement Spacing**

R=Midpoint Reinforcement  
T=Conduit Type Tie Rods

\*=These tests were done as comparative tests, and the actual duct deflection was not recorded. They did not exceed SMACNA Deflection Standards.

Note: Two (2) Tie Rods - equally spaced (28" centerline) were used

	8'	6'	5'	4'	3'	2 1/2'	2'
12" dn	H-24	H-26	H-26	H-26	H-26	H-26	H-26
13-18"	H-22	H-24	H-24 H-26	H-26	H-26	H-26	H-26
19-22"	H-20	H-22	H-24 H-26	H-24 H-26	H-26	H-26	H-26
23,24"	H-18	H-22	H-24 H-26	H-24 H-26	H-26	H-26	H-26
25,26"	H-18	H-22	H-24	H-24	H-26	H-26	H-26
27,28"	H-18	H-20	H-22 H-24	H-24	H-26	H-26	H-26
29,30"	H-18	H-20	H-22 H-24	H-24	H-26	H-26	H-26
31-36"	H-16	H-18	H-20 H-24	H-22 H-24	H-24 H-24	H-26	H-26
37-42"		H-18	H-20 H-24	H-22 H-24	H-24 H-24	H-24 H-24	H-26
43-48"		J-16	J-18 J26T	H-20 J26T	H-22	H-24	H-24
49-54"			J-18 J26T	J-18 J26T	H-22	H-24	H-24
55-60"			J-16 J24T	J-18 J24T	H-20	H-22	H-24
61-72"			J24T	J-16 J24T	J-20 J24T	J-22 J-24	J-24
73-84"			J20T	J20T	J-18 J20T	J-20 J-22	J-22
85-96"			JT20T	JT20T	K-18 JT20T	J-18 J-20	J-20
97-108"			JT20T	JT20T	JT20T	L-18 JT20	K-18 JT20
109-120"			JT20T	JT20T	JT20T	L-18 JT20	L-18 JT20

This table shows some typical duct sizes and the weight that can be saved by changing gage per certified test:

SMACNA Table  Variation permitted per certified test.

Duct Size	Sq. Ft. per 5" Sect.	Lbs./Sq. Ft.	Lbs./Sq. Ft.	Lbs./Sq. Ft.	Lbs./Sq. Ft.	Lbs./Sq. Ft.
		.91 26 ga.	1.16 24 ga.	1.41 22 ga.	1.66 20 ga.	2.16 18 ga.
30/18	40	40	51	62	73	95
36/24	50	50	64	76	83	119
42/24	55	55	70	85	100	131
48/24	60	60	76	93	110	143
54/24	65	65	83	101	119	154
60/30	75	75	96	116	137	178
72/36	90	90	115	140	164	214
84/48	110	110	140	171	201	261
96/48	120	120	153	186	219	285

**SHOP STANDARDS**  
**RECTANGULAR DUCT REINFORCEMENT**  
 Minimum Rigidity Class\* - Minimum Gage Duct Reinforcement Spacing

4" W.G.  
 Static  
 pos or neg  
 Duct  
 Dimen.

R=Midpoint Reinforcement  
 T=Conduit Type Tie Rods

\*=These tests were done as comparative tests, and the actual duct deflection was not recorded. They did not exceed SMACNA Deflection Standards.

Note: Two (2) Tie Rods - equally spaced (28" centerline) were used

	8'	6'	5'	4'	3'	2 1/2'	2'
10" dn	H-22	H-26	H-26	H-26	H-26	H-26	H-26
11,12"	H-22	H-24	H-26	H-26	H-26	H-26	H-26
13,14"	H-22	H-22	H-24	H-26	H-26	H-26	H-26
15,16"	H-20	H-22	H-24	H-26	H-26	H-26	H-26
17-20"	H-20	H-22	H-24	H-24	H-26	H-26	H-26
21,22"	H-18	H-20	H-24	H-24	H-26	H-26	H-26
23,26"	H-18	H-20	H-22	H-24	H-24	H-26	H-26
27-30"	H-18	H-18	H-22	H-24	H-24	H-24	H-26
31-36"		H-18	H-20	H-22	H-22	H-24	H-26
37-42"		J-16	J-18	H-22	H-20	H-22	H-24
43-48"			J-18	J26T	J-18	J26T	H-24
49-54"			J-16	J24T	J-18	J24T	J-20
55-60"			J-16	J22T	J-16	J22T	J-20
61-72"				J20T		J20T	J-18
73-84"				J20T		J20T	K-16
85-96"				JT20T		JT20T	J-18
97-108"				JT18T		JT18T	L-18
109-120"				JT18T		JT18T	L-18

**PRECAUTIONS**

In any given duct system, accidental overpressure could occur and must be accounted for by design provisions, such as fail safe features, replaceable release panels and static pressure switches that can shut down the entire system. Note: On all duct systems that are to be tested for leakage, it is recommended that the first 100 feet of completed ductwork be tested before proceeding to complete the installation.

**SHIPPING L SHAPED DUCT WITH THE ANGLE INSTALLED**

**STEP ONE**

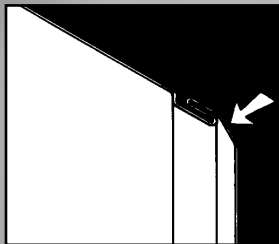

Notch the "hammer edge" of the female Pittsburgh Lock 1/4" on a 45 degree angle as shown.

**STEP TWO**

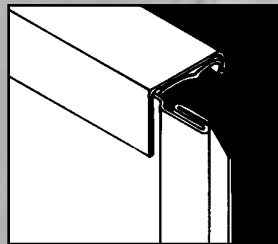

In the shop, install the angle on the duct without the corner piece.

**STEP THREE**

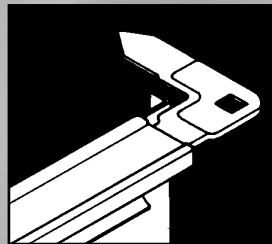

In the field insert a corner piece into the angle at the male end of the Pittsburgh Lock.

**STEP FOUR**

Complete the frame and bend over the hammer edge of the Pittsburgh Lock in the standard manner.

6" W.G.  
Static  
pos or neg  
Duct  
Dimen.

## SHOP STANDARDS RECTANGULAR DUCT REINFORCEMENT

### Minimum Rigidity Class\* - Minimum Gage Duct Reinforcement Spacing

R=Midpoint Reinforcement  
T=Conduit Type Tie Rods

\*=These tests were done as comparative tests, and the actual duct deflection was not recorded. They did not exceed SMACNA Deflection Standards.

Note: Two (2) Tie Rods - equally spaced (28" centerline) were used

	8'	6'	5'	4'	3'	2 1/2'	2'					
10" dn	H-20	H-22	H-26	H-26	H-26	H-26	H-26					
11,12"	H-20	H-22	H-24	H-24	H-26	H-26	H-26					
13,14"	H-20	H-20	H-22	H-24	H-26	H-26	H-26					
15,18"	H-18	H-20	H-22	H-24	H-26	H-26	H-26					
19-22"	H-18	H-20	H-22	H-24	H-24	H-26	H-26					
23,24"	H-18	H-20	H-22	H-22	H-24	H-26	H-26					
25,28"	H-16	H-18	H-20	H-22	H-24	H-24	H-24					
29-30"		H-18	H-18	H24T	H-22	H-24	H-24					
31-36"		J-16	J-18	H24T	H-20	H-22	H-24					
37-42"			J-16	H24T	J-18	H24T	H-20	H-22	H-24	H-22	H-24	
43-48"				H24T	J-18	H24T	J-18	H-22	J-22	H-24	H-22	H-24
49-54"				J20T	J-16	J20T	J-18	J-20	J-20	J-22	J-20	J-22
55-60"				J20T		H20T	J-18	H20T	J-20	J-20	J-22	J-20
61-72"				JT20T		JT20T	K-16	JT20T	J-18	J-20	J-20	J-20
73-84"				JT20T		JT20T		JT20T	L-16	JT20	K-18	JT20
85-96"				JT18T		JT18T		JT18T	IT16	JT18	L-18	JT18
97-108"				JT18T		JT18T		JT18T	JT16	JT18	L-18	JT18
109-120"				JT18T		JT18T		JT18T	KT16	JT18	KT18	JT18

#### Dyn-O-Mate Angle as a Breakaway Connection

- A. Dyn-O-Mate frame.  
Use neoprene gasket between the frames. Secure duct to sleeve.
- B. Retaining angle, secured to sleeve only.
- C. Fire damper secured to sleeve.
- D. 20 ga. Sleeve up to 54" x 54" - 18 ga. Sleeve 54" and up.
- E. Melt away (200°F) pvc cleat (typ). Install 6" pieces 12" on center starting cleat at extreme end (corners).

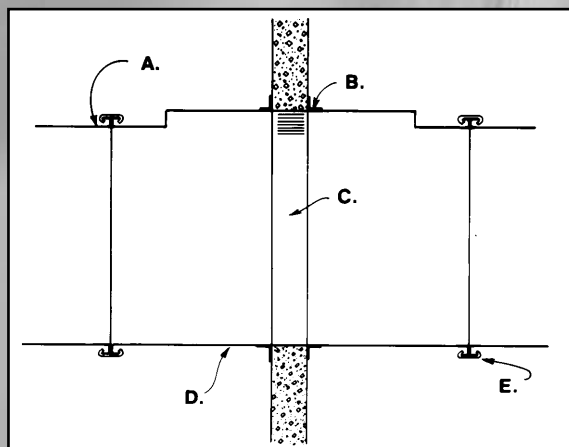

**NOTE:** Install duct and fire damper sleeve per normal installation procedures with bolts at the corners until all ductwork is installed and testing is completed. After successful testing, the bolts at the corners of the fire damper sleeves are to be removed so as to insure that duct will break away once cleats reach melting temperature of 200 degrees F.

10" W.G.  
Static  
pos or neg  
Duct  
Dimen.

## SHOP STANDARDS RECTANGULAR DUCT REINFORCEMENT

### Minimum Rigidity Class\* - Minimum Gage Duct Reinforcement Spacing

R=Midpoint Reinforcement  
T=Conduit Type Tie Rods

\*=These tests were done as comparative tests, and the actual duct deflection was not recorded. They did not exceed SMACNA Deflection Standards.

Note: Two (2) Tie Rods - equally spaced (28" centerline) were used

	8'	6'	5'	4'	3'	2 1/2'	2'
8" dn	H-20	H-22	H-24	H-24	H-26	H-26	H-26
9",10"	H-20	H-20	H-22	H-24	H-26	H-26	H-26
11",12"	H-18	H-20	H-22	H-24	H-26	H-26	H-26
13",14"	H-18	H-18	H-20	H-22	H-24	H-26	H-26
15-18"	H-16	H-18	H-20	H-20	H-24	H-24	H-26
19",20"	H-16	H-18	H-18	H-20	H-22	H-24	H-24
21-24"		H-18	H-18	H-20	H-22	H-24	H-24
25-28"		J-16	J-18	H-18	H-22	H-24	H-24
29",30"			J-16	J-18	H-22	H-24	H-24
31-36"			J-16	J-18	J-20	H-22	H-24
37-42"			J16T	J-16	J-18	J-20	J-22
43-48"				JT16	J-18	J-18	J-22
49-54"					K-16 JT16	J-18	J-20
55-60"					L-16 JT16	K-18 JT18	J-20
61-72"						L-16 JT16	L-18 JT18
73-84"							LT16 JT16
85-96"							LT16 JT16
97-108"							LT16 JT16
109-120"							LT16 JT16

**Compliance to the 1998 California Mechanical Code Addendum.**

**NOTE:**

METAL NOSING MUST BE USED WHEREVER LINER IS PRECEDED BY UNLINED METAL; OTHERWISE WHEN VELOCITY EXCEEDS 4000 FPM (20.3 MPS) USE METAL NOSING ON EVERY LEADING EDGE.

AS DESCRIBED ON PAGE 2.24, FIGURE 2-19 OF THE SMACNA HVAC DUCT CONSTRUCTION STANDARDS, 2ND ED., 1995

← AIR FLOW

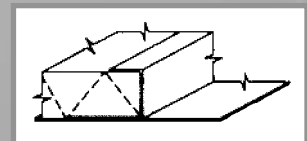

DETAIL A



## TEST RESULTS

The following tests of rectangular duct sections and transverse joints were conducted in accordance with Section VII of the SMACNA HVAC Duct Construction Standards, 2nd ed., 1995.

Operating Pressure	Duct Size	Section Length	Duct Gauge	Connector Type	Connector Deflection	Duct Deflection
1"	72/12	60"	18 ga.	H	.249	.650
1"	48/12	60"	26 ga.	H	.050	.750
1"	60/21	60"	26 ga.	J	.060	.750
1"	84/12	60"R	24 ga.	J	.072	.384
1"	96/12	60"	20 ga.	J	.290	.750
1"	84/21	60"T	26 ga.	J	.060	.350
2"	60/21	60"T	26 ga.	J	.050	.010
2"	84/12	48"	18 ga.	J	.250	.740
2"	72/12	60"R	24 ga.	H	.258	.725
2"	72/12	60"	19 ga.	J	.230	.650
2"	48/12	60"	24 ga.	H	.120	.820
2"	84/36	60"R	20 ga.	J	.168	.670
2" see note	84/21	60"T	26 ga.	J	.040	.468
3"	48/12	60"	20 ga.	H	.165	.730
3"	72/12	60"R	24 ga.	J	.140	.702
3"	60/12	60"	18 ga.	J	.131	*
3"	76/44	60"R	20 ga.	J	.220	.500
3"	60/15	60"	16 ga.	H	.148	.740
3"	60/21	60"T	26 ga.	J	.090	.040
4"	72/12	60"R	24 ga.	J	.231	.498
4"	48/12	60"R	24 ga.	H	.164	.498
4"	48/12	60"	20 ga.	H	.245	.830
4"	60/12	60"	18 ga.	J	.160	*
4"	76/44	60"R	20 ga.	J	.278	.600
4"	60/21	60"T	26 ga.	J	.120	.100
5"	48/12	60"R	24 ga.	H	.210	.525
5"	48/12	60"	18 ga.	H	.250	<.750
5"	60/12	60"	18 ga.	J	.211	*
6"	60/12	48"R	20 ga.	H	.215	.730
6"	48/12	60"R	24 ga.	H	.259	.620
6"	48/12	60"	18 ga.	H	.300	.780
6"	60/12	60"	18 ga.	J	.279	*
10"	42/12	48"	16 ga.	H	.200	.730
10"	108/58	60"R	18 ga.	J	.250	<.750
10"	120/42	48"R	16 ga.	J	.100	<.750
10"	42/24	60"R	16 ga.	J	.090	.340

R=Midpoint Reinforcement  
 T=Conduit Type Tie Rods  
 \*=These tests were done as comparative tests, and the actual duct deflection was not recorded. They did not exceed SMACNA Deflection Standards.  
 Note: Two (2) Tie Rods - equally spaced (28" centerline) were used

**Rectangular Duct Deflection Limits**  
 (As Taken from the SMACNA HVAC Duct Construction Standards, 2nd ed., 1995.)

DUCT WALL	LIMIT
W=12" or less	3/8"
W=13" to 18"	1/2"
W=19" to 24"	5/8"
W=25" to 84"	3/4"
W=85" to 120"	1"
Tolerance of +10%	
JOINTS & REINFORCEMENTS	LIMIT
W=48" or less	1/4"
W=49" to 120"	W/200
Tolerance of 7.5%	

# TO PLACE AN ORDER...

Contact The Duro Dyne Sales Office.

23

MAP OF LOCATIONS

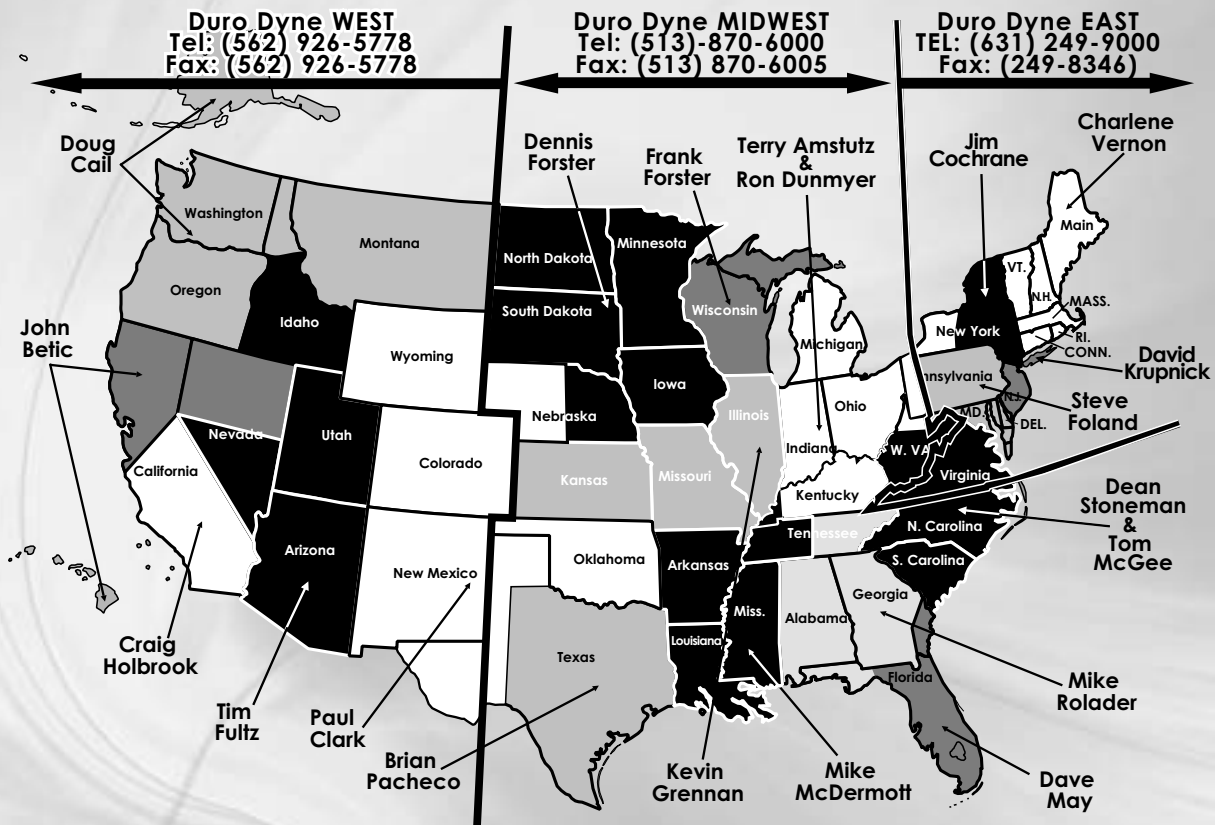

**Amstutz, Terry**

Indiana  
Kentucky  
Michigan  
New York  
Pennsylvania  
Ohio  
West Virginia

**Betic, John**

California  
Hawaii  
Nevada

**Cail, Doug**

Alaska  
Idaho  
Montana  
Oregon  
Washington

**Clark, Paul**

Colorado  
Nebraska  
New Mexico  
Oklahoma  
Texas  
Wyoming

**Cochrane, Jim**

New Jersey  
New York

**Dunmyer, Ron**

Indiana  
Kentucky  
Michigan  
New York  
Ohio  
Pennsylvania  
West Virginia

**Foland, Steve**

Delaware  
Maryland  
New Jersey  
Pennsylvania  
Virginia

**Forster, Dennis**

Iowa  
Minnesota  
Nebraska  
North Dakota  
South Dakota

**Forster, Frank**

Michigan  
Wisconsin

**Fultz, Tim**

Arizona  
Idaho  
Nevada  
Utah

**Grennan, Kevin**

Illinois  
Kansas  
Kentucky  
Missouri

**Holbrook, Craig**

California

**Krupnick, David**

New Jersey  
New York

**May, Dave**

Alabama  
Florida  
Georgia

**McDermott, Mike**

Arkansas  
Louisiana  
Mississippi  
Tennessee

**McGee, Tom**

Pennsylvania  
North Carolina  
South Carolina  
Virginia  
West Virginia

**Pacheco, Brian**

Texas

**Rolader, Mike**

Alabama  
Georgia  
Florida  
Tennessee

**Stoneman, Dean**

Pennsylvania  
North Carolina  
South Carolina  
Virginia  
West Virginia

**Vernon, Charlene**

Connecticut  
Maine  
Massachusetts  
New Hampshire  
Rhode Island  
Vermont

DYNOCHIMATE

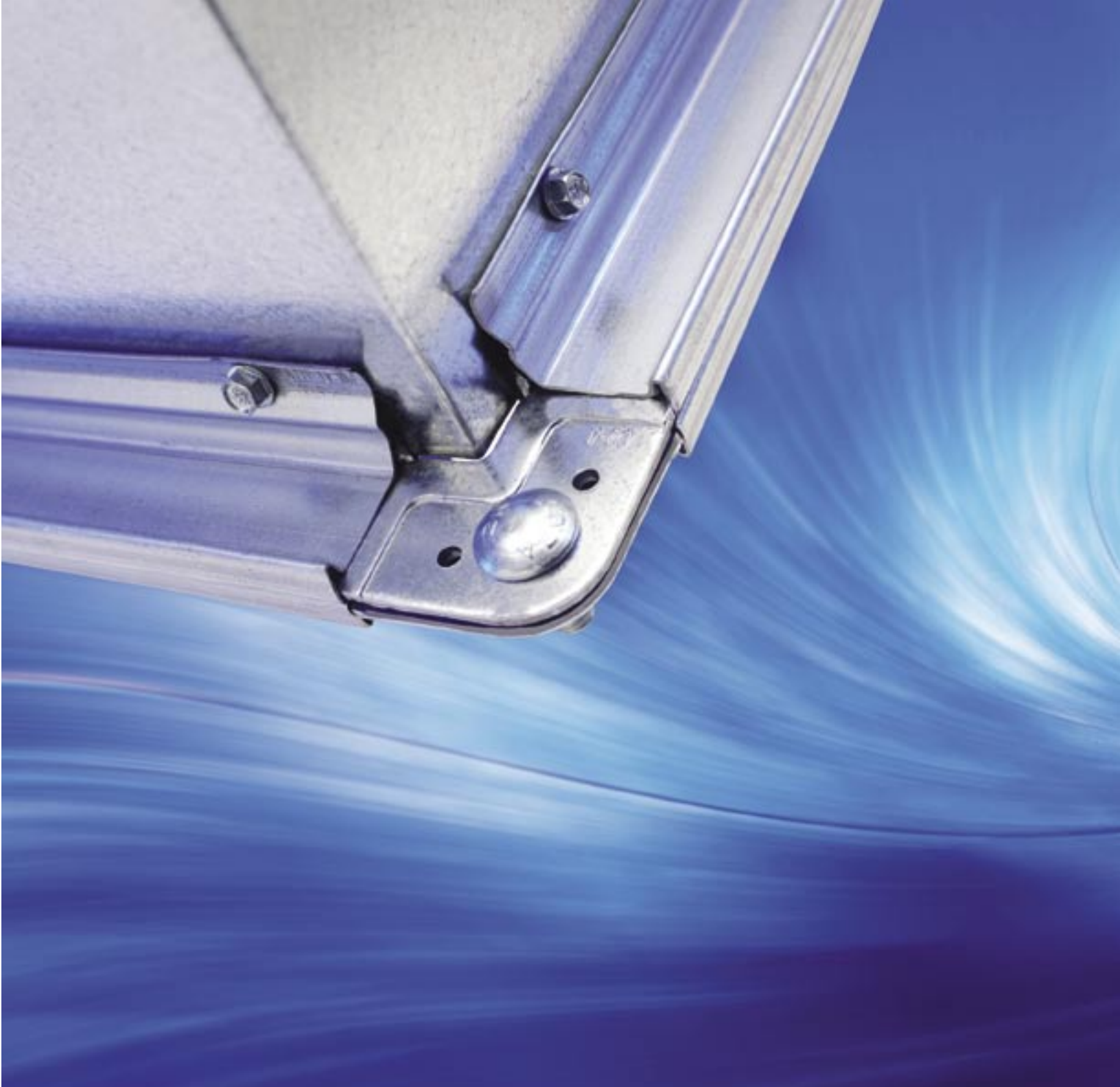

© Duro Dyne Corp.  
Printed in USA 6/06  
BB021502

<b>Duro Dyne East Division, Bay Shore, NY</b>	<b>631-249-9000</b>	<b>Fax: 631-249-8346</b>
<b>Duro Dyne Midwest Division, Fairfield, OH</b>	<b>513-870-6000</b>	<b>Fax: 513-870-6005</b>
<b>Duro Dyne West Division, Santa Fe Springs, CA</b>	<b>562-926-1774</b>	<b>Fax: 562-926-5778</b>
<b>Duro Dyne Canada, Lachine, Quebec, Canada</b>	<b>514-422-9760</b>	<b>Fax: 514-636-0328</b>

**www.durodyne.com E-mail: durodyne@durodyne.com**