

Sale Model:

MS11M-
24HRDN1-

Factory Model:

US1-KFR67G/BP2N1Y-11M1(T0)-W

Product Code:

220033005030

Power Supply:

208-230V~ 60Hz 1Phase

Accessory part

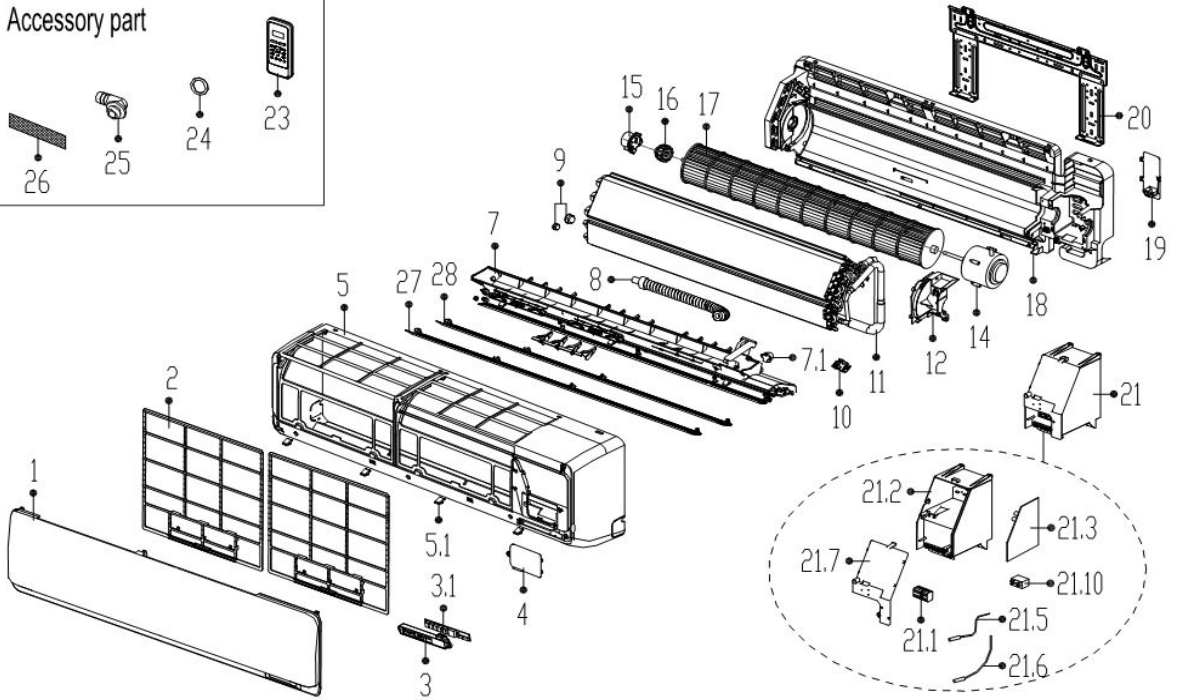
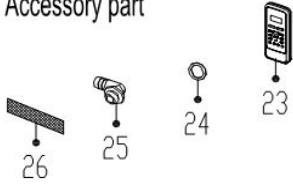

No.	Part Name	Quantity	BOM Code
1	Panel assembly	1	201133090997
2	Air filter	2	201133090992
3	Display box assembly	1	203332390972
3.1	Display board assembly	1	201332391249
4	Cover of electrical equipment	1	201119901024
5	Panel frame assembly	1	201133090996
5.1	Screw cap	4	201119900950
7	Air outlet assembly	1	201133091008
7.1	Louver motor	1	202400200070
8	Drain hose	1	201101020038
9	Pipe nut	1	201600330004
9	Pipe nut	1	201600330002
10	Fix clamp of temperature sensor	1	201102000305
11	Evaporator assembly	1	201533090143

12	Fan motor cover	1	201133090991
14	Asynchronous motor	1	202400401301
15	Bearing holder	1	201119900952
16	Bearing base	1	202719900606
17	Cross flow fan	1	201100200057
18	Chassis assembly	1	201133090995
19	Pipe clamp board	1	201133090989
20	Installation plate	1	201232990002
21	Electronic control box assembly	1	203333090523
21.1	Wire joint	1	202301450119
21.2	Electronic control box	1	201133190200
21.3	Indoor main control board assembly	1	201333090769
21.5	Ambient temperature sensor assembly	1	202301300210
21.6	Pipe temperature sensor assembly	1	202301300426
21.7	Cover of electronic control box	1	201133190184
21.8	Power module assembly	1	201333090408
21.10	Fan motor capacitor	1	202401100354
23	Remote Controller	1	203355091532
24	Seal ring	1	202720090001
25	Drain joint	1	201101020011
26	Air freshening filter	1	201131410703
27	Horizontal louver (above)	1	201133090993
28	Horizontal louver (below)	1	201133090999