

# Installer's Guide

---

## Condensing Units

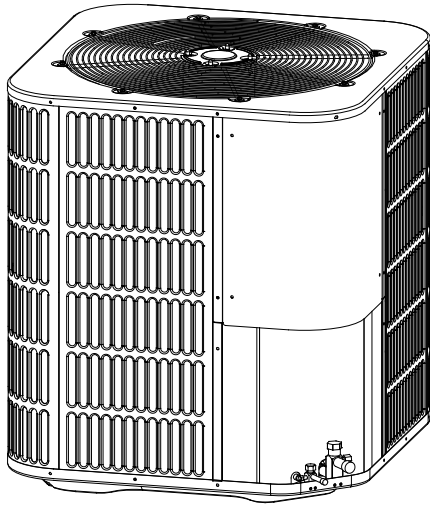

**X DRIVE SERIES**  
Split System Heat Pump & Air Conditioner  
Up to 18 SEER  
2-5 Tons  
R410A

**NOTE:** Appearance of unit may vary.



ALL phases of this installation must comply with NATIONAL, STATE AND LOCAL CODES

---

**IMPORTANT** — This document is customer property and is to remain with this unit. Please return to service information pack upon completion of work.

These instructions do not cover all variations in systems or provide for every possible contingency to be met in connection with the installation. Should further information be desired or should particular problems arise which are not covered sufficiently for the purchaser's purposes, the matter should be referred to your installing dealer or local distributor.

**Note :** *The manufacturer recommends installing only approved matched indoor and outdoor systems. All of the manufacturer's split systems are A.H.R.I. rated only with TXV indoor systems. And the indoor units must be matched with TXV. Some of the benefits of installing approved matched indoor and outdoor split systems are maximum efficiency, optimum performance and the best overall system reliability.*

<b>Table of Contents</b>	
<b>Section 1. Safety</b> .....	<b>2</b>
<b>Section 2. Unit Location Considerations</b> .....	<b>3</b>
<b>Section 3. Unit Preparation</b> .....	<b>5</b>
<b>Section 4. Setting the Unit</b> .....	<b>5</b>
<b>Section 5. Refrigerant Line Considerations</b> .....	<b>6</b>
<b>Section 6. Refrigerant Line Routing</b> .....	<b>7</b>
<b>Section 7. Refrigerant Line Brazing</b> .....	<b>8</b>
<b>Section 8. Refrigerant Line Leak Check</b> .....	<b>10</b>
<b>Section 9. Evacuation</b> .....	<b>11</b>
<b>Section 10. Service Valves</b> .....	<b>11</b>
<b>Section 11. Electrical - Low Voltage</b> .....	<b>12</b>
<b>Section 12. Electrical - High Voltage</b> .....	<b>14</b>
<b>Section 13. Start Up</b> .....	<b>15</b>
<b>Section 14. System Charge Adjustment</b> .....	<b>16</b>
<b>Section 15. System operation and Troubleshooting</b> .....	<b>20</b>

## Section 1. Safety

**Important** - This document contains a wiring diagram and service information. This is customer property and is to remain with this unit. Please return to service information pack upon completion of work.



### CAUTION

This information is intended for use by individuals possessing adequate backgrounds of electrical and mechanical experience. Any attempt to repair a central air conditioning product may result in personal injury and/or property damage. The manufacturer or seller cannot be responsible for the interpretation of this information, nor can it assume any liability in connection with its use.



### WARNING

#### HAZARDOUS VOLTAGE!

Failure to follow this warning could result in property damage, severe personal injury, or death. Disconnect all electric power, including remote disconnects before servicing. Follow proper lockout/tagout procedures to ensure the power cannot be inadvertently energized.



### WARNING

#### REFRIGERANT OIL!

Any attempt to repair a central air conditioning product may result in property damage, severe personal injury, or death.

These units use R-410A refrigerant which operates at 50 to 70% higher pressures than R-22. Use only R-410A approved service equipment. Refrigerant cylinders are painted a "Rose" color to indicate the type of refrigerant and may contain a "dip" tube to allow for charging of liquid refrigerant into the system. The R410 system of 2/3 tons with MITSUBISHI variable compressor uses PVE oil ( FV50S or equal ), and the R410 system of 4/5 tons with GMCC variable compressor uses POE oil ( VG74 or equal ). Both of them readily absorb moisture from the atmosphere. To limit this "hygroscopic" action, the system should remain sealed whenever possible. If a system has been opened to the atmosphere for more than 4 hours, the compressor oil must be replaced. Never break a vacuum with air and always change the driers when opening the system for component replacement.



### WARNING

#### HIGH CURRENT LEAKAGE !

Failure to follow this warning could result in property damage, severe personal injury, or death. Earth connection essential before connecting electrical supply.



### CAUTION

#### CONTAINS REFRIGERANT!

Failure to follow proper procedures can result in personal illness or injury or severe equipment damage. System contains oil and refrigerant under high pressure. Recover refrigerant to relieve pressure before opening system.



### CAUTION

#### GROUNDING REQUIRED!

Failure to inspect or use proper service tools may result in equipment damage or personal injury. Reconnect all grounding devices. All parts of this product that are capable of conducting electrical current are grounded. If grounding wires, screws, straps, clips, nuts, or washers used to complete a path to ground are removed for service, they must be returned to their original position and properly fastened.



### CUTION

#### INDOOR UNIT REQUIRED!

The indoor unit must be matched with TXV. And the model of TXV can be charged according to the system capacity



### WARNING

#### SERVICE VALVES!

Failure to follow this warning will result in abrupt release of system charge and may result in personal injury and/or property damage. Extreme caution should be exercised when opening the Liquid Line Service valve. Turn valve stem counterclockwise only until the stem contacts the rolled edge. No torque is required.



### WARNING

#### BRAZING REQUIRED!

Failure to inspect lines or use proper service tools may result in equipment damage or personal injury. If using existing refrigerant lines make certain that all joints are brazed, not soldered.



### CAUTION

#### HOT SURFACE!

May cause minor to severe burning. Failure to follow this caution could result in property damage or personal injury. Do not touch top of compressor.

## Section 2. Unit Location Considerations

### 2.1 Unit Dimensions

Unit Dimensions	
Models	H x W x L (Inches)
24/36	24-15/16 x 29-1/8 x 29-1/8
48/60	33-3/16 x 29-1/8 x 29-1/8

The unit's weight values is on the carton box.

When mounting the outdoor unit on a roof, be sure the roof will support the unit's weight. Properly selected isolation is recommended to prevent sound or vibration transmission to the building structure.

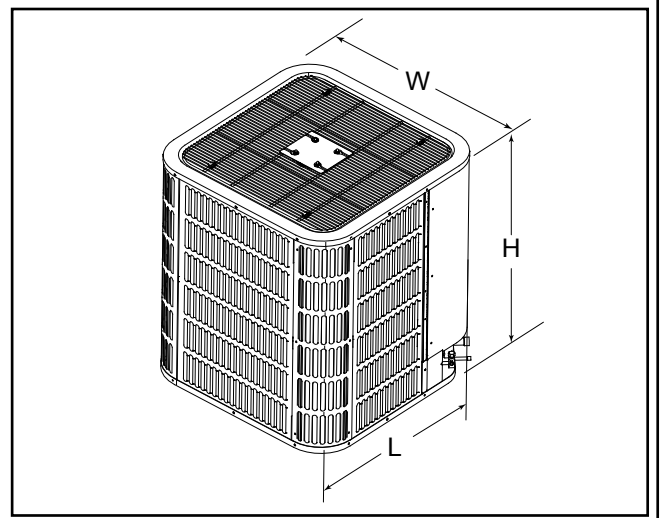

### 2.2 Refrigerant Piping Limits

- Maximum line equivalent length = 100 feet.
- Maximum vertical equivalent length = 50 feet.
- Use only the line diameters indicated in Table 5.1.
- If the suction line sets are greater than 60 feet do not use a larger suction line than recommended.

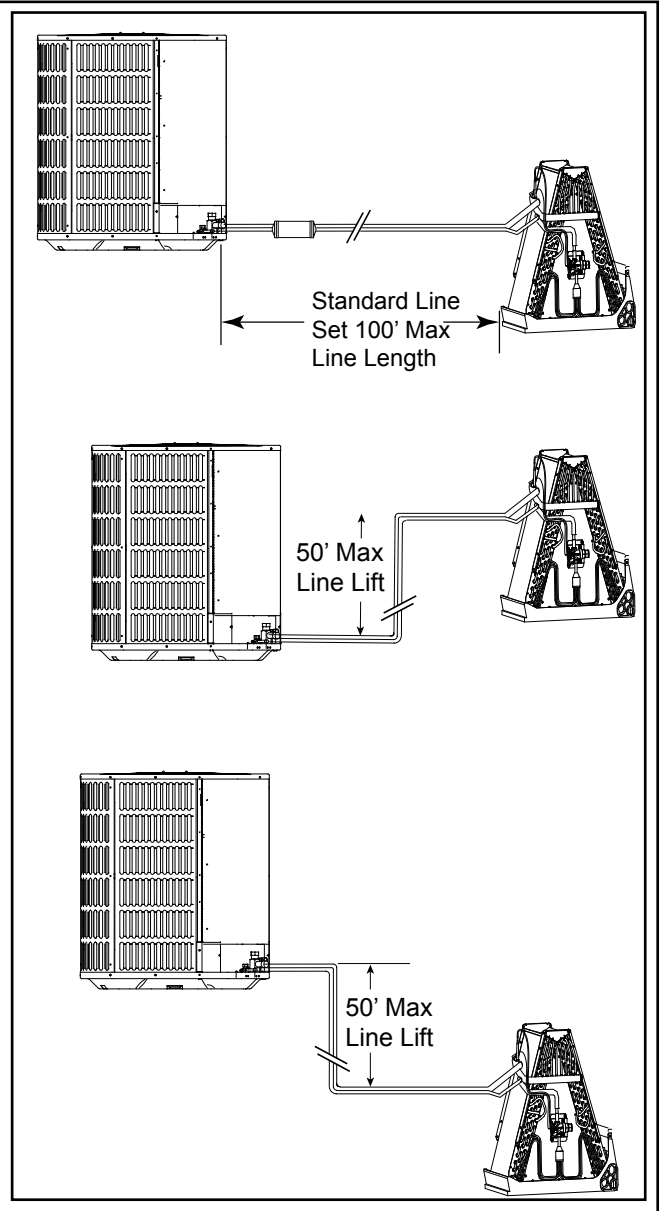

## 2.4 Location Restrictions

Ensure the top discharge area is unrestricted for at least 60 inches above the unit.

Clearance must be provided in front of the control box (access panels) and any other side requiring service.

Do not locate outdoor unit near bedrooms since normal operational sounds may be objectionable.

Position unit to allow adequate space for unobstructed airflow, wiring, refrigerant lines, and serviceability.

Allow a minimum of 12 in. clearance on one side of access panel to a wall and a minimum of 24 in. on the adjacent side of access panel.

Maintain a distance of 24 in. between units.

Position unit so water, snow, or ice from roof or overhang cannot fall directly on unit.

Only use this unit in well-ventilated spaces and ensure that there are no obstructions that could impede the airflow into and out of the unit.

Do not use this unit in the following locations:

- Locations with mineral oil.
- Locations with saline atmospheres, such as seaside locations.
- Locations with sulphurous atmospheres, such as near natural hot springs.
- Where high voltage electricity is present, such as in certain industrial locations.
- On vehicles or vessels, such as trucks or ferry boats.
- Where exposure to oily or very humid air may occur, such as kitchens.
- In proximity to sources of electromagnetic radiation, such as high-frequency transmitters or other high strength radiation devices.

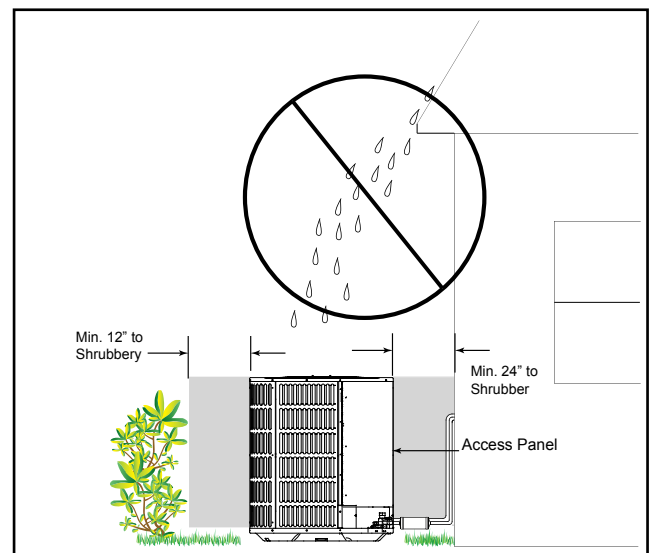
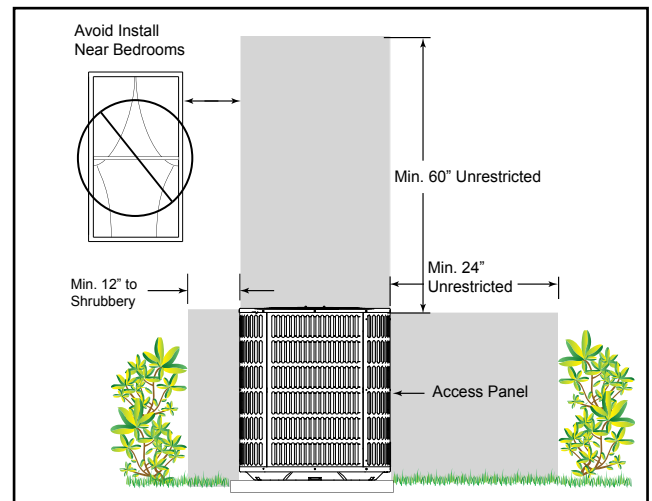

### Cold Climate Considerations (Heat Pump Only)

Note: It is recommended that these precautions be taken for units being installed in areas where snow accumulation and prolonged below-freezing temperatures occur.

- Units should be elevated 3-12 inches above the pad or rooftop, depending on local weather. This additional height will allow drainage of snow and ice melted during defrost cycle prior to its refreezing. Ensure that drain holes in unit base pan are not obstructed, preventing drainage of defrost water.
- If possible, avoid locations that are likely to accumulate snow drifts. If not possible, a snow drift barrier should be installed around the unit to prevent a build-up of snow on the sides of the unit.

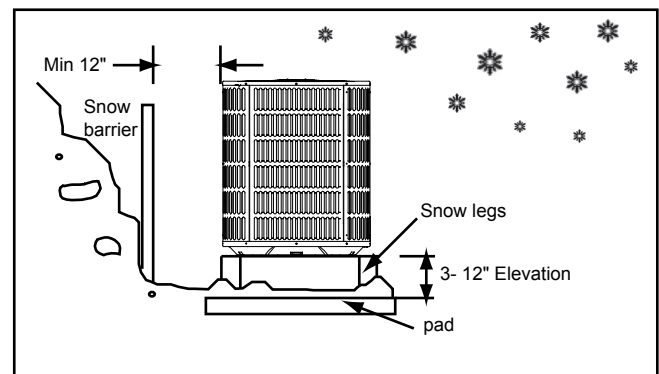

## Section 3. Unit Preparation

### 3.1 Prepare The Unit For Installation

**STEP 1** - Check for damage and report promptly to the carrier any damage found to the unit.

The charge port can be used to check to be sure the refrigerant charge has been retained during shipment.

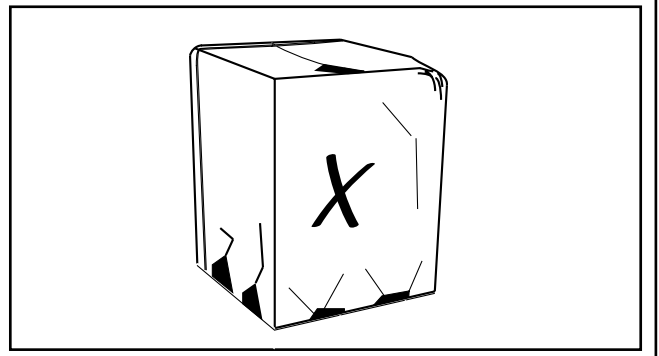

## Section 4. Setting the Unit



### WARNING

#### LIVE ELECTRICAL COMPONENTS!

Check the electric wire, water and gas pipeline layout inside the wall, floor and ceiling before installation. Do not implement drilling unless confirm safety with the user, especially for the hidden power wire. An electroprobe can be used to test whether a wire is passing by at the drilling location, to prevent physical injury or death caused by insulation broken cords.

### 4.1 Pad Installation

When installing the unit on a support pad, such as a concrete slab, consider the following:

- The pad should be at least 1-2" larger than the unit on all sides.
- The pad must be separate from any structure.
- The pad must be level.
- The pad should be high enough above grade to allow for drainage.
- The pad location must comply with National, State, and Local codes.

#### IMPORTANT NOTE:

These instructions are intended to provide a method to tie-down system to cement slab as a securing procedure for high wind areas. It is recommended to check Local Codes for tie-down methods and protocols.

#7 X 3/8" Self Tapping Screws  
(Don't Exceed 3/8" long)

DETAIL A

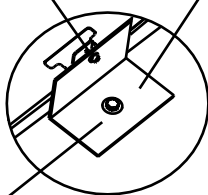

Brackets:  
2" width, 1/16" thickness,  
height as required.  
Available from distributor  
or in market place.

1/4" X 1-1/2" Hex Washer Head Concrete Screws  
(3/16" Pilot Hole Needed. Pilot Hole Should Be 1/4" Deeper  
Than The Fastener Embedment)

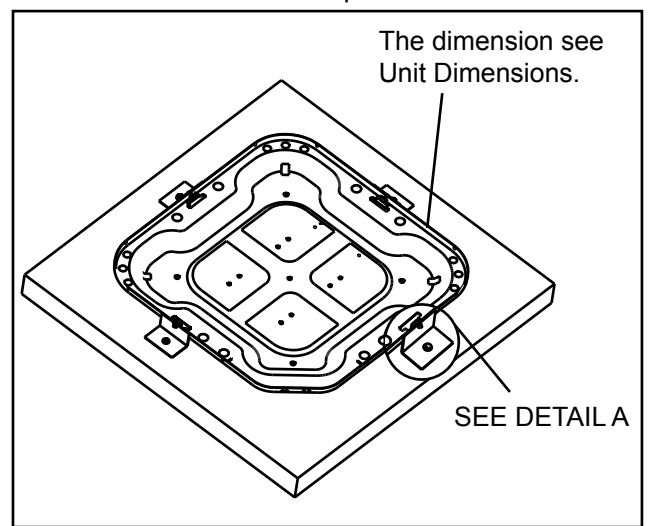
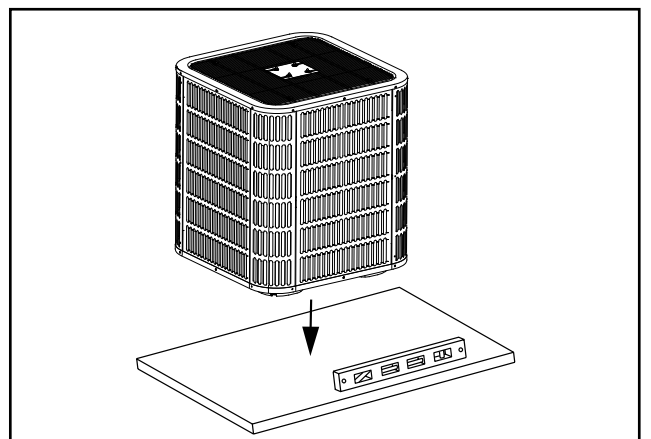

## Section 5. Refrigerant Line Considerations

### 5.1 Refrigerant Line and Service Valve Connection Sizes

Table 5.1

Model	Line Sizes		Service Valve Connection Sizes	
	Suction Line	Liquid Line	Suction Line Connection	Liquid Line Connection
24/36	3/4	3/8	3/4	3/8
48/60	7/8	3/8	7/8	3/8

### 5.2 Required Refrigerant Line Length

Determine required line length.

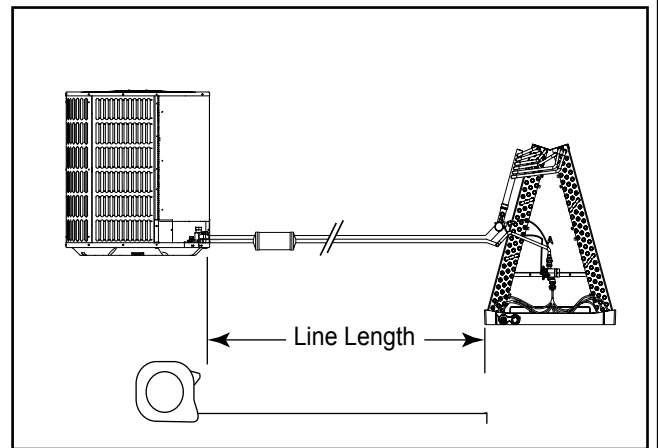

### 5.3 Refrigerant Line Insulation

**Important:** The Suction Line must always be insulated. DO NOT allow the Liquid Line and Suction Line to come in direct (metal to metal) contact.

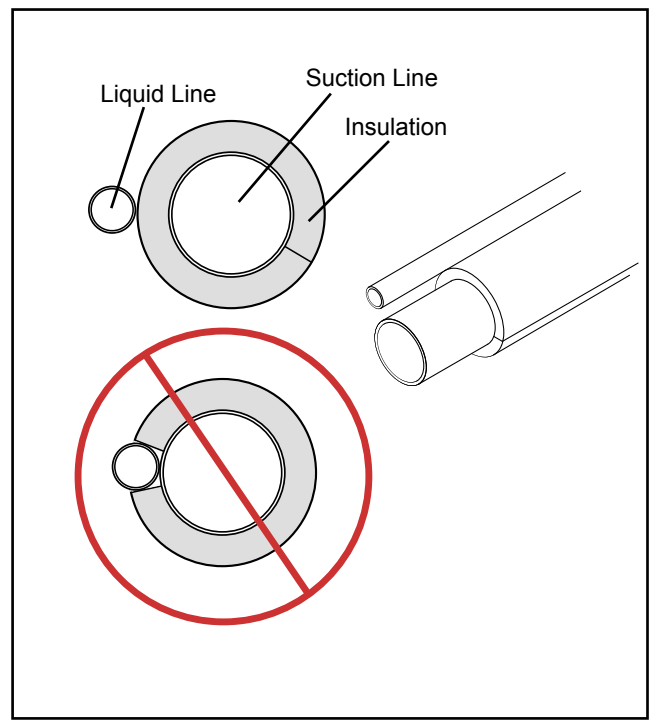

## 5.4 Reuse Existing Refrigerant Lines

### ⚠ CAUTION

If using existing refrigerant lines make certain that all joints are brazed, not soldered.

For retrofit applications, where the existing refrigerant lines will be used, the following precautions should be taken:

- Ensure that the refrigerant lines are the correct size. Refer to Section 2.2 listed and Table 5.1.
- Ensure that the refrigerant lines are free of leaks, acid, and oil.

**Note:** The manufacturer recommends installing only approved matched indoor and outdoor systems. All of the manufacturer's split systems are A.H.R.I. rated only with TXV indoor systems. Some of the benefits of installing approved matched indoor and outdoor split systems are maximum efficiency, optimum performance and the best overall system reliability.

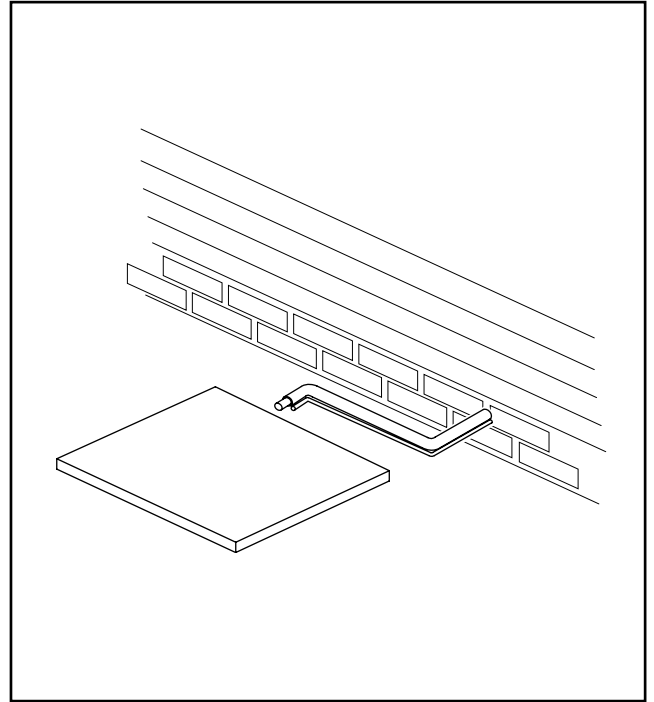

## Section 6. Refrigerant Line Routing

### 6.1 Precautions

**Important:** Take precautions to prevent noise within the building structure due to vibration transmission from the refrigerant lines.

Comply with National, State, and Local Codes when isolating line sets from joists, rafters, walls, or other structural elements.

For Example:

- When the refrigerant lines have to be fastened to floor joists or other framing in a structure, use isolation type hangers.
- Isolation hangers should also be used when refrigerant lines are run in stud spaces or enclosed ceilings.
- Where the refrigerant lines run through a wall or sill, they should be insulated and isolated.
- Isolate the lines from all ductwork.
- Minimize the number of 90° turns.

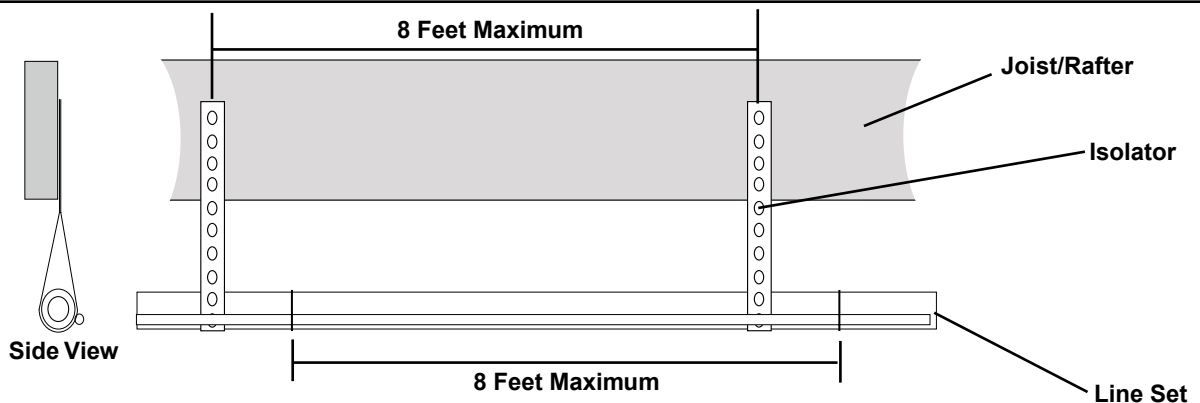

Secure Suction line from joists using isolators every 8 ft. Secure Liquid Line directly to Suction line using tape, wire, or other appropriate method every 8 ft.

Isolation From Joist/Rafter

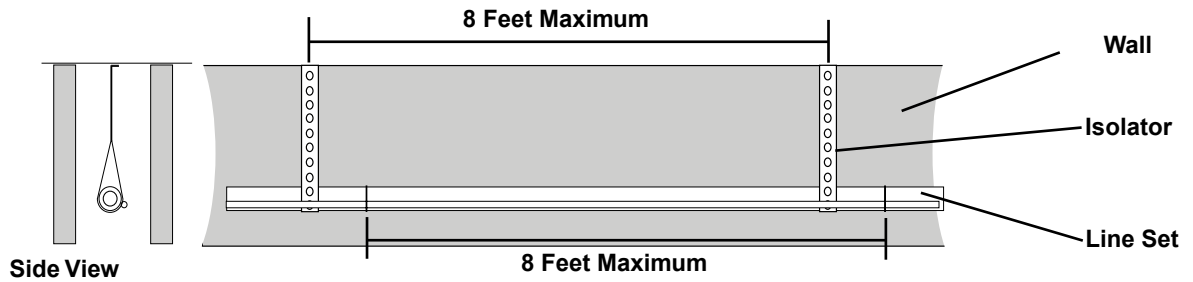

Secure Suction Line using isolators every 8 ft. Secure Liquid Line directly to Suction Line using tape, wire, or other appropriate method every 8 ft.

Isolation In Wall Spaces

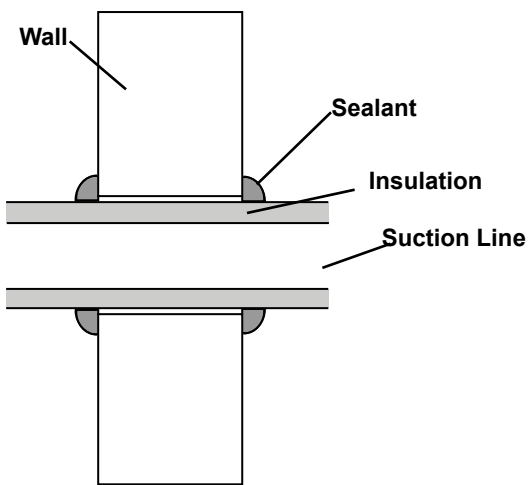

Isolation Through Wall

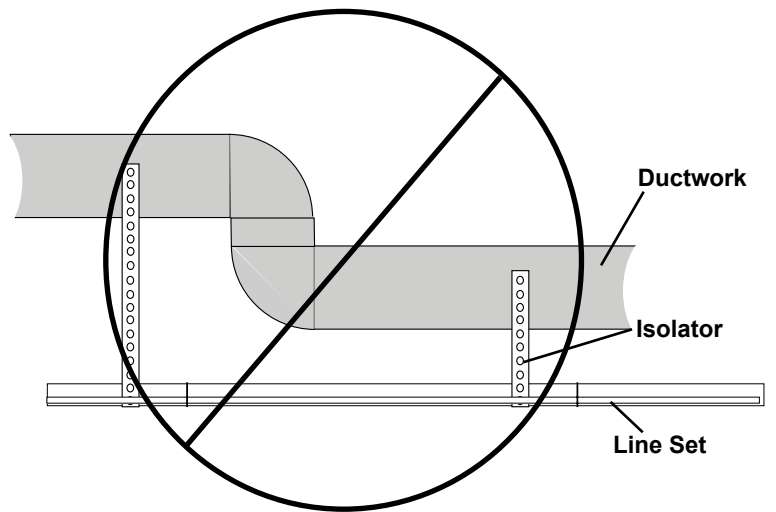

DO NOT hang line sets from ductwork

## Section 7. Refrigerant Line Brazing

### 7.1 Braze The Refrigerant Lines

**STEP 1** - Remove caps or plugs. Use a deburring tool to deburr the pipe ends. Clean both internal and external surfaces of the tubing using an emery cloth.

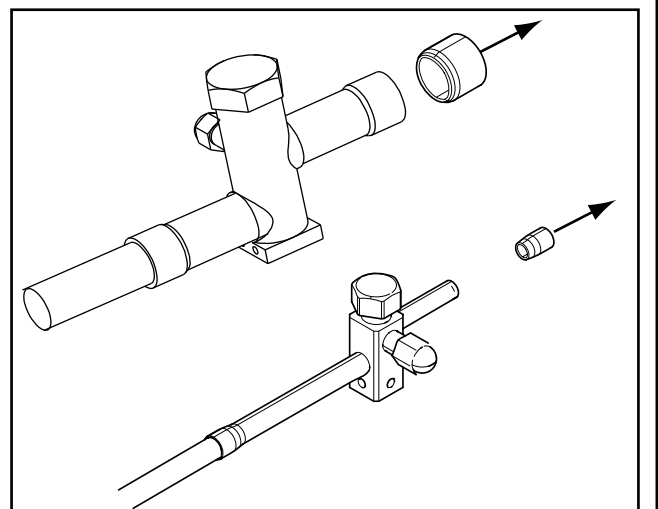



**STEP 2** - Remove the pressure tap cap from both service valves.

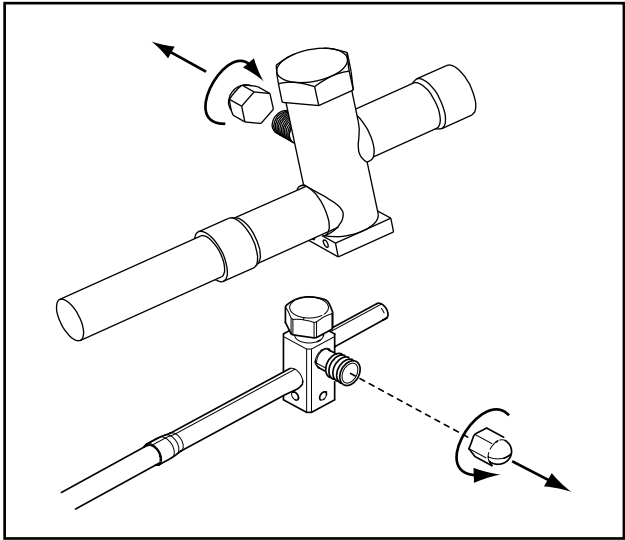

**STEP 3** - Purge the refrigerant lines and indoor coil with dry nitrogen.

This pipe must have a thimble

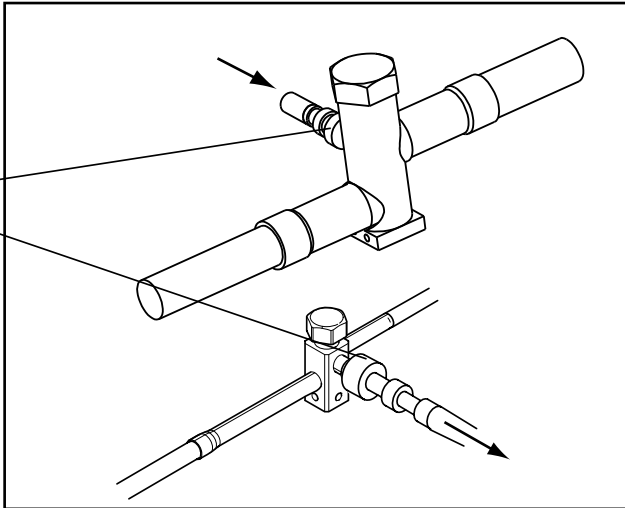

**STEP 4** - Wrap a wet rag around the valve body to avoid heat damage and continue the dry nitrogen purge.

Braze the refrigerant lines to the service valves.

Check liquid line filter drier's directional flow arrow to confirm correct direction of refrigeration flow (away from outdoor unit and toward evaporator coil) as illustrated. Braze the filter drier to the Liquid Line.

Continue the dry nitrogen purge. Do not remove the wet rag until all brazing is completed.

Important: Remove the wet rag before stopping the dry nitrogen purge.

**Note:** Install drier in Liquid Line.

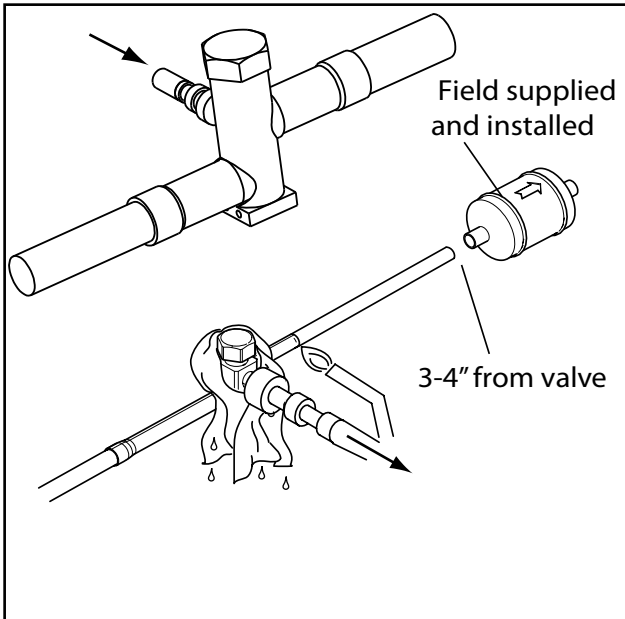

**STEP 5** - Replace the pressure tap caps after the service valves have cooled.

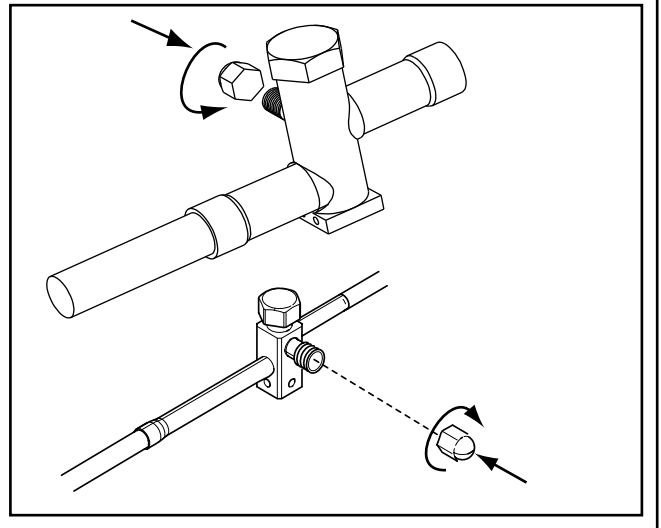

## Section 8. Refrigerant Line Leak Check

### 8.1 Check For Leaks

**STEP 1** - Pressurize the refrigerant lines and evaporator coil to 150 PSIG using dry nitrogen.

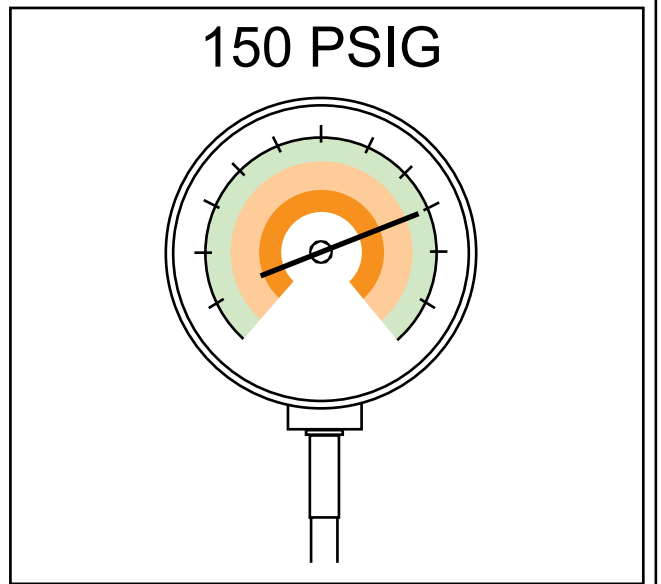

**STEP 2** - Check for leaks by using a soapy solution or bubbles at each brazed location.

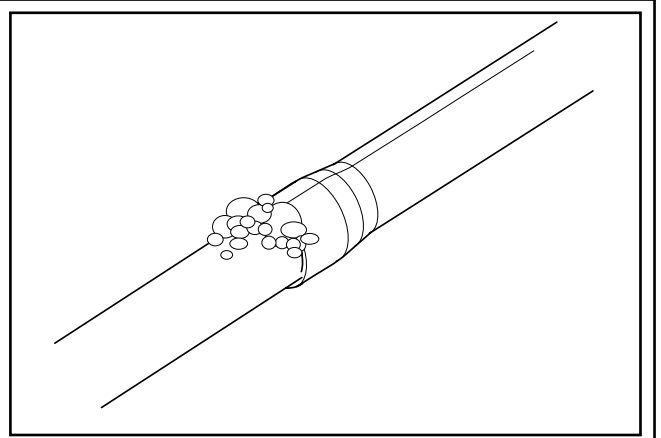

## Section 9. Evacuation

### 9.1 Evacuate the Refrigerant Lines and Indoor Coil

**Important:** Do not open the service valves until the refrigerant lines and indoor coil leak check and evacuation are complete.

**STEP 1-** Evacuate until the micron gauge reads no higher than 350 microns, then close the valve to the vacuum pump.

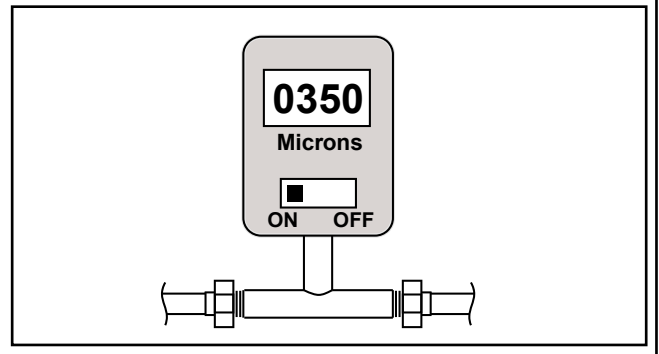

**STEP 2-** Observe the micron gauge. Evacuation is complete if the micron gauge does not rise above 500 microns in one (1) minute.

Once evacuation is complete blank off the vacuum pump and micron gauge, and close the valves on the manifold gauge set.

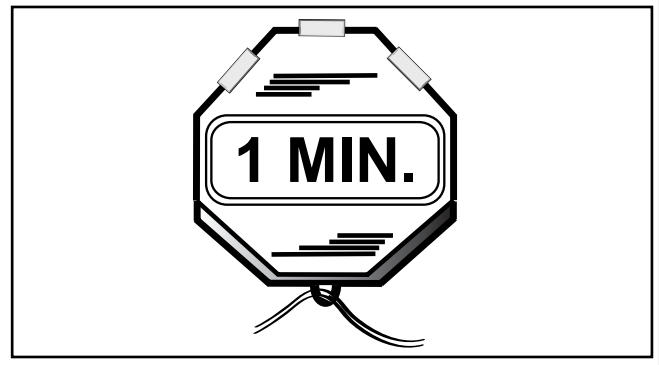

## Section 10. Service Valves

### 10.1 Open the Service Valves

#### ⚠ WARNING

Extreme caution should be exercised when opening the Liquid Line Service Valve. Turn counterclockwise until the valve stem just touches the rolled edge. No torque is required. Failure to follow this warning will result in abrupt release of system charge and may result in personal injury and /or property damage.

**Important:** Leak check and evacuation must be completed before opening the service valves.

**Important:** The Suction Service Valve must be opened first BEFORE opening the Liquid Service Valve!

**STEP 1** - Remove service valve cap.

**STEP 2** - Fully insert hex wrench into the stem and back out counterclockwise until valve stem just touches the rolled edge (approximately five (5) turns.)

**STEP 3** - Replace the valve stem cap to prevent leaks. Tighten finger tight plus an additional 1/6 turn.

**STEP 4** - Repeat STEPS 1 - 3 for Liquid Service Valve.

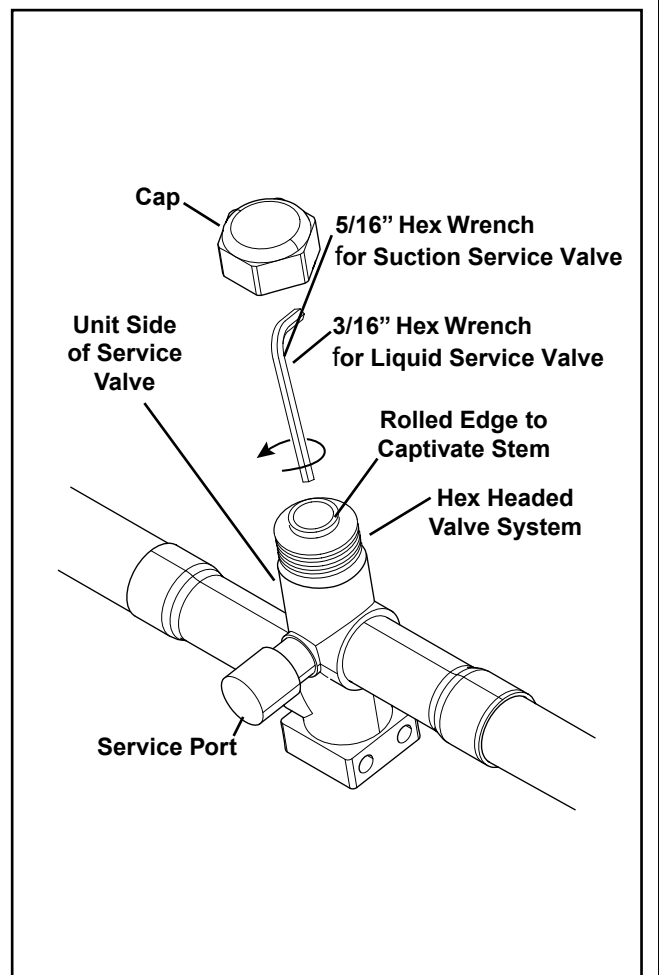

# Section 11. Electrical - Low Voltage

## 11.1 Low Voltage Maximum Wire Length

Table 11.1 defines the maximum total length of low voltage wiring from the outdoor unit, to the indoor unit, and to the thermostat.

Field provided bushing or strain relief is required at the low voltage wire entry point.

**Table 11.1**

24 VOLTS	
WIRE SIZE	MAX. WIRE LENGTH
18 AWG	150 Ft.
16 AWG	225 Ft.
14 AWG	300 Ft.

## 11.2 Low Voltage Hook-up Diagrams

### Air Handler Hook-up Diagram

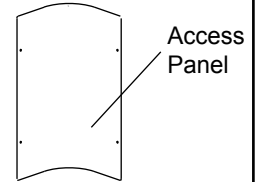
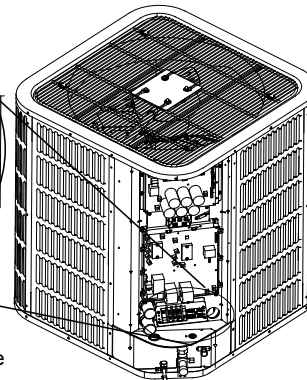
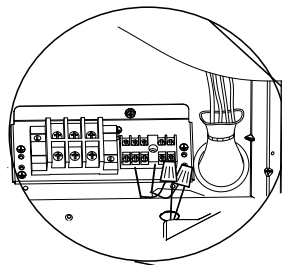
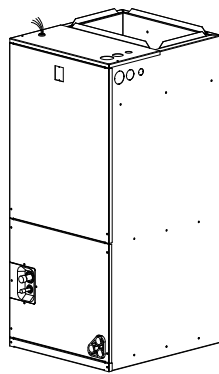

Low Voltage connection must be made inside the outdoor unit case.

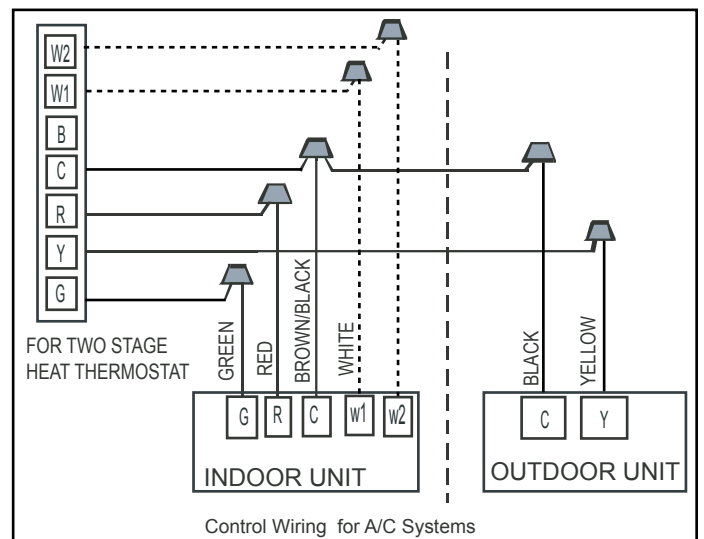
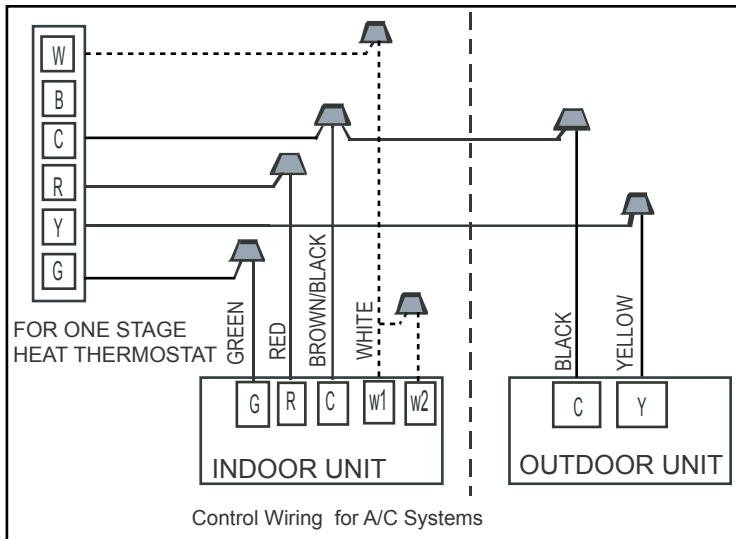

**Notes:**

1. Be sure power supply agrees with equipment nameplate.
2. Power wiring and grounding of equipment must comply with local codes.
3. Low voltage wiring to be No. 18 AWG minimum conductor.
4. "-----"The electric auxiliary heat connection(option).
5. W:Electric auxiliary heat signal.
6. W1 :The first Electric auxiliary heat signal.
7. W2 :The second Electric auxiliary heat signal.

Support 2H thermostat

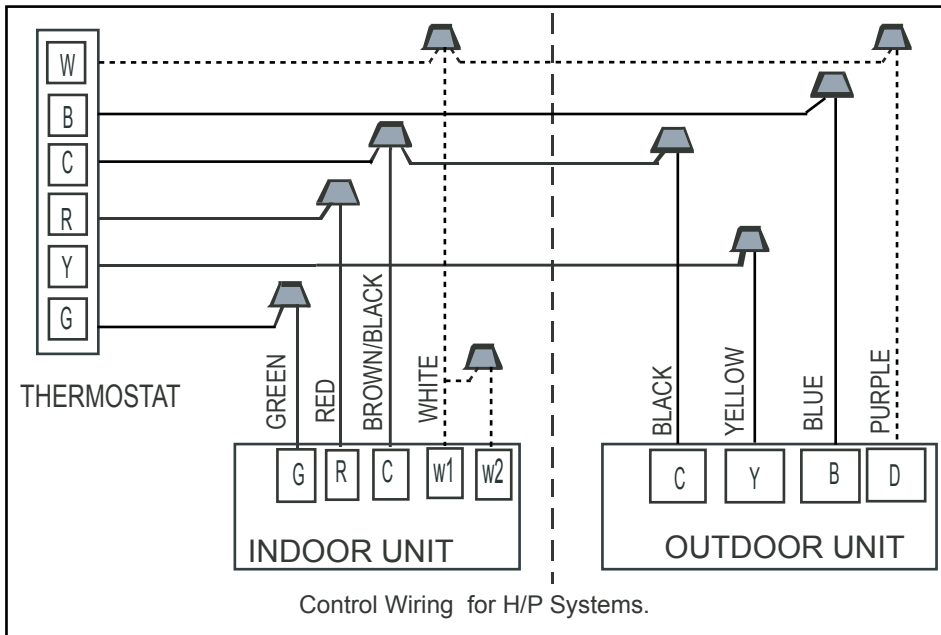

Support 3H thermostat

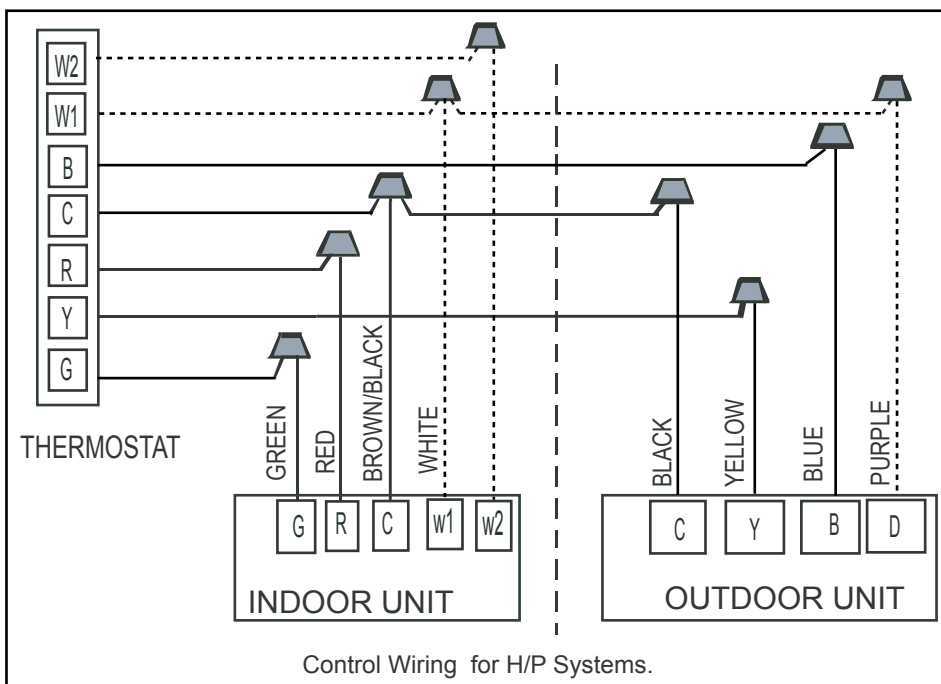

Notes:

1. Be sure power supply agrees with equipment nameplate.
2. Power wiring and grounding of equipment must comply with local codes.
3. Low voltage wiring to be No. 18 AWG minimum conductor.
4. "-----"The electric auxiliary heat connection(option).
5. W:Electric auxiliary heat signal.
6. W1 :The first Electric auxiliary heat signal.
7. W2 :The second Electric auxiliary heat signal.
8. The outdoornit D signal is connect to the Electric auxiliary heat or The first Electric auxiliary heat.

## Section 12. Electrical - High Voltage

### 12.1 High Voltage Power Supply

#### **⚠ WARNING**

##### **LIVE ELECTRICAL COMPONENTS!**

Check the power supply before installation. Ensure that the power supply must be reliably grounded following local, state and National Electrical Codes. If not, for example, if the ground wire is detected charged, installation is prohibited before it is rectified. Otherwise, there is a risk of fire and electric shock, causing physical injury or death.

#### **⚠ WARNING**

##### **LIVE ELECTRICAL COMPONENTS!**

During installation, testing, servicing, and troubleshooting of this product, it may be necessary to work with live electrical components. Failure to follow all electrical safety precautions when exposed to live electrical components could result in death or serious injury.

The high voltage power supply must agree with the equipment nameplate.

Power wiring must comply with national, state, and local codes.

Follow instructions on unit wiring diagram located on the inside of the control box cover and in the Service Facts document included with the unit.

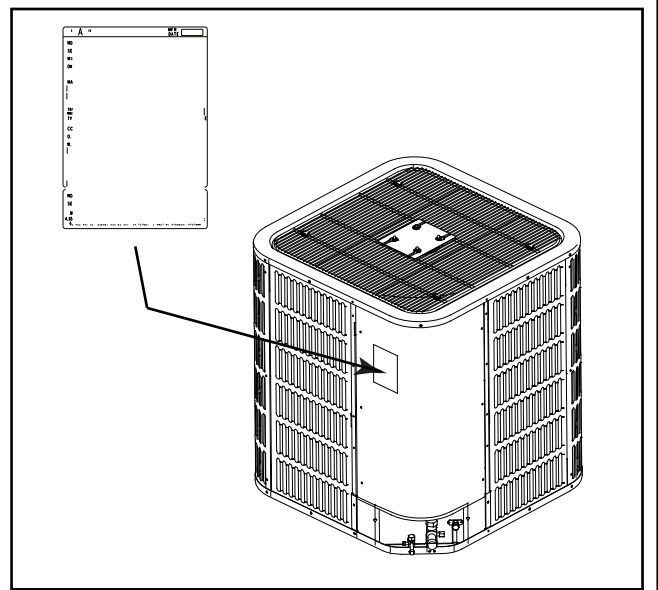

### 12.2 High Voltage Disconnect Switch

Install a separate disconnect switch at the outdoor unit.

Field provided flexible electrical conduit must be used for high voltage wiring.

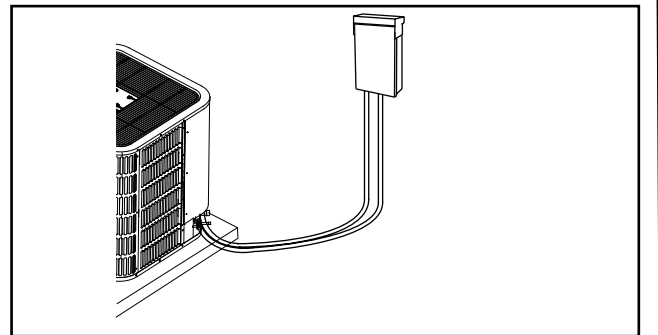

### 12.3 High Voltage Ground

Ground the outdoor unit per national, state, and local code requirements.

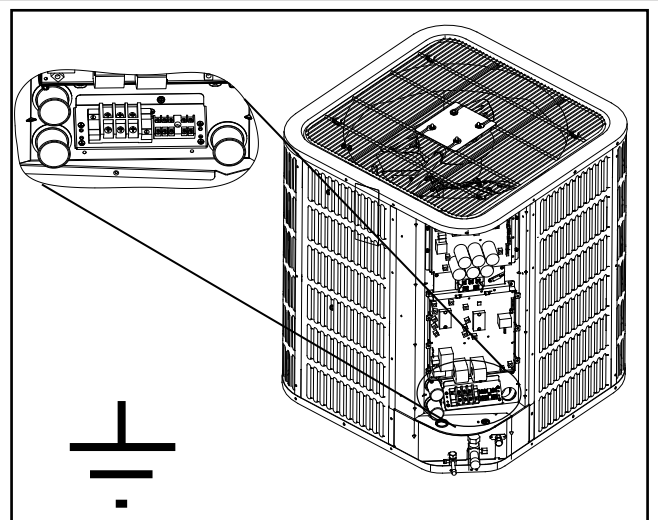

## Section 13. Start Up

### 13.1 System Start Up

**STEP 1** - Ensure Sections 7, 8, 9, 10, 11, 12, and 13 have been completed.

**STEP 2** - Set System Thermostat to OFF.

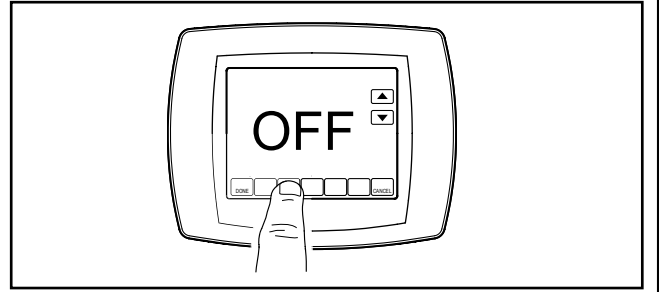

**STEP 3** - Turn on disconnect to apply power to the indoor and outdoor units.

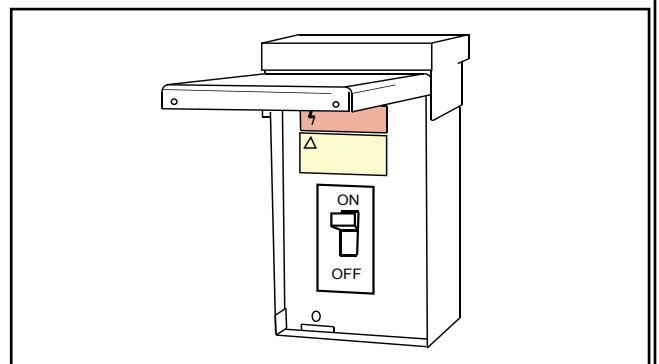

**STEP 4** - Wait five (5) minutes before moving to Step 5 if no crankcase heater accessory is used,

Wait one (1) hour before starting the unit if compressor crankcase heater accessory is used and the Outdoor Ambient Temperature is below 70 °F.

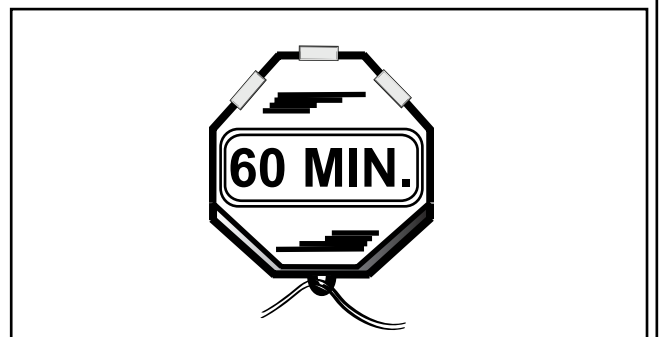

**STEP 5** - Set system thermostat to ON.

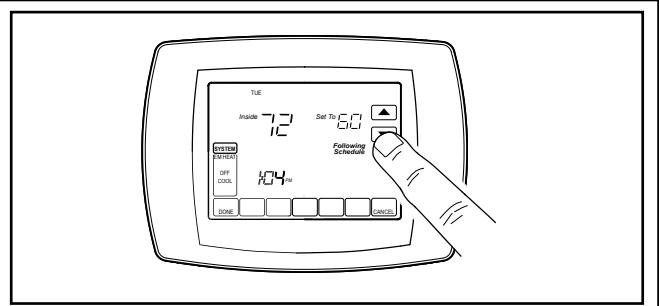

## Section 14. System Charge Adjustment

### 14.1 charging: weigh-In Method

Weigh-In Method can be used for the Initial installation, or anytime a system charge is being replaced. weigh-In Method can also be used when power is not available to the equipment site or operating conditions (indoor/Outdoor temperatures) are not In range to verify with the subcooling charging method.

A	B	C
Model	Factory Charge	charge multiplier for interconnecting refrigerant tube length
All models	(The data on nameplate)	0.6 oz/ft

Note: The factory charge in the outdoor unit is sufficient for 15 feet of standard size interconnecting liquid line.

Table 19. New Installations — Calculating additional charge for lineset greater than 15ft

1. Total Line Length (ft) = \_\_\_\_\_(a)
2. Standard Lineset (ft) = 15 (b)
3. (a) minus (b) = \_\_\_\_\_(c)
4. Refrigerant Multiplier = 0.6 oz/ft (d)
5. Refrigerant Adder (c\*d) = \_\_\_\_\_(e)\*

\*If lineset is less than 15 ft, (e) = 0

Table 20. Sealed-System Repairs — calculating charge using the weigh-In method.

1. Total Line Length (ft) = \_\_\_\_\_(a)
2. Standard Lineset (ft) = 15 (b)
3. (a) minus (b) = \_\_\_\_\_(c)
4. Refrigerant Multiplier = 0.6 oz/ft (d)
5. Refrigerant Adder (c\*d) = \_\_\_\_\_(e)\*
6. Factory Charge (nameplate) = \_\_\_\_\_(f)
7. Total System Charge (e+f) = \_\_\_\_\_

\*If lineset is less than 15 ft, (e) = 0

Note: The only mode approved for validating system charge is while in Cooling "Charge Mode". Outdoor Temperature must be between 55°F and 120°F with Indoor Temperature kept between 70°F and 80°F.



## 14.2 Subcooling charging and refrigerant adjustment in cooling (above 55 °F outdoor temp.)

### STEP 1 - Check the outdoor ambient temperatures.

Subcooling (in cooling mode) is the only recommended method of charging above 55°F outdoor ambient temperatures.

Outdoor Temperature Above 55°F

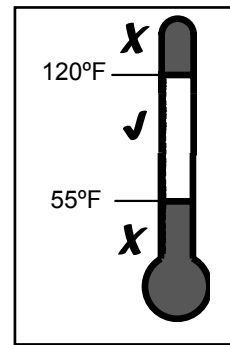

Outdoor Temp1

For outdoor ambient temperatures below 55°F, use weigh-in charge method.

Note: It is important to return in the spring or summer to accurately charge the system in the cooling mode when outdoor ambient temperature is above 55°F.

Outdoor Temperature Below 55°F

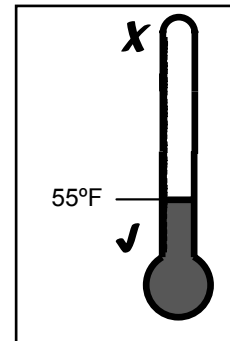

Outdoor Temp2

For best results the indoor temperature should be kept between 70°F to 80°F.

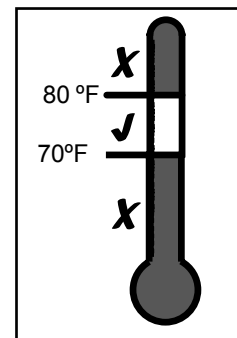

Indoor Temp

### STEP 2 - Ensure Sections 7, 8, 9, 10, and 13 have been completed.

### STEP 3 - Stabilize the system.

After starting the system in cooling mode, short press "FORCE" button, and "┐" symbol appears in 10 minutes, operate the system for a minimum of twenty (20) minutes.

**Important:** After twenty (20) minutes stabilization period, maintain continuous operation while adjusting refrigerant charge or TXV, after which operate system for a minimum of five (5) minutes for system to stabilize, otherwise repeat step 3.3.



**STEP 4 - Calculate superheat value on suction valves(According to form )**

Measured Suction Line Temp. = \_\_\_\_\_ °F  
 Measured Suction Line Pressure = \_\_\_\_\_ PSIG  
 Calculate superheat value = \_\_\_\_\_ °F

Note: Make sure the superheat value of suction valve should be above 12°F, if the value is lower than this, indoor TXV should be adjusted. If the temperature is higher than 18°F, we suggest to adjust indoor TXV.

Repeat the steps above.

(If to adjust TXV, steps of adjustment are shown on separate sheet, and repeat this step.)

If the TXV is not adjustable, make sure it works at all times.

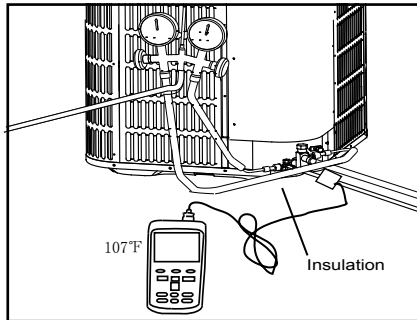

R-410A REFRIGERAN CHART								
SUCTION TEMP (°F)	FINAL SUPERHEAT(°F)							
	8	10	12	14	16	18	20	22
	SUCTION GAGE PRESSURE (PSI)							
40	101	97	93	89	86	82	78	75
42	105	101	97	93	89	86	82	78
44	110	105	101	97	93	89	86	82
46	114	110	105	101	97	93	89	86
48	118	114	110	105	101	97	93	89
50	123	118	114	110	105	101	97	93
52	128	123	118	114	110	105	101	97
54	133	128	123	118	114	110	105	101
56	138	133	128	123	118	114	110	105
58	143	138	133	128	123	118	114	110
60	148	143	138	133	128	123	118	114
62	153	148	143	138	133	128	123	118
64	159	153	148	143	138	133	128	123
66	164	159	153	148	143	138	133	128
68	170	164	159	153	148	143	138	133
70	176	170	164	159	153	148	143	138
72	182	176	170	164	159	153	148	143

**STEP 5 - Calculate subcooling value on liquid valves(According to form )**

Measured liquid Line Temp = \_\_\_\_\_ °F  
 Measured liquid Line Pressure = \_\_\_\_\_ PSIG  
 Calculate subcooling value = \_\_\_\_\_ °F

Note: If the subcooling value is lower than the design value, please add refrigerant when the superheat on suction meets the requirement.

Repeat the steps above.

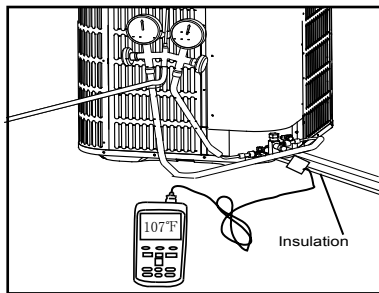

R-410A REFRIGERAN CHART									
LIQUID TEMP (°F)	FINAL SUBCOOLING (°F)								
	6	7	8	9	10	11	12	13	
	LIQUID GAGE PRESSURE (PSI)								
55	173	176	179	182	185	188	191	195	
60	188	191	195	198	201	204	208	211	
65	204	208	211	215	218	221	225	229	
70	221	225	229	232	236	239	243	247	
75	239	243	247	251	255	259	262	266	
80	259	262	266	270	275	279	283	287	
85	279	283	287	291	295	300	304	309	
90	300	304	309	313	318	322	327	331	
95	322	327	331	336	341	346	351	355	
100	346	351	355	360	365	370	376	381	
105	370	376	381	386	391	397	402	407	
110	397	402	407	413	418	424	430	435	
115	424	430	435	441	447	453	459	465	
120	453	459	465	471	477	483	489	496	
125	483	489	496	502	508	515	521	528	

Model	24	36	48	60
Design subcooling	10°F± 2°F	10°F± 2°F	8°F± 2°F	7°F± 2°F

**STEP 6** - Adjust refrigerant level to attain proper gage pressure.

**Add refrigerant** if the design subcooling is lower than the chart value.

1. Connect gages to refrigerant bottle and unit as illustrated.
2. Purge all hoses.
3. Open bottle.
4. Stop adding refrigerant when subcooling matches the charging chart Final Subcooling value.

**Recover refrigerant** if the subcooling is higher than the chart value.

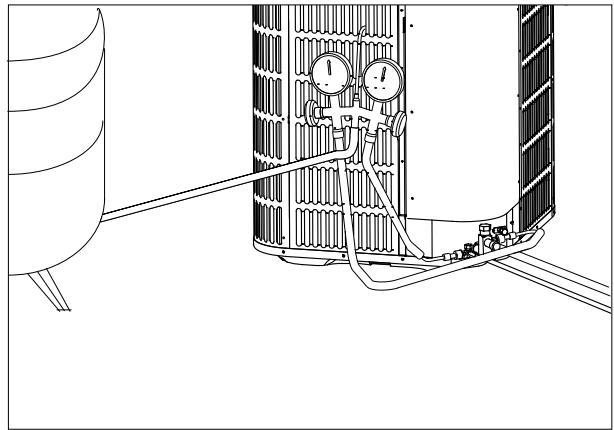

**STEP 7** - Stabilize the system.

1. Wait 5 minutes for the system condition to stabilize between adjustments.

**Note:** When the subcooling match the chart, the system is properly charged.

2. Remove gages.
3. Replace service port caps to prevent leaks.  
Tighten finger tight plus an additional 1/6 turn.



**STEP 8** - Record System Information for reference.

Record system pressures and temperatures after charging is complete.

Outdoor model number = \_\_\_\_\_

Measured Outdoor Ambient = \_\_\_\_\_ °F

Measured Indoor Ambient = \_\_\_\_\_ °F

Measured Liquid Line Temp = \_\_\_\_\_ °F

Measured Suction Line Temp = \_\_\_\_\_ °F

Liquid Gage Pressure = \_\_\_\_\_ PSIG

Suction Gage Pressure = \_\_\_\_\_ PSIG

## Section 15 System operation and Troubleshooting

### 1. Control logic description

- The variable speed system adopts the same 24VAC control as any conventional Heat Pump.
- The compressor's speed is controlled based on coil pressures monitored by pressure transducer. To insure stable and adequate capacity, the compressor speed will modulate relative to evaporator pressure during cooling operation and relative to condensing pressure during heating operation. The target pressure can auto-matically adjust based on compressor operation so optimal capacity can be achieved. Target pressure can manually be adjusted (SW4) to achieve improved dehumidification and capacity demands.

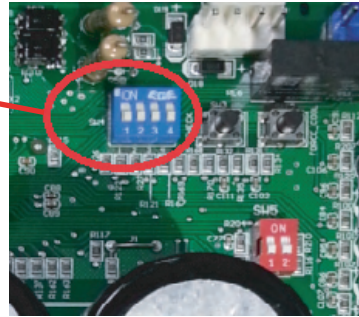
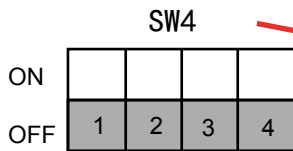

SW4-1	Not used	
SW4-2	Not used	
SW4-3	ON	Adaptive capacity output disable
	OFF	Adaptive capacity output enable
SW4-4	ON	Accelerated cooling/heating
	OFF	Normally cooling/heating

### 2. Sensor

- T3(Outdoor coil temperature) and T4(ambient temperature, heat pump only) see TABLE A
- T5(compressor discharge temperature) and Tf(IPM radiator temperature) see TABLE B.
- Pressure Transducer see TABLE C.

### 3. Sensor description

A working T3 Sensor is required for:

- Operating protection (high temp./low temp.)
- Outdoor fan control(cooling)
- Defrost (heat pump only)
- Ambient temp forecast (Cooling only)

A working T4 Sensor is required for(Heat pump only):

- Operating condition permission
- Defrosting condition permission
- Outdoor fan control(heating mode, Heat pump only)

A working T5 Sensor is required for:

- Protection(high temp./low temp.)
- Outside Electronic Expansion Valve control (Heat pump only)

A working Tf Sensor is required for:

- Module temp. protection(high temp.)

A working Pressure Transducer (PT) is required for:

- Operating speed control
- Outside Electronic Expansion Valve control (Heat pump only)
- High pressure protection(heating mode, Heat pump only)
- Low pressure protection(cooling mode)

#### 4、 Defrost description (Heat Pump only)

- The demand defrost control measures the coil temperature with a sensor located on the heat pump coil. A second sensor located outside the outdoor coil is used to measure outdoor ambient temperature.

The demand of defrost is computed by the coil temperature and outdoor ambient temperature ,also , by the running time and outdoor ambient temperature, by the running time and high pressure when hing pressure is lower than a certain value.

- Enter defrosting

Any one of three conditions is required to enter defrost:

1. The calculated temperature difference between the outdoor temperature(T4) and the coil temperature(T3) is called Delta T. After Delta T is achieved and lasted for 5 minutes.

- T4≥39°F, Delta T=18°F

- T4≥30°F, Delta T=16°F

- T4≥19°F, Delta T=14°F

- When T4 < 19°F, T3 < 9 °F, accumulative compressor run time ≥ 80 minutes.

2. After “Minimum Run Time” (MRT) is achieved. MRT is based on outdoor ambient temperature (T4), for example:

- MRT is 4 hours when: T4 < 23°F

- MRT is 2 hours when: 23°F ≤ T4 < 42°F

3. After the high pressure saturation temperature drops below 82°F for 20 minutes.

- Quit defrosting

1. Defrost will terminate once outdoor coil temperature (T3) reaches 64°F for a period of 1 minute or defrost time has exceeded 8 minutes.

2. Defrost Termination Settings (SW5) offers different defrost termination options for enhanced defrost for different geographical &/or outdoor conditions.

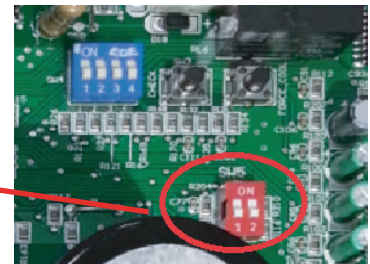
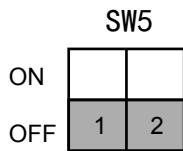

Defrosting choice	SW5-1	SW5-2	Remarks
ON	Operating time is reduced by 10%	Defrosting extended for 60 seconds	
OFF	Normal	Normal	Default
Remarks	Enter defrost	Quit defrost	

- Manual defrosting (Heat Pump only)

1. System must have a call for heat and have been operating for a minimum of 8 minutes.

2. Press “Force” button on inverter board for 6 seconds to begin forced defrost.

3. Wait approximately 40 seconds for defrost to initiate.

4. Once defrost initiates, the display will indicate “dF”.

5. Defrost test will terminate automatically, after which the display will indicate running speed.

6. If a second defrost test is required, repeat step 3 after 5 minutes.

## 5. Compressor Crankcase heater description

Refrigerant migration during the OFF cycle can result in a noisy start up, therefore a crankcase heater (CCH) is used to minimize refrigerant migration thereby minimizing start-up noise and/or bearing "wash out".

All CCHs must be installed on the lower half of the compressor shell. Its purpose is to warm the compressor on the OFF cycle, driving refrigerant from compressor. At initial start-up or after extended shutdown periods, allow CCH to be energized for at least 12 hours prior to compressor operation by applying line voltage to heat pump with thermostat OFF.

- CCH operation energizes:
  1. First time line voltage is applied and compressor discharge temperature  $T5 < 104^{\circ}\text{F}$ .
  2. In process of defrosting.
  3. Compressor stops running for 4 hours and outdoor ambient temperature  $T4 < 50^{\circ}\text{F}$  or  $T5 < 104^{\circ}\text{F}$ .
- CCH operation de-energizes:
  1. Compressor discharge temperature  $T5 \geq 113^{\circ}\text{F}$ .

## 6. Reversing valve introduction (heat pump only)

- Reversing valve energizes at the heating conditions, and cut off at the cooling condition.

## 7. Protection function introduction

- Outdoor coil temperature protection (T3)
  - i. If  $T3 > 143.6^{\circ}\text{F}$ , compressor is de-energized
  - ii. If  $T3 < 129.2^{\circ}\text{F}$ , compressor is energized
- Ambient temperature protection (T4)
  - i. If  $40^{\circ}\text{F} \leq T4 < 120^{\circ}\text{F}$ , unit can operate in cooling
  - ii. If  $5^{\circ}\text{F} \leq T4 < 86^{\circ}\text{F}$ , unit can operate in heating
  - iii. If  $T4 < 6.8^{\circ}\text{F}$ , heat pump will provide 24V control to indoor unit energizing electric heat (if installed).
- Discharge Temperature (DT) protection (T5)
  - i. If  $DT > 239^{\circ}\text{F}$  during cooling mode, the compressor will stop.
  - ii. If  $DT < 194^{\circ}\text{F}$  during cooling mode, the compressor will restart.
  - iii. If  $DT > 221^{\circ}\text{F}$  during heating mode, the compressor will stop.
  - iv. If  $DT < 167^{\circ}\text{F}$  during heating mode, the compressor will restart.
- High pressure protection (HPS) (mechanical open/close pressure switch)
  - i. HPS opens at  $P > 580$  PSIG, the compressor and outdoor fan stop.
  - ii. HPS closes at  $P < 435$  PSIG, the compressor and outdoor fan restart.
- Low pressure protection (LP)
  - i. If Low Pressure  $< 43.5$  PSI for 5 minutes during cooling mode, the compressor and outdoor fan will stop. System will attempt to run again after 6 minutes.
- Module (inverter) protection (TF)
  - i. If  $TF > 176^{\circ}\text{F}$ , the compressor and outdoor fan will stop.
  - ii. If  $TF < 145^{\circ}\text{F}$ , the compressor and outdoor fan will restart.

Note: In keeping with product improvement, we reserve the right to make changes without notice.

## 8. Fault code table

Code	Fault Description
E4	Temperature sensor fault(T3, T4, T5, TF)
E5	High/low voltage protection
E6	DC fan motor fault
E7	Compressor discharge sensor(T5) is seated fault
E9	EEPROM fault
Eb	System lockup, 2 times (E6) protection in 10 minutes
H0	Communication fault in main control chip
H4	System lockup, 3 times (P6) protection in 60 minutes
H5	System lockup, 5 times (P2) protection in 100 minutes
H8	Pressure transducer(PT) fault
Hb	High pressure(PT) protection in Heating
P0	High module radiator temperature (TF)protection
P1	High pressure switch(HPS)protection
P2	Low pressure(PT) Protection in cooling
P3	Compressor over current protection
P4	High compressor discharge temperature(T5) protection
P5	Condensor coil temperature(T3) protection in cooling
P6	The IPM module protection
PH	Low discharge superheat protection
F1	High pressure switch(HPS) fault
C3	The condensor coil sensor(T3) is seated fault in cooling
L0-L9	The IPM module protection (the same as P6,only for analysis)
AtL	Ambient Temperature Limited
System Protection Status Codes	
┆	Indication under charge model
L	Running indication under T3 limited condition
D	Running indication under T5 limited condition
P	Running indication under compressor ratio limited condition
F	Running indication under Tf limited condition
C	Running indication under current limited condition
U	Running indication under low voltage limited condition
H	Running indication under high pressure(PT) limited condition in heating
A	Running indication under return oil model
dF	Running indication under defrost model

## 9. Parameter point check table



1. To display system parameters, press the “Check” button to index through the series of parameters available. The first time you press on the “Check” button, it will display the sequence, and after 1 second it will display the value of the parameter. If you press the “Check” button again, it will display the next sequence.
2. Normal Status, last two digits will display under following conditions
  - i. Unit not operating(Standby Mode); “outdoor ambient temperature”.
  - ii. Unit operating; displays “compressor operating frequency”.
3. After 20 seconds on same parameter, display will revert back to normal status.
4. If a system protection is active, first digit will display “status code”.

No.	Point check content	Example	Remark
0	Outdoor unit capacity	H3	H3=Heat Pump 3 ton
1	Outdoor unit mode	2	0 standby, 2 cooling, 3 heating
2	Outdoor unit set compressor speed		
3	Opening of EEV		Actual value
4	T3(outdoor coil temp.) (°F )		
5	T4 (outdoor ambient temp.) (°F )		
6	T5(compressor discharge temp.) (°F )		
7	Reserved		
8	Te (evaporating temp.) (°F )		
9	Tc (condensing temp.) (°F )		
10	Tf (module temp.) (°F )		
11	Pe (evaporating pressure) (PSI)		
12	Pc (condensing pressure) (PSI)		
13	Compressor discharge superheat (°F )		Actual value
14	Reserved		
15	Reserved		
16	Compressor current (A)		
17	Reserved		
18	Fan speed		
19	Reserved		
20	Reserved		
21	Target of the compressor discharge superheat(only useful for heating mode)(°F)		Target Value
22	Reserved		
23	Last Fault Code		
24	Software version		
25	Remark“--”		

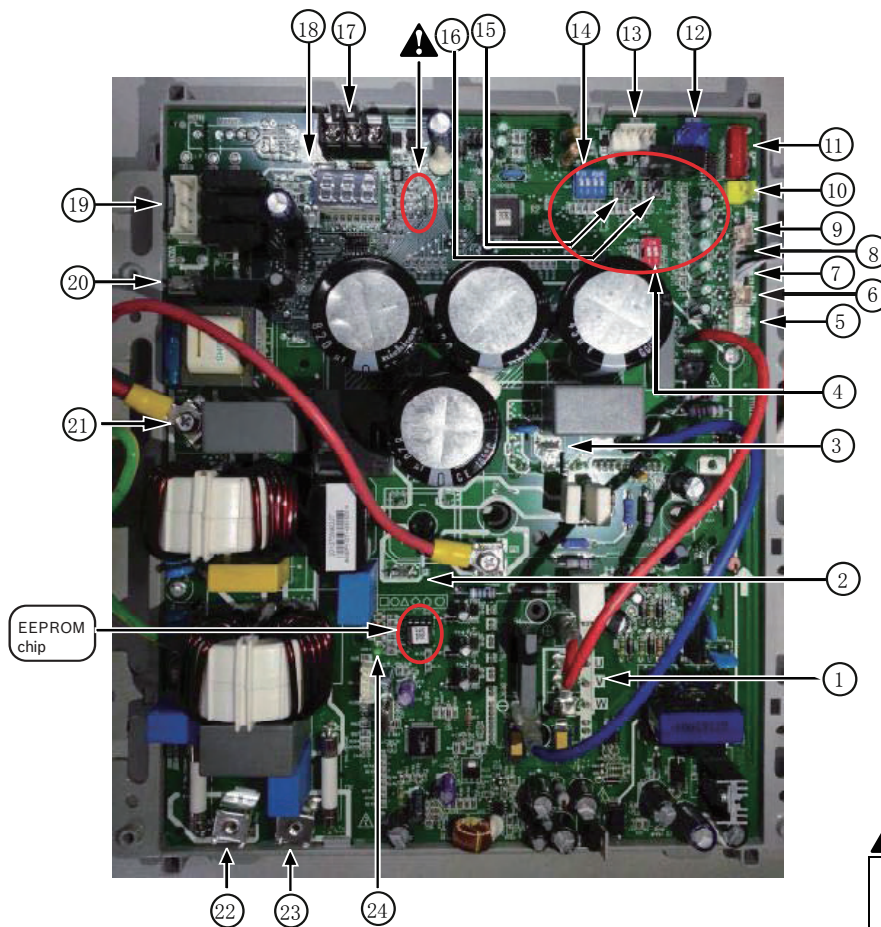

## For 24/36k model



⚠		
SWITCH	J2 	FOR 36K MODEL
	J2 	FOR 24K MODEL
JUMPER (OPTION)	J2 CONNECT	FOR 36K MODEL
	J2 CUT OFF	FOR 24K MODEL

NOTE: The photo is just for reference, actual unit will verify.

No.	Function description	No.	Function description
1	Compressor wiring terminal	13	Temp. controller connecting port
2	Reactor wiring terminal(connect a reactor between 2 and 3 )	14	Function dial code SW4
3	Reactor wiring terminal(connect a reactor between 2 and 3 )	15	Spot check button
4	Defrosting function dial code SW5	16	Forced operation button
5	Pressure transducer port	17	Reserved
6	Compressor discharge temp. sensor port	18	Digital tube display
7	Ambient temp. sensor port(HP only)	19	Fan control port
8	Outdoor coil temp. sensor port	20	Crankcase heating zone control terminal
9	Radiator temp. sensor port	21	Short wire
10	High pressure switch port	22	Power supply connecting terminal
11	EEV drive port(HP only)	23	Power supply connecting terminal
12	Reversing valve port(HP only)	24	Indicator lamp

# For 48/60k model

Main control board

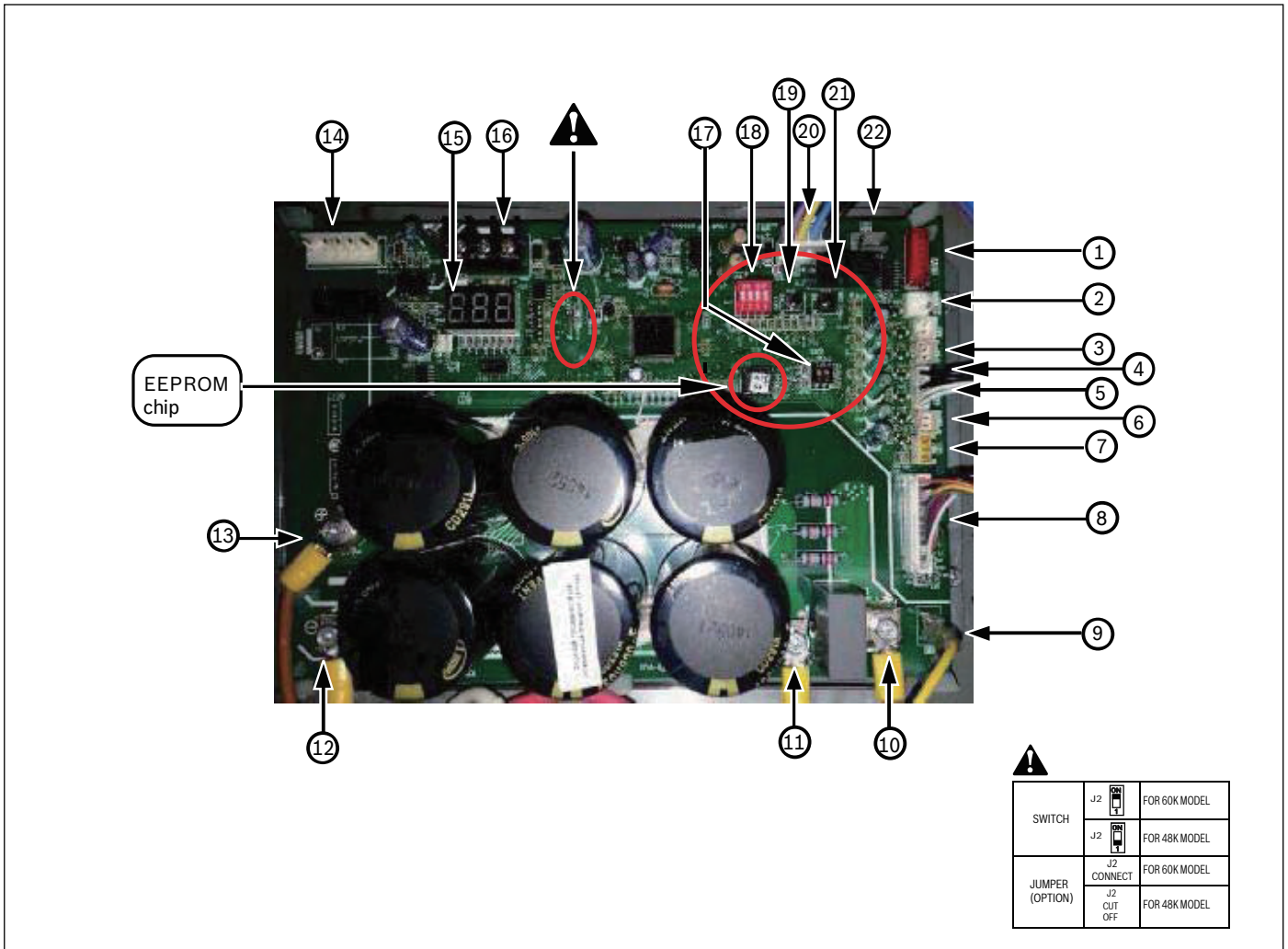

NOTE: The photo is just for reference, actual unit will verify.

No.	Function description	No.	Function description
1	EEV driving port (HP only)	12	The voltage between 12 and 13 is 380Vdc (Compressor is running )
2	High pressure switch port	13	The voltage between 12 and 13 is 380Vdc (Compressor is running )
3	Radiator temp. sensor port	14	DC motor control port
4	Outdoor coil temp. sensor port	15	Nixie tube display
5	Ambient temp. sensor port(HP only)	16	Reserved
6	Compressor discharge temp. sensor port	17	Defrosting functiondialcode SW5
7	Pressure transducer	18	Function dial code SW4
8	Connection wire port between main boards	19	Point check button
9	DC motor driving source (15V-P2)	20	Temp. controller connection port
10	The voltage between 10 and 11 is 380Vdc (Compressor is running )	21	Forced operation button
11	The voltage between 10 and 11 is 380Vdc (Compressor is running )	22	Reversing valve port(HP only)

Drive board

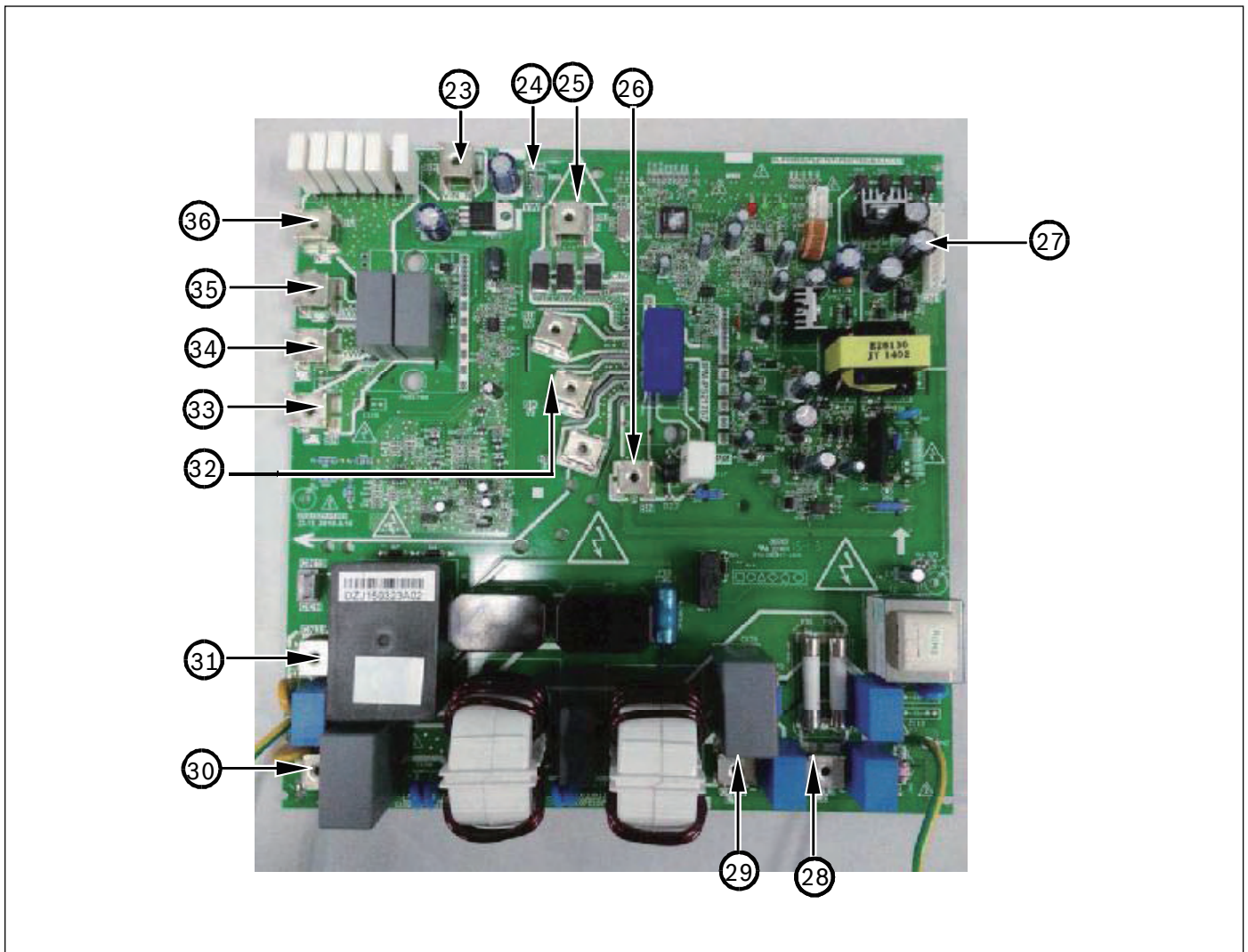

NOTE: The photo is just for reference, actual unit will verify.

No.	Function description	No.	Function description
23	Connect the cathode of the rectifier bridge	30	AC power supply output port
24	DC motor driving source(15V-P2)	31	AC power supply output port
25	The voltage between 25 and 26 is 380Vdc (Compressor is running )	32	Compressor connection terminal
26	The voltage between 25 and 26 is 380Vdc (Compressor is running )	33	The voltage between 33 and 36 is 380Vdc (Compressor is running )
27	Connection wire port between main boards	34	Reactor L1 wiring terminal
28	AC power supply input port	35	Reactor L2 wiring terminal
29	AC power supply input port	36	The voltage between 33 and 36 is 380Vdc (Compressor is running)

### 15.10 Error code troubleshooting

Error Code	Description
P1	High pressure switch(HPS)protection
P5	Condenser coil temperature(T3) protection in cooling
Hb	High pressure(PT) protection in Heating
P3	Compressor over current protection

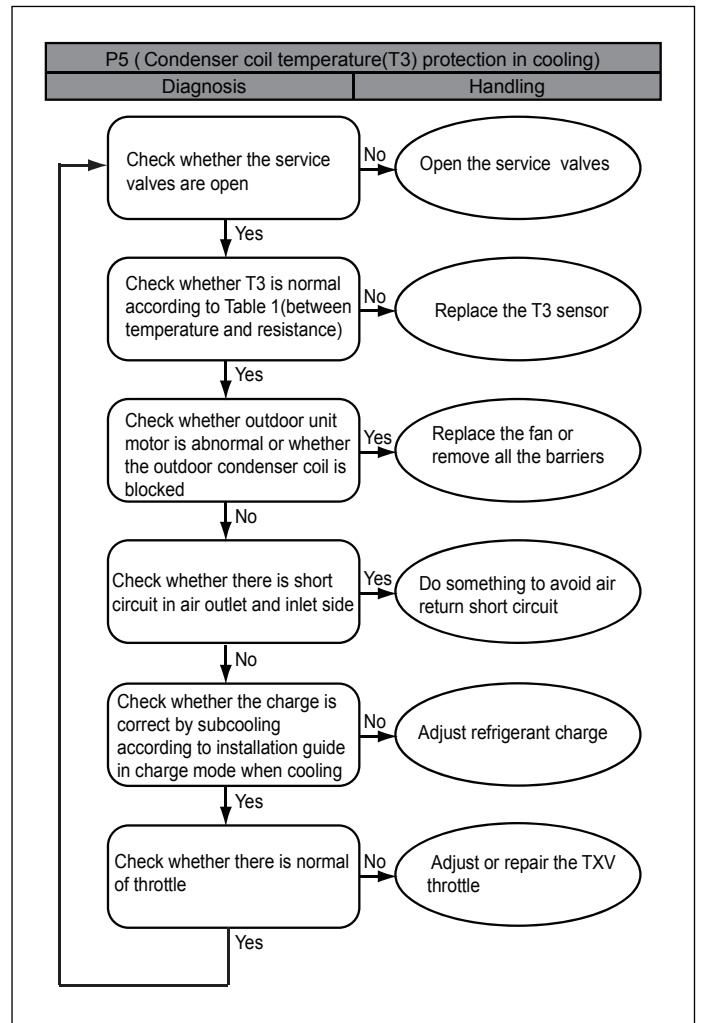
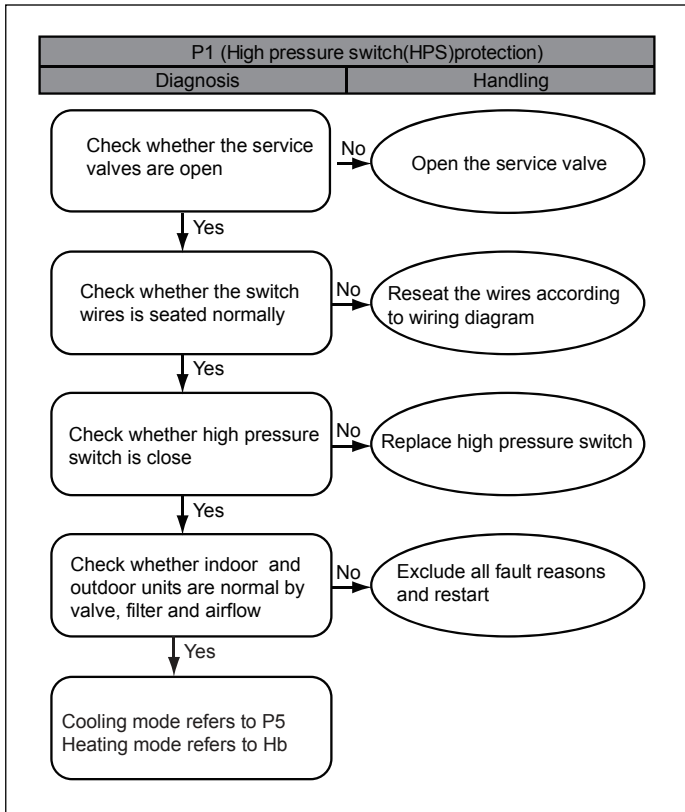

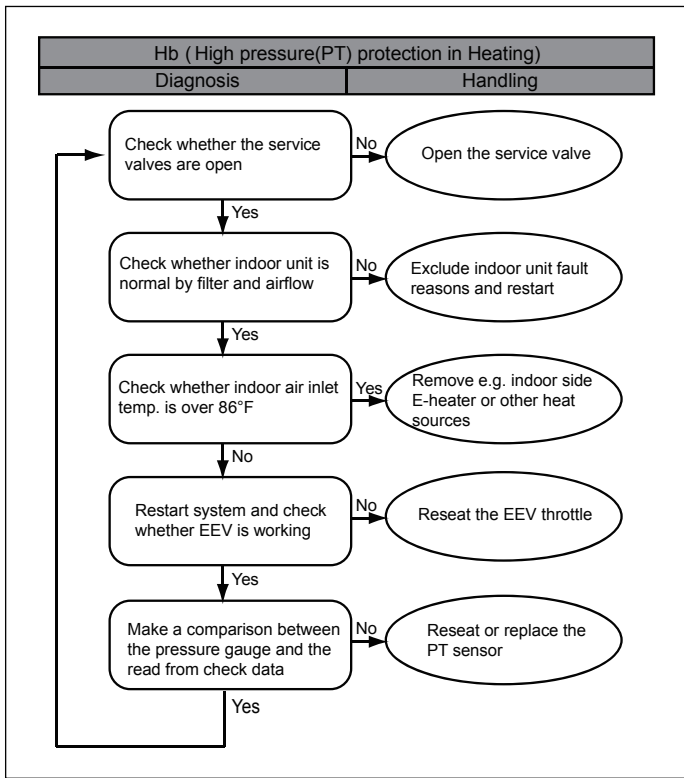

Error Code	Description
P0	High module radiator temperature (TF) protection

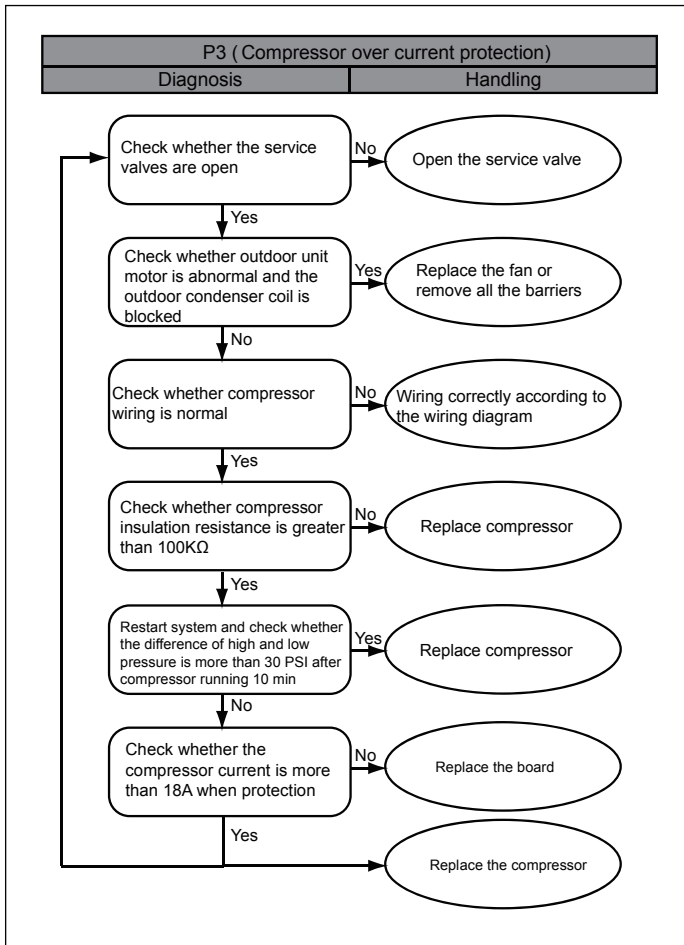
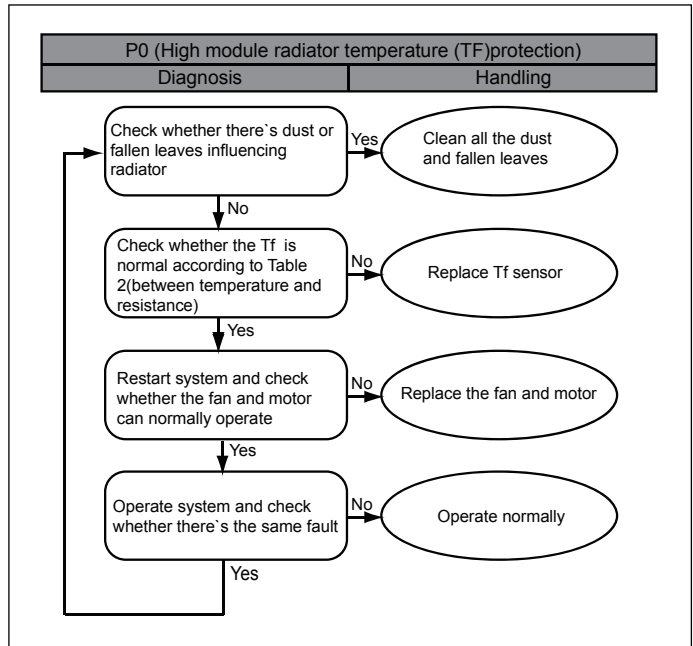

Error Code	Description
P2	Low pressure(PT) Protection in cooling
H5	System lockup, 5 times (P2) protection in 100 minutes
P4	High compressor discharge temperature(T5) protection

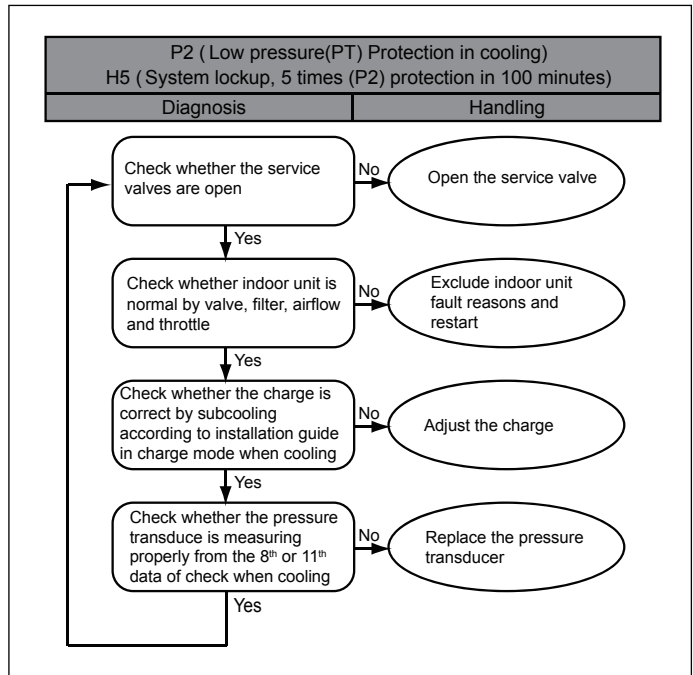

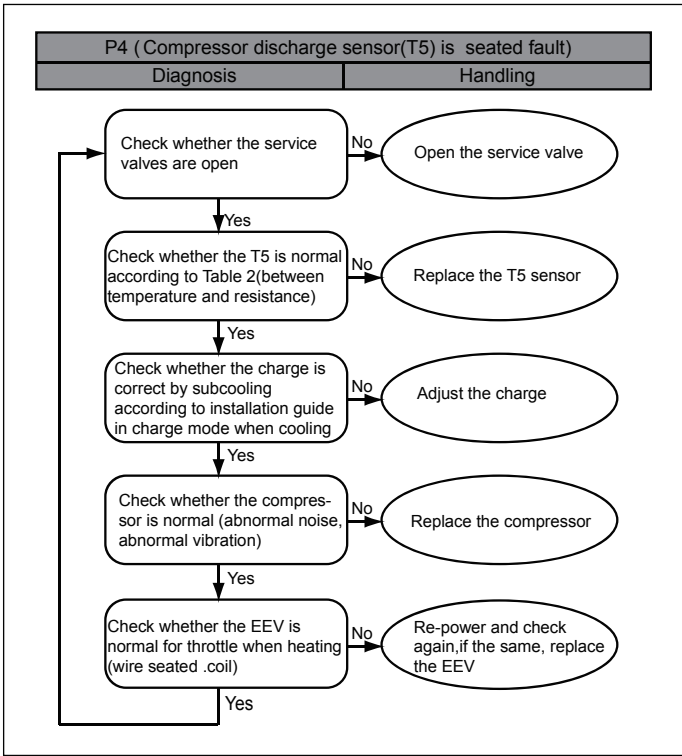

Error Code	Description
PH	Low discharge superheat protection

Error Code	Description
E4	Temperature sensor fault(T3, T4, T5, TF)
H8	Pressure transducer(PT) fault
F1	High pressure switch(HPS) fault

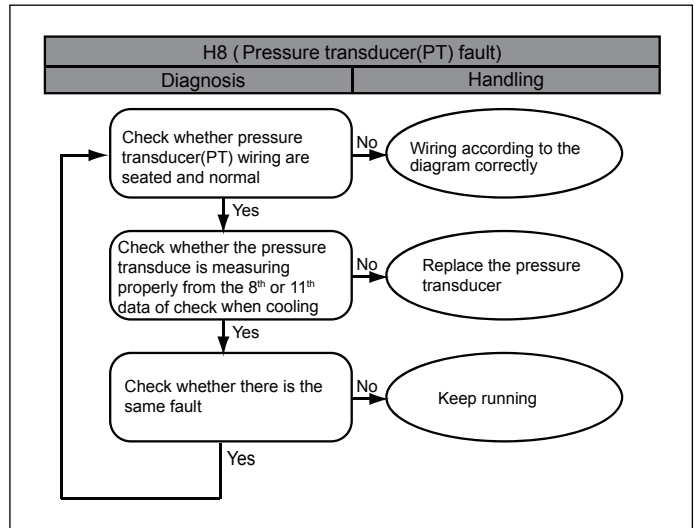
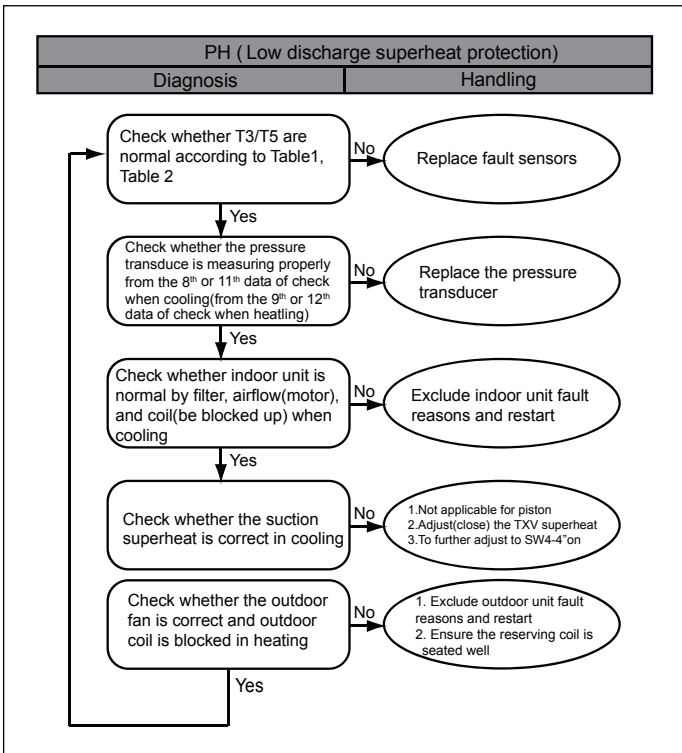
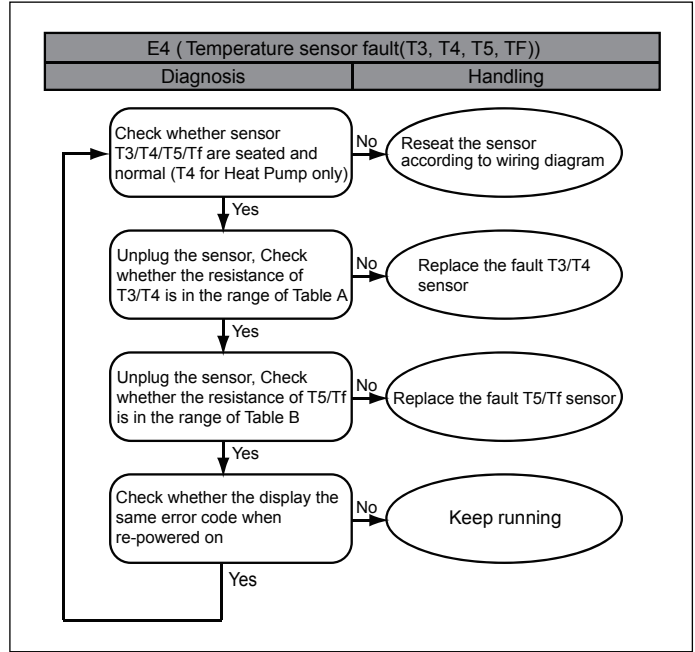

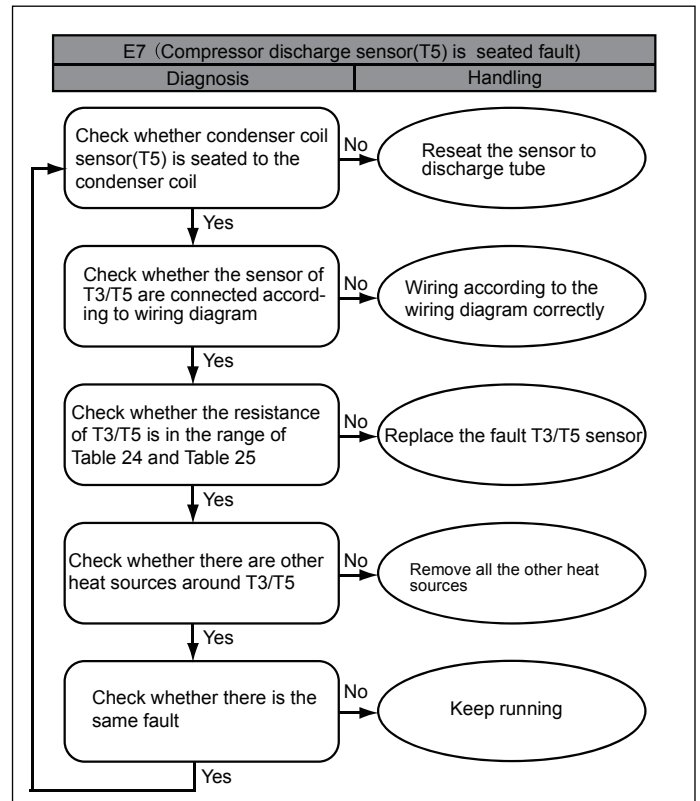
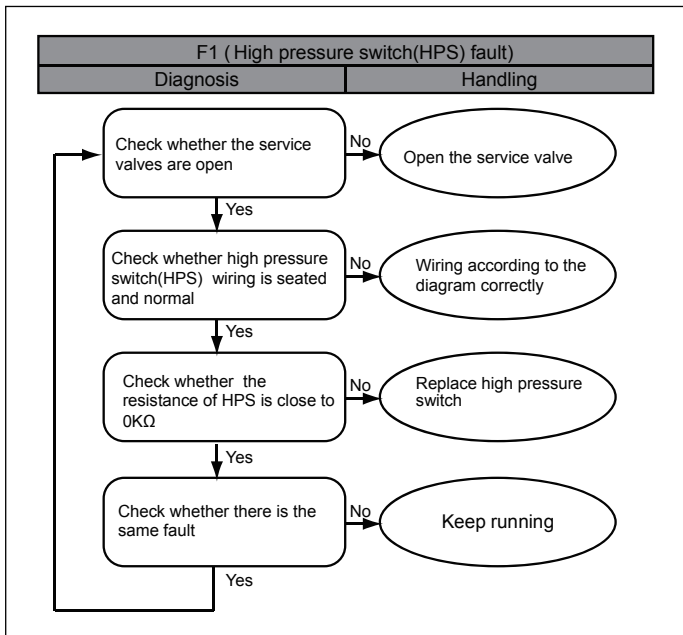

Error Code	Description
C3	Condenser coil sensor(T3) is seated fault in cooling
E7	Compressor discharge sensor(T5) is seated fault

Error Code	Description
E6	DC fan motor fault
Eb	System lockup, 2 times (E6) protection in 10 minutes

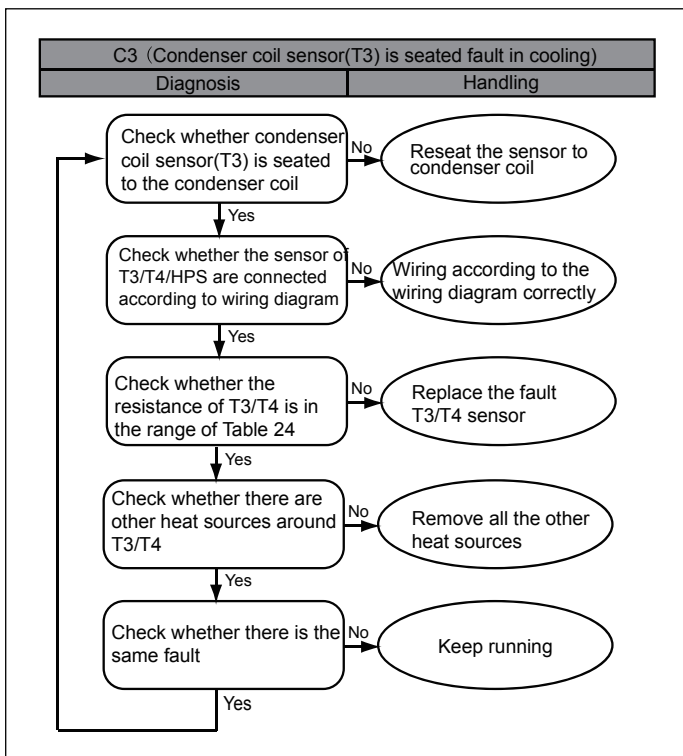

When E6 appears occasionally, you don't need to do anything, the system will restart automatically after 6 minutes, of course, if you check the system of running, it will be better. When Eb appears, you need to check the motor.

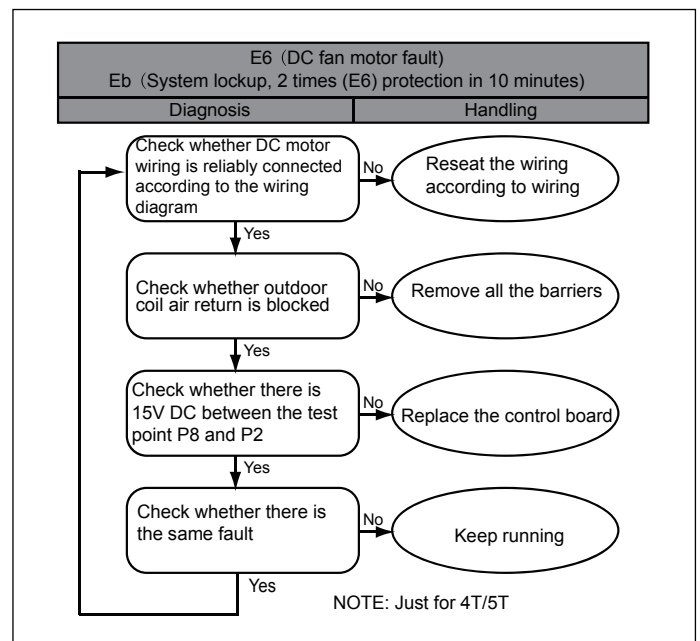

Error Code	Description
E9	EEPROM fault
H0	Communication fault in main control chip
E5	High/low voltage protection

When E9/H0/E5 appears occasionally, and the system restart to run normally after power supply again, you don't need to do anything. Otherwise, you need to check the system.

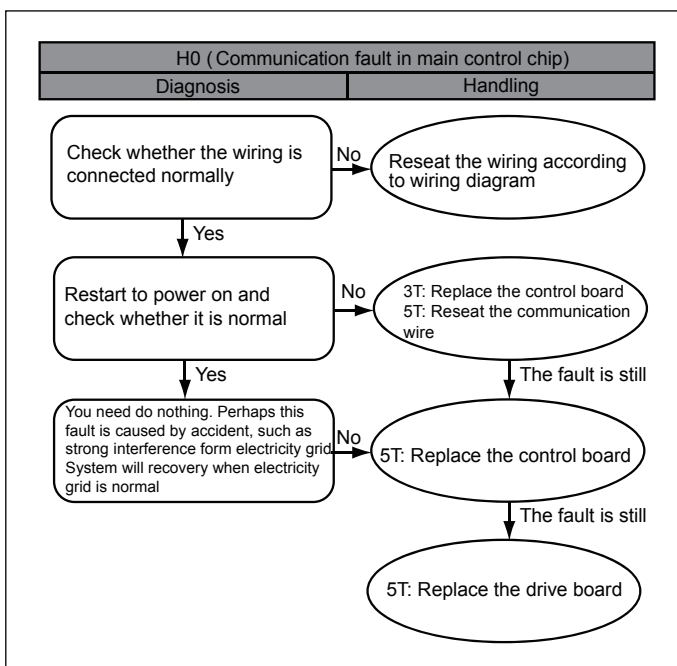
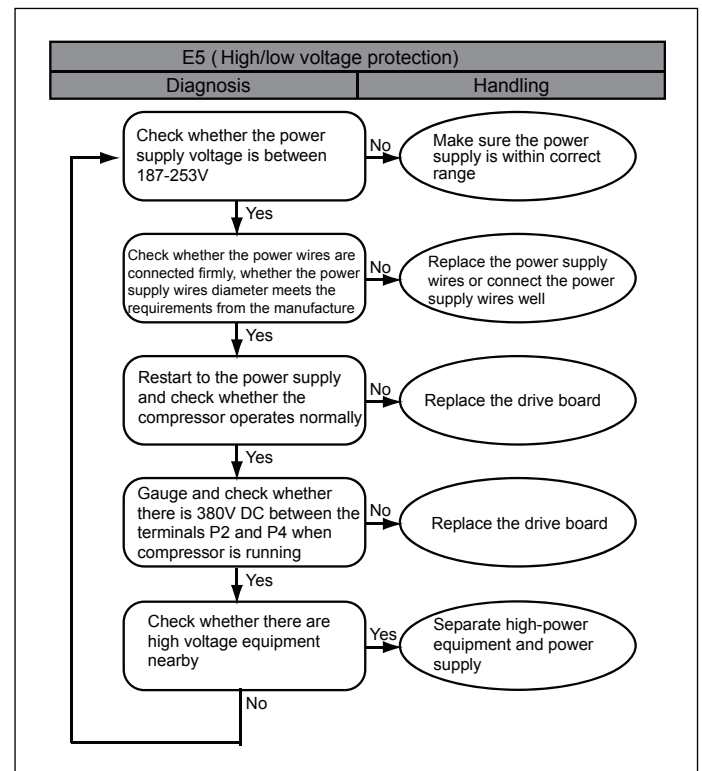
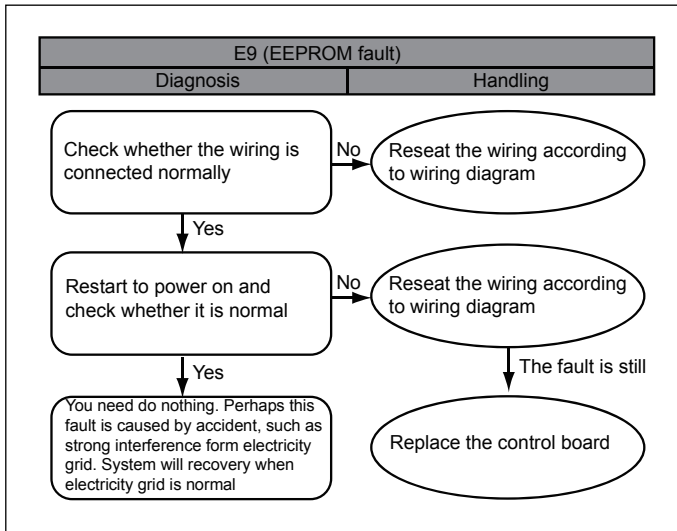



Error Code	Description
P6	IPM module protection
H4	System lockup, 3 times (P6/L0-9) protection in 60 minutes
L0-L9	IPM module protection (the same as P6, only for analysis)

When P6/L0-L9 appears occasionally, you don't need to do anything, the system will restart automatically after 6 minutes, of course, if you check the system of running, it will be better.

Error Code	Description
AtL	Ambient Temperature Limited

NOTE: When the ambient temperature returns to within the operating range, the system recovery automatically.

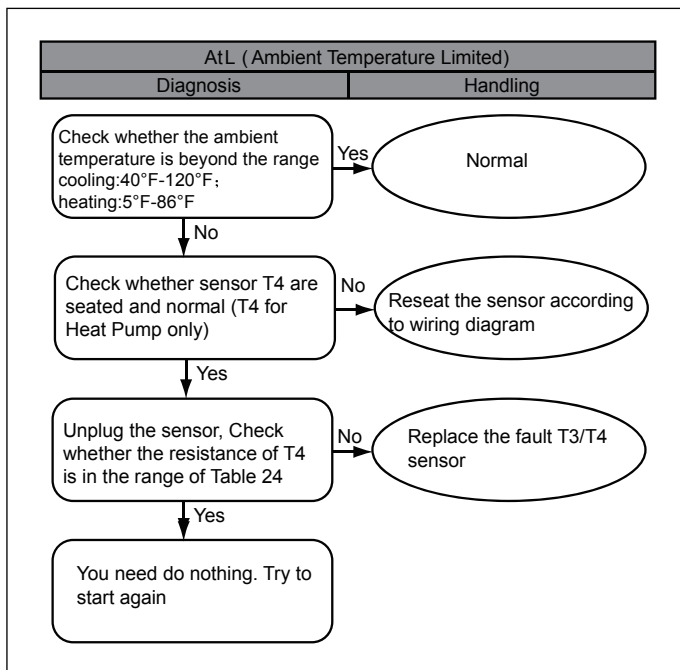
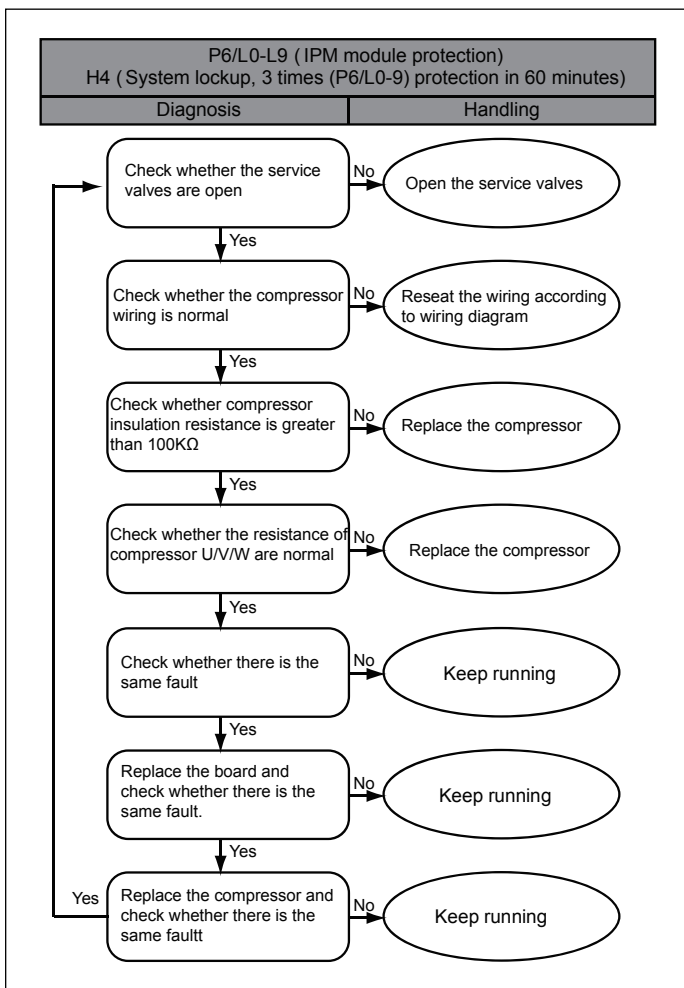

TABLE A

TEMP F	TEMP C	RESISTANCE kΩ	VOLTS DC	TEMP F	TEMP C	RESISTANCE kΩ	VOLTS DC
-5	-20.6	107.732	4.65	90	32.2	7.225	2.36
0	-17.8	93.535	4.6	95	35	6.401	2.21
5	-15	79.521	4.54	100	37.8	5.683	2.07
10	-12.2	67.795	4.47	105	40.6	5.057	1.93
15	-9.4	57.948	4.39	110	43.3	4.509	1.79
20	-6.7	49.652	4.3	115	46.1	4.028	1.67
25	-3.9	42.645	4.21	120	48.9	3.606	1.55
30	-1.1	36.710	4.1	125	51.7	3.233	1.43
40	4.4	27.386	3.86	130	54.4	2.902	1.32
45	7.2	23.732	3.73	135	57.2	2.610	1.22
50	10	20.610	3.59	140	60	2.350	1.13
55	12.8	17.939	3.45	145	62.8	2.119	1.04
60	15.6	15.648	3.3	150	65.6	1.914	0.96
65	18.3	13.681	3.15	155	68.3	1.731	0.88
70	21.1	11.987	2.99	160	71.1	1.574	0.82
75	23.9	10.527	2.83	165	73.9	1.416	0.75
80	26.7	9.265	2.67	170	76.7	1.276	0.68
85	29.4	8.172	2.52				

TABLE B

TEMP F	TEMP C	RESISTANCE kΩ	VOLTS DC	TEMP F	TEMP C	RESISTANCE kΩ	VOLTS DC
-5	-20.6	600.134	4.93	140	60	13.643	3.14
0	-17.8	505.551	4.92	145	62.8	12.359	3.03
5	-15	427.463	4.91	150	65.6	11.214	2.91
10	-12.2	362.739	4.89	155	68.3	10.227	2.8
15	-9.4	308.891	4.87	160	71.1	9.308	2.68
20	-6.7	265.398	4.85	165	73.9	8.485	2.56
25	-3.9	227.481	4.83	170	76.7	7.746	2.45
30	-1.1	195.601	4.8	175	79.4	7.105	2.34
35	1.7	168.707	4.77	180	82.2	6.504	2.23
40	4.4	146.695	4.74	185	85	5.963	2.13
45	7.2	127.258	4.7	190	87.8	5.474	2.02
50	10	110.707	4.66	195	90.6	5.032	1.92
55	12.8	96.572	4.61	200	93.3	4.645	1.83
60	15.6	84.465	4.56	205	96.1	4.28	1.73
65	18.3	74.411	4.51	210	98.9	3.949	1.64
70	21.1	65.408	4.45	215	101.7	3.648	1.56
75	23.9	57.634	4.39	220	104.4	3.383	1.48
80	26.7	50.904	4.32	225	107.2	3.133	1.4
85	29.4	45.258	4.24	230	110	2.904	1.32
90	32.2	40.152	4.16	235	112.8	2.694	1.25
95	35	35.699	4.08	240	115.6	2.503	1.18
100	37.8	31.807	3.99	245	118.3	2.334	1.12
105	40.6	28.398	3.89	250	121.1	2.172	1.06
110	43.3	25.506	3.8	255	123.9	2.024	1
115	46.1	22.861	3.7	260	126.7	1.888	0.95
120	48.9	20.529	3.59	265	129.4	1.767	0.9
125	51.7	18.47	3.48	270	132.2	1.651	0.85
130	54.4	16.708	3.37	275	135	1.544	0.8
135	57.2	15.085	3.26	280	137.8	1.446	0.76

TABLE C1 (For AC model)

NSK-BD020I $V=1.38*PSIG*10^{-2}+0.5$							
No.	V	Te	Pe	No.	V	Te	Pe
		°F	PSIG			°F	PSIG
1	1.04	-8	39	47	2.00	36	109
2	1.07	-6	41	48	2.02	37	111
3	1.10	-4	43	49	2.05	37	113
4	1.11	-3	44	50	2.08	38	115
5	1.13	-2	45	51	2.11	39	117
6	1.14	-1	47	52	2.14	40	119
7	1.16	0	48	53	2.16	41	121
8	1.17	1	49	54	2.19	42	123
9	1.19	1	50	55	2.22	43	125
10	1.21	2	51	56	2.25	44	127
11	1.22	3	52	57	2.28	45	129
12	1.24	4	54	58	2.31	46	131
13	1.26	5	55	59	2.34	46	134
14	1.27	6	56	60	2.37	47	136
15	1.29	7	57	61	2.40	48	138
16	1.31	8	59	62	2.44	49	140
17	1.33	9	60	63	2.47	50	143
18	1.35	10	61	64	2.50	51	145
19	1.37	10	63	65	2.53	52	147
20	1.38	11	64	66	2.56	53	150
21	1.40	12	66	67	2.60	54	152
22	1.42	13	67	68	2.63	55	155
23	1.44	14	68	69	2.67	55	157
24	1.46	15	70	70	2.70	56	160
25	1.48	16	71	71	2.74	57	162
26	1.50	17	73	72	2.77	58	165
27	1.52	18	74	73	2.81	59	167
28	1.54	19	76	74	2.84	60	170
29	1.57	19	77	75	2.88	61	172
30	1.59	20	79	76	2.92	62	175
31	1.61	21	80	77	2.95	63	178
32	1.63	22	82	78	2.99	64	181
33	1.65	23	84	79	3.03	64	183
34	1.68	24	85	80	3.07	65	186
35	1.70	25	87	81	3.10	66	189
36	1.72	26	89	82	3.14	67	192
37	1.75	27	90	83	3.18	68	195
38	1.77	28	92	84	3.22	69	197
39	1.79	28	94	85	3.26	70	200
40	1.82	29	96	86	3.30	71	203
41	1.84	30	97	87	3.35	72	206
42	1.87	31	99	88	3.39	73	209
43	1.89	32	101	89	3.43	73	212
44	1.92	33	103	90	3.47	74	216
45	1.94	34	105	91	3.51	75	219
46	1.97	35	107	92	3.56	76	222

TABLE C2 (For HP model)

NSK-BD035I				V=7.88*PSIG*10 <sup>-3</sup> +0.5							
No.	V	Te/Tc	Pe/Pc	No.	V	Te/Tc	Pe/Pc	No.	V	Te/Tc	Pe/Pc
		°F	PSIG			°F	PSIG			°F	PSIG
1	0.69	-22	24	56	1.37	37	111	111	2.54	86	258
2	0.70	-20	26	57	1.39	37	113	112	2.56	87	262
3	0.72	-18	28	58	1.40	38	115	113	2.59	88	266
4	0.73	-17	29	59	1.42	39	117	114	2.62	89	269
5	0.75	-15	31	60	1.43	40	119	115	2.65	90	273
6	0.76	-13	33	61	1.45	41	121	116	2.68	91	277
7	0.78	-11	35	62	1.47	42	123	117	2.71	91	280
8	0.79	-9	37	63	1.48	43	125	118	2.74	92	284
9	0.81	-8	39	64	1.50	44	127	119	2.77	93	288
10	0.82	-6	41	65	1.52	45	129	120	2.80	94	292
11	0.84	-4	43	66	1.53	46	131	121	2.83	95	295
12	0.85	-3	44	67	1.55	46	134	122	2.86	96	299
13	0.86	-2	45	68	1.57	47	136	123	2.89	97	303
14	0.87	-1	47	69	1.59	48	138	124	2.92	98	307
15	0.88	0	48	70	1.61	49	140	125	2.95	99	311
16	0.89	1	49	71	1.62	50	143	126	2.98	100	315
17	0.89	1	50	72	1.64	51	145	127	3.02	100	319
18	0.90	2	51	73	1.66	52	147	128	3.05	101	324
19	0.91	3	52	74	1.68	53	150	129	3.08	102	328
20	0.92	4	54	75	1.70	54	152	130	3.12	103	332
21	0.93	5	55	76	1.72	55	155	131	3.15	104	336
22	0.94	6	56	77	1.74	55	157	132	3.18	105	340
23	0.95	7	57	78	1.76	56	160	133	3.22	106	345
24	0.96	8	59	79	1.78	57	162	134	3.25	107	349
25	0.97	9	60	80	1.80	58	165	135	3.29	108	353
26	0.98	10	61	81	1.82	59	167	136	3.32	109	358
27	0.99	10	63	82	1.84	60	170	137	3.36	109	362
28	1.01	11	64	83	1.86	61	172	138	3.39	110	367
29	1.02	12	66	84	1.88	62	175	139	3.43	111	371
30	1.03	13	67	85	1.90	63	178	140	3.46	112	376
31	1.04	14	68	86	1.92	64	181	141	3.50	113	381
32	1.05	15	70	87	1.94	64	183	142	3.54	114	385
33	1.06	16	71	88	1.97	65	186	143	3.57	115	390
34	1.07	17	73	89	1.99	66	189	144	3.61	116	395
35	1.09	18	74	90	2.01	67	192	145	3.65	117	400
36	1.10	19	76	91	2.03	68	195	146	3.69	118	405
37	1.11	19	77	92	2.06	69	197	147	3.73	118	409
38	1.12	20	79	93	2.08	70	200	148	3.77	119	414
39	1.13	21	80	94	2.10	71	203	149	3.80	120	419
40	1.15	22	82	95	2.13	72	206	150	3.84	121	424
41	1.16	23	84	96	2.15	73	209	151	3.88	122	430
42	1.17	24	85	97	2.17	73	212	152	3.93	123	435
43	1.19	25	87	98	2.20	74	216	153	3.97	124	440
44	1.20	26	89	99	2.22	75	219	154	4.01	125	445
45	1.21	27	90	100	2.25	76	222	155	4.05	126	450
46	1.23	28	92	101	2.27	77	225	156	4.09	127	456
47	1.24	28	94	102	2.30	78	228	157	4.13	127	461
48	1.25	29	96	103	2.32	79	231	158	4.18	128	466
49	1.27	30	97	104	2.35	80	235	159	4.22	129	472
50	1.28	31	99	105	2.38	81	238	160	4.26	130	477
51	1.30	32	101	106	2.40	82	241	161	4.31	131	483
52	1.31	33	103	107	2.43	82	245	162	4.35	132	489
53	1.33	34	105	108	2.45	83	248	163	4.39	133	494
54	1.34	35	107	109	2.48	84	252	164	4.44	134	500
55	1.36	36	109	110	2.51	85	255	165	4.48	135	506











此页不做菲林 仅作为电子文档说明

双胶纸100g  
大A4规格  
印刷颜色为黑白

封面增加认证信息  
C版本升级到D版本  
更改如下：  
对应程序变更，平面件做相应整改  
D版本升级到E版本  
更改如下：  
P2页第二个警示语更改  
P12, P13内外机连接图中的C信号线改为棕/黑。

F版本  
P4增加安装环境说明

G版本  
P5/P14增加电源安装警示说明