



# MVME Series Multi-position Air handler

1.5-5 Ton

## Standard Features

- ❖ Available for cooling and heat pump applications.
- ❖ Multi-speed ECM blower motor.
- ❖ All-aluminum tubes & fins.
- ❖ Common Factory-sealed cabinet certified to achieve 2% or less leakage rate at 1.0 inch water column.
- ❖ Multi-position Installation.
- ❖ Horizontal and vertical condensate drain pans standard;
- ❖ Blower and coil easy slide out for ease of maintenance.
- ❖ Field Installed heater kits are optional: 5/7.5/10/15/20kW.
- ❖ AHRI Listed & ETL Certified.



## Midea Building Technologies Division

Add.: Midea Headquarters Building, 6 Midea Avenue, Shunde, Foshan, Guangdong, China

Postal code: 528311

[mbt.midea.com](http://mbt.midea.com) / [global.midea.com](http://global.midea.com) / [tsp.midea.com](http://tsp.midea.com)

Note: Product specifications change from time to time as product improvements and developments are released and may vary from those in this document.



*Midea-Discover Easy Comfort*



## Specifications

Model	MVME24A1MN1OC	MVME36B1MN1OC	MVME60C1MN1OC	MVME61C1MN1TC
<b>NOMINAL CAPACITY</b>				
Cooling (BTU/h)	24,000	36,000	60,000	60,000
External Static Pressure(in.w.c)	0.8	0.7	0.8	0.8
<b>ELECTRICAL DATA</b>				
Voltage / Phase (60 Hz)	208/230/1	208/230/1	208/230/1	208/230/1
Min. / Max. Voltage	187/253	187/253	187/253	187/253
Min. Circuit Amps	3.3	3.8	5.7	5.7
Max. Overcurrent Protection	15	15	15	15
<b>FAN MOTOR</b>				
Motor Type	ECM	ECM	ECM	ECM
Capacitor (uF)	/	\	\	\
Horsepower (HP)	1/3	1/2	3/4	3/4
Rated RPM	1050	1050	1050	1050
Full Load Amps (FLA)	2.6	3.0	4.5	4.5
<b>FAN BLOWER</b>				
Material	Metal	Metal	Metal	Metal
Type	Centrifugal	Centrifugal	Centrifugal	Centrifugal
Diameter(in.)	10-5/8	13	13	13
Height(in.)	8-1/8	10-5/8	10-5/8	10-5/8
<b>EVAPORATOR COIL</b>				
Type	Tube & Fin	Tube & Fin	Tube & Fin	Tube & Fin
Tube Material	Aluminum	Aluminum	Aluminum	Aluminum
Tube Size(in.)	9/32	9/32	9/32	9/32
<b>REFRIGERANT CONNECTION SIZE</b>				
Liquid Line Size (O.D.)	3/8	3/8	3/8	3/8
Suction Line Size (O.D.)	3/4	3/4	3/4	7/8

## Dimensions

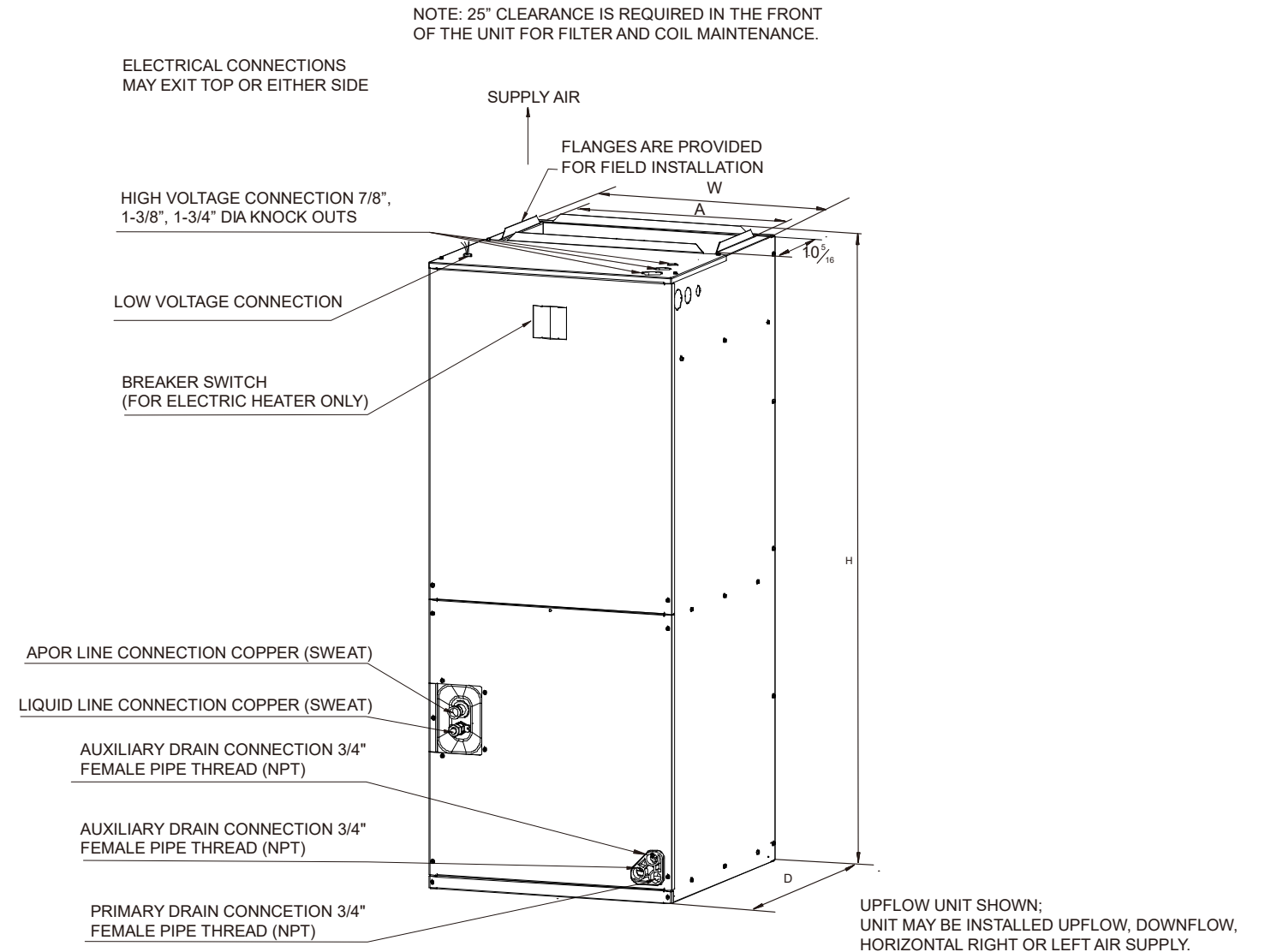

Model	MVME24A1MN1OC	MVME36B1MN1OC	MVME60C1MN1OC	MVME61C1MN1TC
<b>UNIT DIMENSION AND WEIGHTS</b>				
Height(in.)	41-3/8	46-1/2	54-1/2	54-1/2
Width(in.)	18-1/8	19-5/8	22	22
Depth(in.)	20-1/2	21-5/8	24	24
Weight(lbs.)	101	125	159	161