

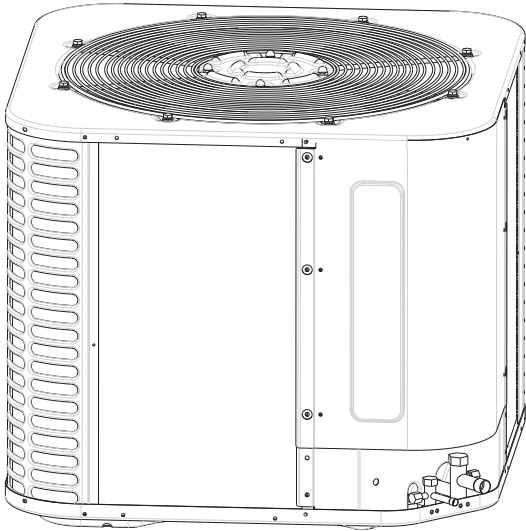

Installer's Guide

Condensing Units

**Split System Cooling Only & Heat Pump
Air Conditioner
Up to 18 SEER
2 - 5 Tons
R410A**



NOTE: Appearance of unit may vary.

ALL phases of this installation must comply with NATIONAL, STATE AND LOCAL CODES

IMPORTANT — This Document is customer property and is to remain with this unit. Please return to service information pack upon completion of work.

These instructions do not cover all variations in systems or provide for every possible contingency to be met in connection with the installation. Should further information be desired or should particular problems arise which are not covered sufficiently for the purchaser's purposes, the matter should be referred to your installing dealer or local distributor.

Note : *The manufacturer recommends installing only approved matched indoor and outdoor systems. All of the manufacturer's split systems are A.H.R.I. rated only with TXV indoor systems. Some of the benefits of installing approved matched indoor and outdoor split systems are maximum efficiency, optimum performance and the best overall system reliability.*

Table of Contents

Section 1. Safety -----	2
Section 2. Specifications -----	3
Section 3. Unit Location Considerations -----	5
Section 4. Unit Preparation -----	7
Section 5. Setting the Unit -----	7
Section 6. Refrigerant Line Considerations -----	8
Section 7. Refrigerant Line Routing -----	9
Section 8. Refrigerant Line Brazing -----	10
Section 9. Refrigerant Line Leak Check -----	12
Section 10. Evacuation -----	13
Section 11. Service Valves -----	13
Section 12. Electrical - Low Voltage -----	14
Section 13. Electrical - High Voltage -----	16
Section 14. Start Up -----	17
Section 15. System Charge djustment -----	18
Section 16. System Capacities -----	19
Section 17. Troubleshooting -----	23
Section 18. Exploded View -----	34
Section 19. Sensor Resistance -----	35

Section 1. Safety

Important - This document contains a wiring diagram and service information. This is customer property and is to remain with this unit. Please return to service information pack upon completion of work.



CAUTION

This information is intended for use by individuals possessing adequate backgrounds of electrical and mechanical experience. Any attempt to repair a central air conditioning product may result in personal injury and/or property damage. The manufacturer or seller cannot be responsible for the interpretation of this information, nor can it assume any liability in connection with its use.



WARNING

HAZARDOUS VOLTAGE!

Failure to follow this warning could result in property damage, severe personal injury, or death. Disconnect all electric power, including remote disconnects before servicing. Follow proper lockout/tagout procedures to ensure the power cannot be inadvertently energized.



WARNING

REFRIGERANT OIL!

Any attempt to repair a central air conditioning product may result in property damage, severe personal injury, or death.

These units use R-410A refrigerant which operates at 50 to 70% higher pressures than R-22. Use only R-410A approved service equipment. Refrigerant cylinders are painted a "Rose" color to indicate the type of refrigerant and may contain a "dip" tube to allow for charging of liquid refrigerant into the system. All R-410A systems with variable speed compressors use a PVE oil that readily absorbs moisture from the atmosphere. To limit this "hygroscopic" action, the system should remain sealed whenever possible. If a system has been open to the atmosphere for more than 4 hours, the compressor oil must be replaced. Never break a vacuum with air and always change the driers when opening the system for component replacement.



CAUTION

HOT SURFACE!

May cause minor to severe burning. Failure to follow this Caution could result in property damage or personal injury. Do not touch top of compressor.



CAUTION

CONTAINS REFRIGERANT!

Failure to follow proper procedures can result in personal illness or injury or severe equipment damage.

System contains oil and refrigerant under high pressure. Recover refrigerant to relieve pressure before opening system.



CAUTION

GROUNDING REQUIRED!

Failure to inspect or use proper service tools may result in equipment damage or personal injury. Reconnect all grounding devices. All parts of this product that are capable of conducting electrical current are grounded. If grounding wires, screws, straps, clips, nuts, or washers used to complete a path to ground are removed for service, they must be returned to their original position and properly fastened.



WARNING

SERVICE VALVES!

Failure to follow this warning will result in abrupt release of system charge and may result in personal injury and/or property damage. Extreme caution should be exercised when opening the Liquid Line Service valve. Turn valve stem counterclockwise only until the stem contacts the rolled edge. No torque is required.



WARNING

BRAZING REQUIRED!

Failure to inspect lines or use proper service tools may result in equipment damage or personal injury. If using existing refrigerant lines make certain that all joints are brazed, not soldered.



WARNING

HIGH LEAKAGE CURRENT!

Failure to follow this warning could result in property damage, severe personal injury, or death.

Earth connection essential before connecting electrical supply.

Section 2. Specifications Cooling Only System

Model		VEA24C2V18	VEA36C2V18	VEA48C2V18	VEA60C2V18	
Electrical Data	Cooly Capacity	Btu/H	24,000	36,000	47,000	56,000
	Voltage - Phase - Hz	V-Ph-Hz	208/230V-1Ph-60Hz			
	Minimum Circuit Ampacity	A	14.0	19.0	25.0	29.0
	Max. Overcurrent Protection	A	20	30	40	50
	Min / Max Volts	V-Ph-Hz	187/253			
Cooling	Capacity	Btu/h	24000	34500	47000	56000
	EER	Btu/h/W	11.6	11.6	11.6	10.8
	SEER	Btu/h/W	17.5	17.5	17.5	17.5
Compressor	Model		ATM240D57UFT	ATM240D57UFT	MNB42FCKMC-L	MNB42FCKMC-L
	Brand		GMCC	GMCC	MITSUBISHI	MITSUBISHI
	Type		Twin-rotary DC			
	Capacity	W/h	7130 ± 5%		13780 ± 5%	
	Input	W/h	2200 ± 5%		4040 ± 5%	
	Thermal Protector	uf	internal	internal	internal	internal
	Refrigerant oil	ml	870	870	1400	1400
	RLA	A	13.5	18.5	27.2	27.2
	LRA	A	45	45	58.1	58.1
Outdoor Motor	Model		YDK-110-8P2-AL	YDK-110-8P2-AL	WZDK200-310G	WZDK200-310G
	Brand		Chigo	Chigo	Panasonic	Panasonic
	Type		AC	AC	DC	DC
	Rated HP	W/h	1/6	1/6	1/3	1/3
	Capacitor	uF	6	6	/	/
	Speed	rpm	850	850	1050	1050
	FLA	A	1	1	1.2	1.2
Outdoor Fan	Material		Metal			
	Type		Axial flow			
	Diameter	in.	23	23	23-5/8	23-5/8
	Height	in.	4-3/8	4-3/8	4-1/2	4-1/2
	Air Flow	CFM	2950	2950	4100	4100
Outdoor Coil	Number of Row		2	2	2	2
	Tube outside dia.	mm (in.)	7 (9/32)			
Noise Level	Operation Noise Level	dB(A)	61	62	64	65
Outdoor Unit	Dimension (W x H x D)	mm	740 x 633 x 740		740 x 835 x 740	
		in.	29-1/8 x 25 x 29-1/8		29-1/8 x 32-7/8 x 29-1/8	
	Packing (W x H x D)	mm	760 x 660 x 760		760 x 875 x 760	
		in.	30 x 26 x 30		30-1/16 x 34-1/2 x 30-1/16	
	Net / Gross weight	kg	68 / 72	68 / 72	80 / 85	80 / 85
		lbs	150 / 159	150 / 159	176 / 187	176 / 187
Refrigerant System	Liquid Side / Gas Side	in.	3/8 / 3/4	3/8 / 3/4	3/8 / 7/8	3/8 / 7/8
	Factory cahрге R410A	oz	114	114	166	166
	Operating Temperatures	F	64~118	64~118	64~118	64~118

Heat Pump System

Model		VEA24H2V18	VEA36H2V18	VEA48H2V18	VEA60H2V18	
Electrical Data	Voltage - Phase - Hz	V-Ph-Hz	208/230V-1Ph-60Hz			
	Minimum Circuit Ampacity	A	14.0	19.0	25.0	29.0
	Max. Overcurrent Protection	A	20	30	40	50
	Min / Max Volts	V-Ph-Hz	187/253			
Cooling	Capacity	Btu/h	24000	34500	47000	56000
	EER	Btu/h/W	11.6	11.6	11.6	10.8
	SEER	Btu/h/W	17.5	17.5	17.5	17.5
Heating	Capacity	Btu/h	24000	34500	46500	55000
	HSPF	Btu/h/W	9.5	9.0	9.5	9.5
Compressor	Model		ATM240D57UMT	ATM240D57UMT	MNB42FCKMC-L	MNB42FCKMC-L
	Brand		GMCC	GMCC	MITSUBISHI	MITSUBISHI
	Type		Twin-rotary DC			
	Capacity	W/h	7190 ± 3%		13780 ± 5%	
	Input	W/h	1935 ± 3%		4040 ± 5%	
	Rated current (RLA)	A	8.85	8.85	11.8	11.8
	Refrigerant oil	ml	670	670	1400	1400
	Thermal Protector	uf	internal	internal	internal	internal
Outdoor Motor	LRA		45	45	58.1	58.1
	Model		YDK-110-8P2-AL	YDK-110-8P2-AL	WZDK200-310G	WZDK200-310G
	Brand		Chigo	Chigo	Panasonic	Panasonic
	Type		AC	AC	DC	DC
	Rated HP	W/h	1/6	1/6	1/3	1/3
	Capacitor	uF	6	6	/	/
	Speed	rpm	870	870	1050	1050
	FLA	A	0.8	1	2.5	2.5
Outdoor Fan	Material		Metal			
	Type		Axial flow			
	Diameter	in.	23-5/8	23-5/8	23-5/8	23-5/8
	Height	in.	2-3/4	4-1/2	4-1/2	4-1/2
	Air Flow	CFM	2400	2950	4100	4100
Outdoor Coil	Number of Row		2	2	2	2
	Tube outside dia.	mm (in.)	7 (9/32)			
Noise Level		dB(A)	61	62	64	65
Outdoor Unit	Dimension (W x H x D)	mm	740 x 633 x 740		740 x 835 x 740	
		in.	29-1/8 x 25 x 29-1/8		29-1/8 x 32-7/8 x 29-1/8	
	Packing (W x H x D)	mm	760 x 660 x 760		760 x 875 x 760	
		in.	30 x 26 x 30		30-1/16 x 34-1/2 x 30-1/16	
	Net / Gross weight	kg	64 / 68	64 / 68	80 / 85	80 / 85
		lbs	141 / 150	141 / 150	176 / 187	176 / 187
Refrigerant System	Liquid Side / Gas Side	in.	3/8 / 3/4	3/8 / 3/4	3/8 / 7/8	3/8 / 7/8
	Factory charge R410A	oz	118.16	118.16	171.08	171.08
	Metering Device		EEV	EEV	EEV	EEV

Section 3. Unit Location Considerations

3.1 Unit Dimensions

Unit Dimensions	
Models	H x W x L (Inches)
24/36	25 x 29-1/8 x 29-1/8
48/60	32-7/8 x 29-1/8 x 29-1/8

The unit's weight values is on the carton box.

When mounting the outdoor unit on a roof, be sure the roof will support the unit's weight. Properly selected isolation is recommended to prevent sound or vibration transmission to the building structure.

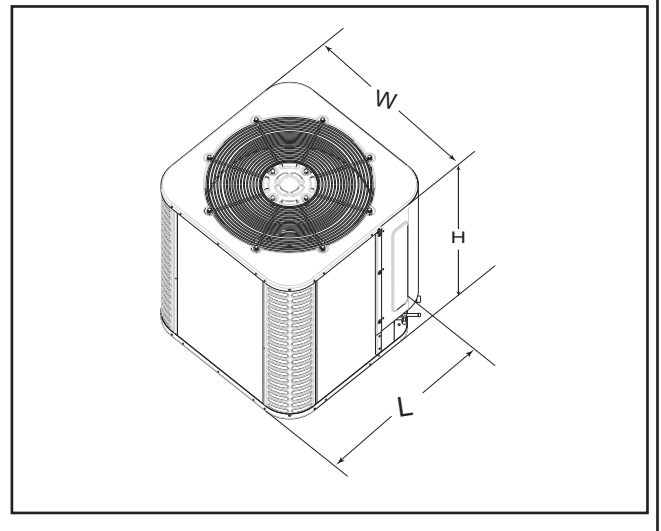

3.2 Refrigerant Piping Limits

- ☒ Maximum line length = 100 feet.
- ☒ Maximum vertical length = 50 feet.
- ☒ Compressor crankcase heat is required for line lengths over 50 feet.
- ☒ Use only the line diameters indicated in Table 5.1.
- ☒ Such as the connecting tube is more than 60 feet, does not use large Suction line than recommend.

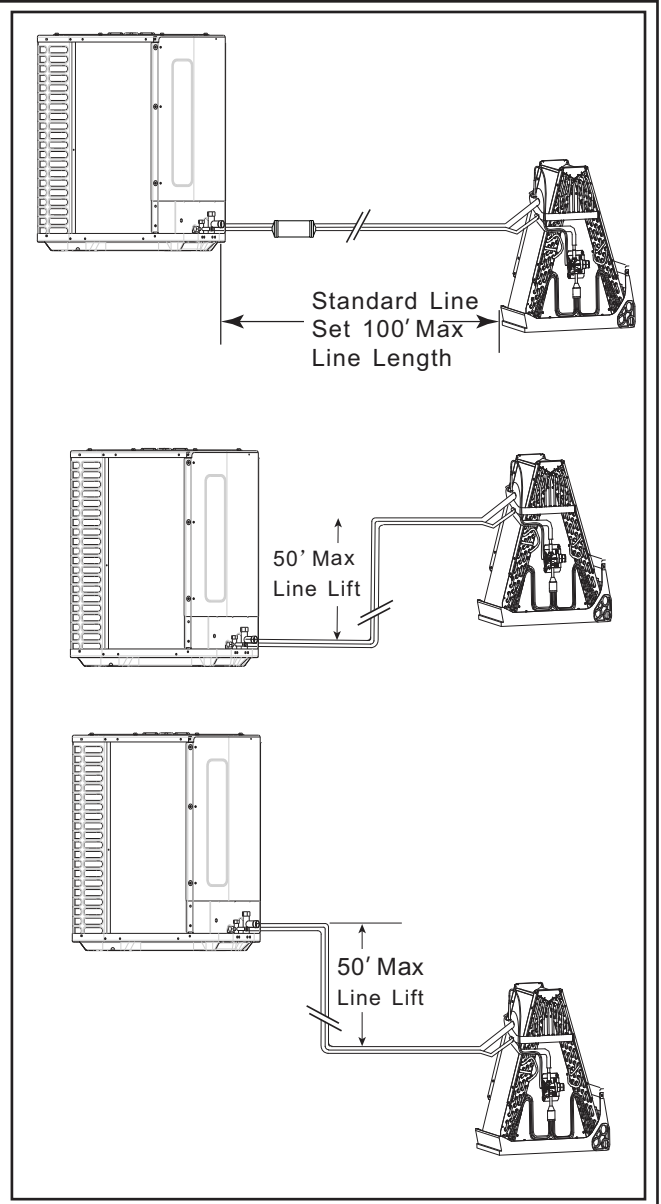

3.3 Location Restrictions

Ensure the top discharge area is unrestricted for at least 60 inches above the unit.

Clearance must be provided in front of the control box (access panels) and any other side requiring service.

Do not locate close to bedrooms, operational sounds may be objectionable.

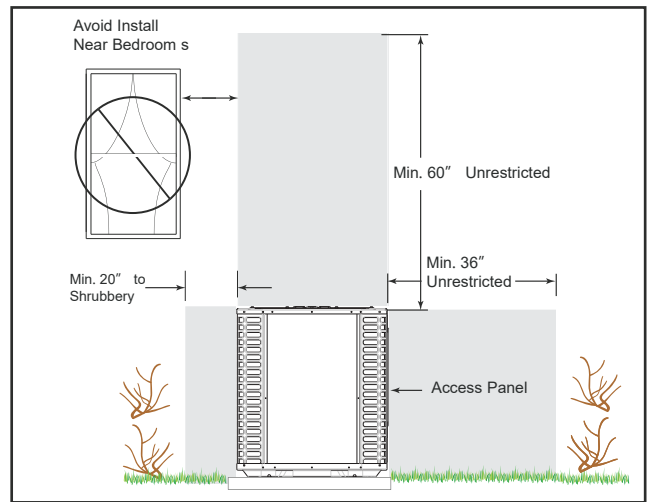

Position the outdoor unit a minimum of 20 inches from any wall or surrounding shrubbery to ensure adequate airflow.

Outdoor unit location must be far enough away from any structure to prevent excess roof runoff water from pouring directly on the unit.

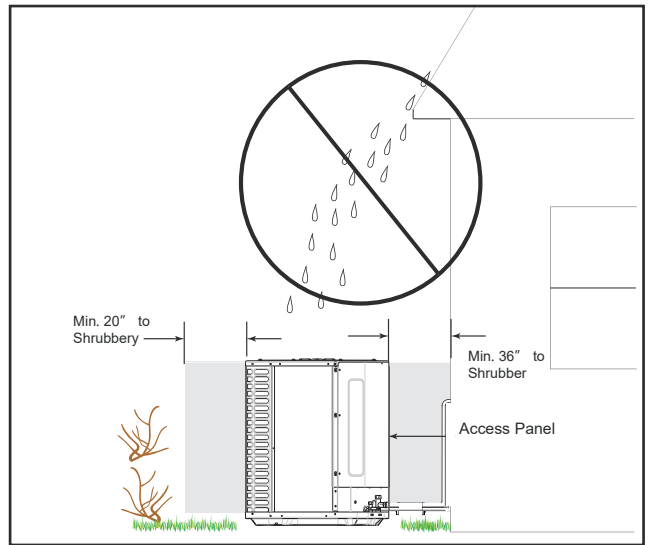

Cold Climate Considerations (Heat Pump Only)

Note: It is recommended that these precautions be taken for units being installed in areas where snow accumulation and prolonged below-freezing temperatures occur.

- Units should be elevated 3- 12 inches above the pad or rooftop, depending on local weather. This additional height will allow drainage of snow and ice melted during defrost cycle prior to its refreezing. Ensure that drain holes in unit base pan are not obstructed, preventing drainage of defrost water.
- If possible, avoid locations that are likely to accumulate snow drifts. If not possible, a snow drift barrier should be installed around the unit to prevent a build-up of snow on the sides of the unit.

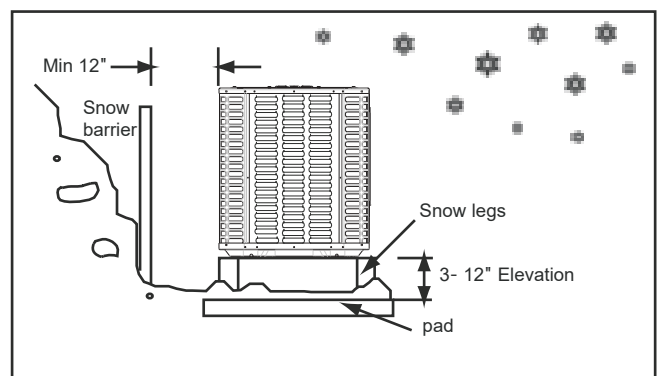

Operation Limits :

Operation mode	Outdoor temperature (°F)	Room temperature (°F)
Cooling operation	64 ~ 118	≥ 62
Heating operation	5 ~ 109	< 86

Section 4. Unit Preparation

4.1 Prepare The Unit For Installation

STEP 1 - Check for damage and report promptly to the carrier any damage found to the unit.

The charge port can be used to check to be sure the refrigerant charge has been retained during shipment.

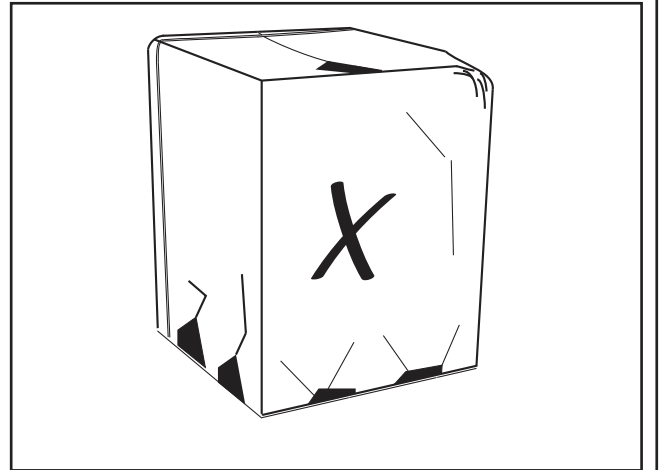

Section 5. Setting the Unit

4.2 Pad Installation

When installing the unit on a support pad, such as a concrete slab, consider the following:

- The pad should be at least 1-2" larger than the unit on all sides.
- The pad must be separate from any structure.
- The pad must be level.
- The pad should be high enough above grade to allow for drainage.
- The pad location must comply with National, State, and Local codes.

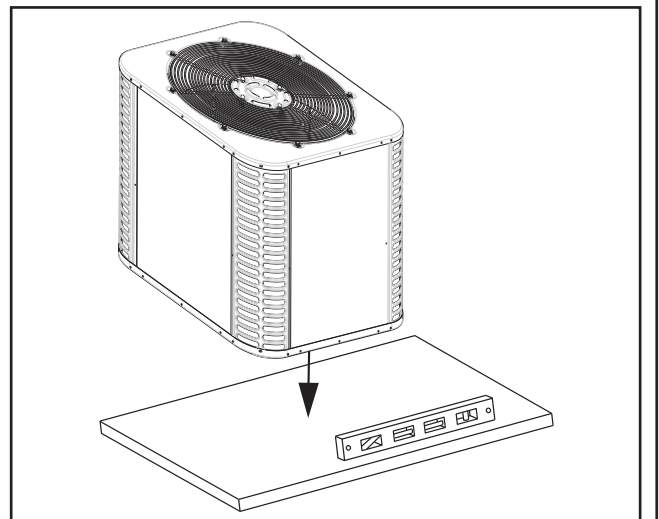

IMPORTANT NOTE:

These instructions are intended to provide a method to tie-down system to cement slab as a securing procedure for high wind areas. It is recommended to check Local Codes for tie-down methods and protocols.

#7 X 3/8" Self Tapping Screws
(Don't Exceed 3/8" long)

DETAIL A

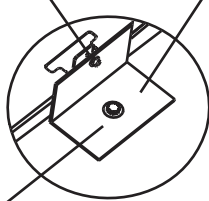

Brackets:
2" width, 1/16" thickness,
height as required.
Available from distributor
or in market place.

1/4" X 1-1/2" Hex Washer Head Concrete Screws
(3/16" Pilot Hole Needed. Pilot Hole Should Be 1/4" Deeper
Than The Fastener Embedment)

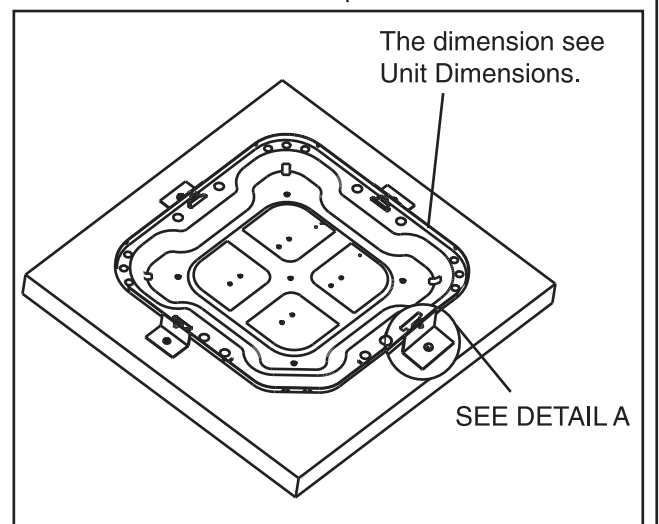

Section 6. Refrigerant Line Consideratinos

6. 1 Refrigerant Line and ServiceValve Connection Sizes

Table 5. 1

Model	Line Sizes		ServiceValve Connection Sizes	
	Suction Line	Liquid Line	Suction Line Connection	Liquid Line Connection
24/36	3/4	3/8	3/4	3/8
48/60	7/8	3/8	7/8	3/8

6. 2 Required Refrigerant Line Length

Determine required line length.

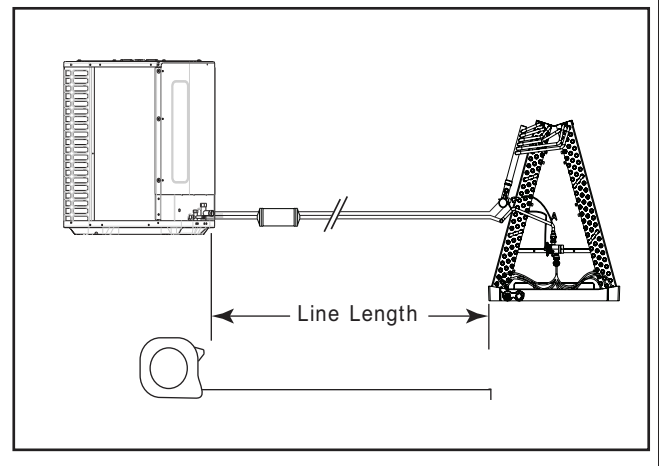

6. 3 Refrigerant Line Insulation

Important: The Suction Line must always be insulated DO NOT allow the Liquid Line and Suction Line to come in direct (metal to metal) contact.

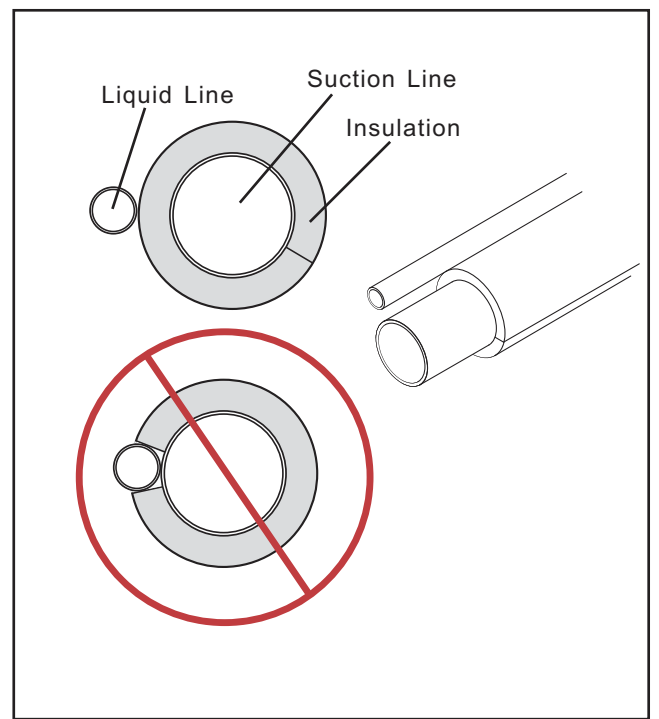

6.4 Reuse Existing Refrigerant Lines

⚠ CAUTION

If using existing refrigerant lines make certain that all joints are brazed, not soldered.

For retrofit applications, where the existing refrigerant lines will be used, the following precautions should be taken:

- ☒ Ensure that the refrigerant lines are the correct size. Refer to Section 2.2 listed and Table 5.1.
- ☒ Ensure that the refrigerant lines are free of leaks, acid, and oil.

Note: The manufacturer recommends installing only approved matched indoor and outdoor systems. All of the manufacturer's split systems are A.H.R.I. rated only with TXV indoor systems. Some of the benefits of installing approved matched indoor and outdoor split systems are maximum efficiency, optimum performance and the best overall system reliability.

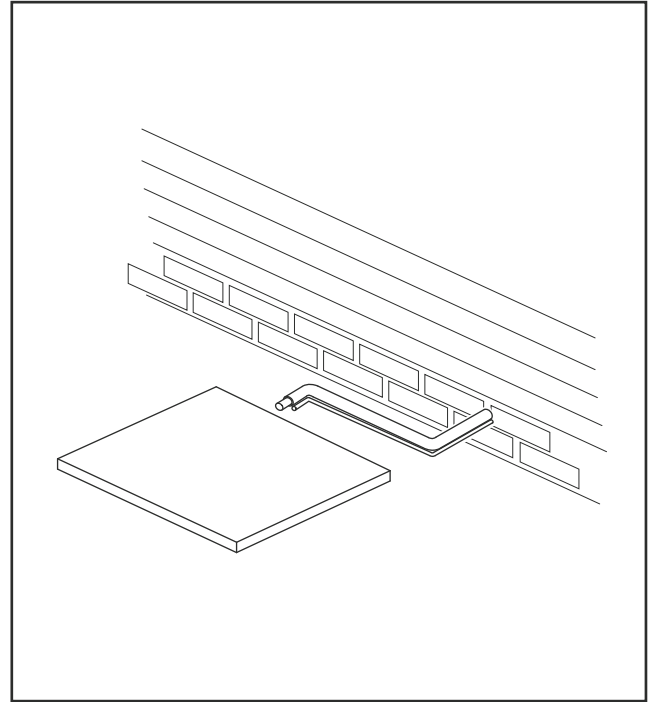

Section 7. Refrigerant Line Routing

7.1 Precautions

Important: Take precautions to prevent noise within the building structure due to vibration transmission from the refrigerant lines.

Comply with National, State, and Local Codes when isolating line sets from joists, rafters, walls, or other structural elements.

For Example:

- ☒ When the refrigerant lines have to be fastened to floor joists or other framing in a structure, use isolation type hangers.
- ☒ Isolation hangers should also be used when refrigerant lines are run in stud spaces or enclosed ceilings.
- ☒ Where the refrigerant lines run through a wall or sill, they should be insulated and isolated.
- ☒ Isolate the lines from all ductwork.
- ☒ Minimize the number of 90° turns.

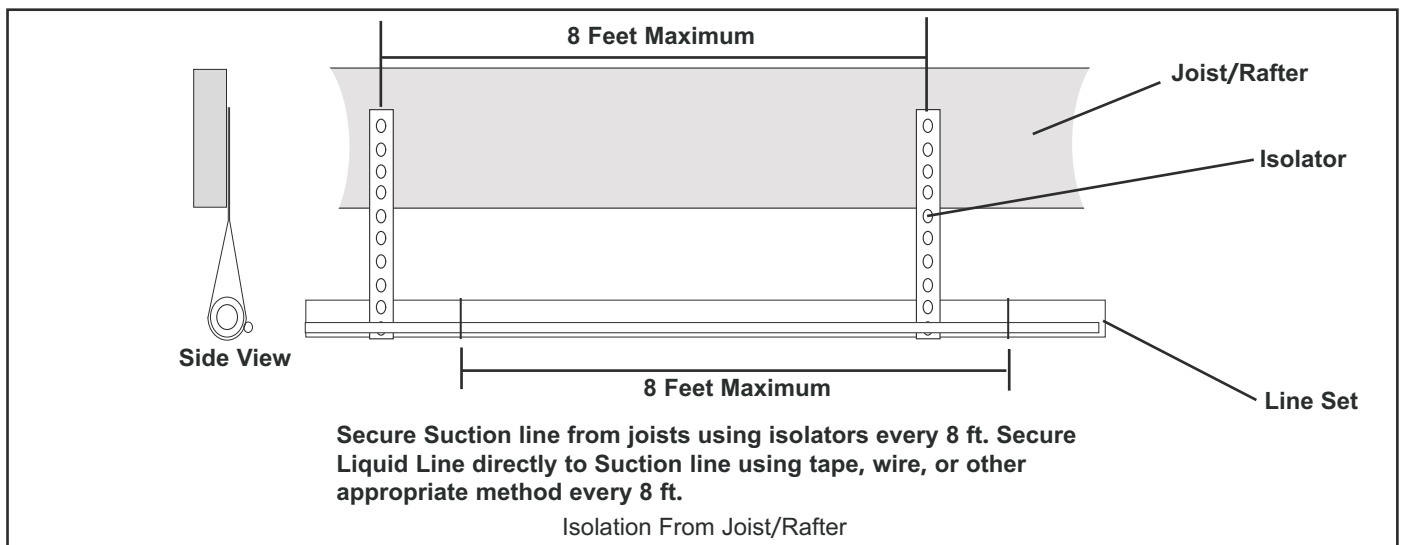

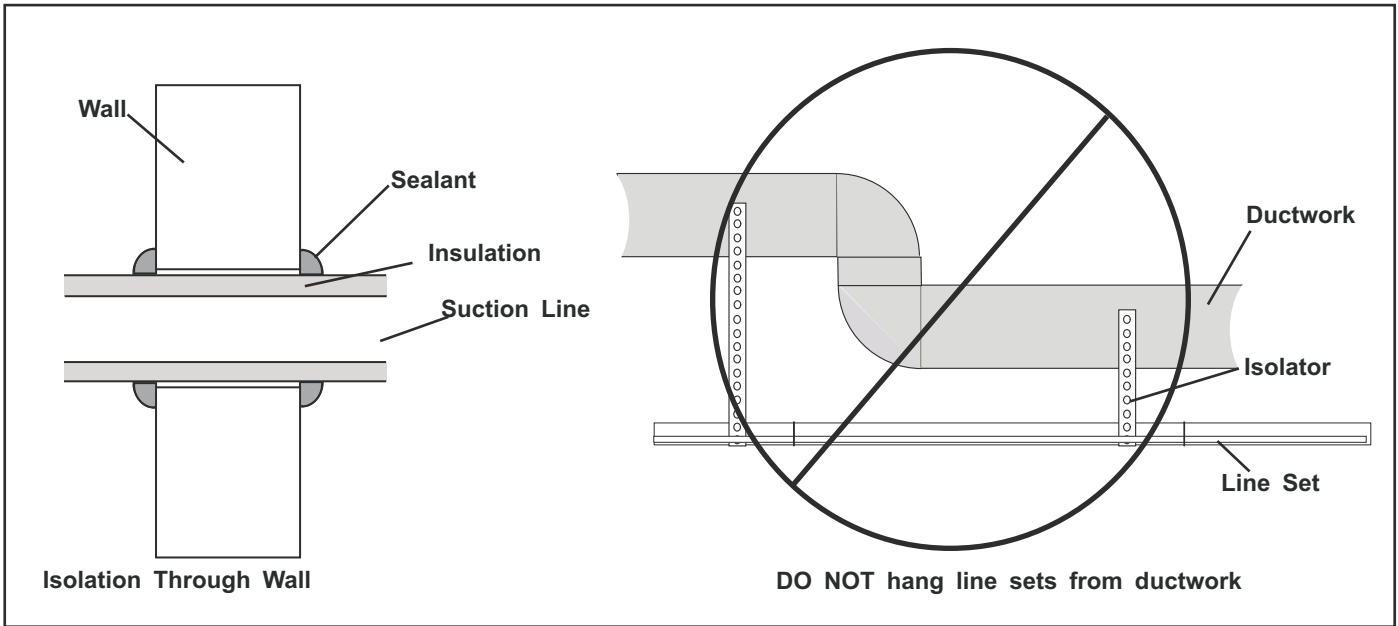
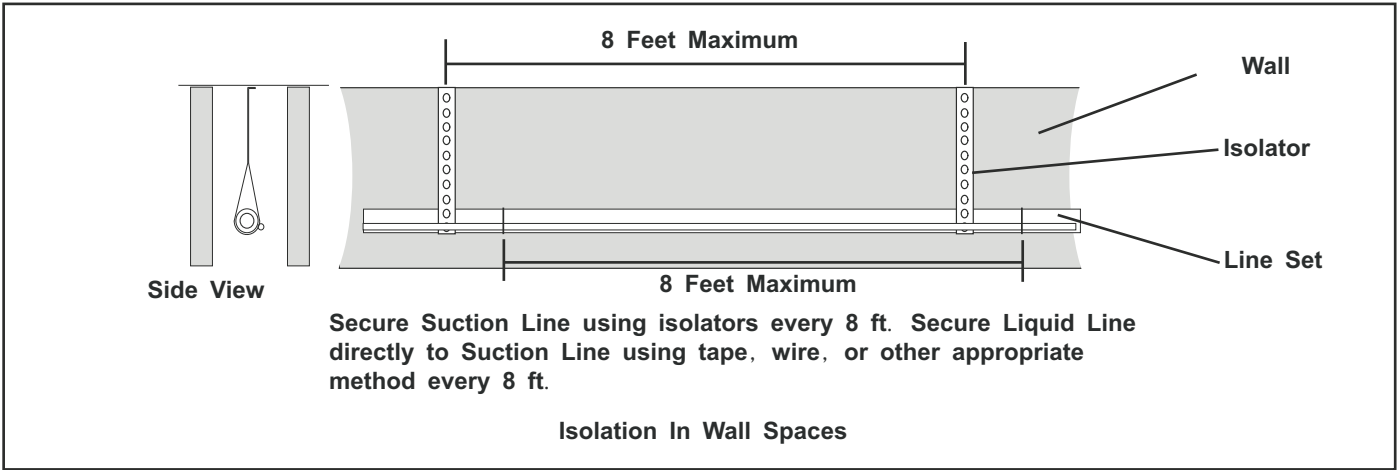

Section 8. Refrigerant Line Brazing

8.1 Braze The Refrigerant Lines

STEP 1 – Remove caps or plugs. Use a deburring tool to deburr the pipe ends. Clean both internal and external surfaces of the tubing using an emery cloth.

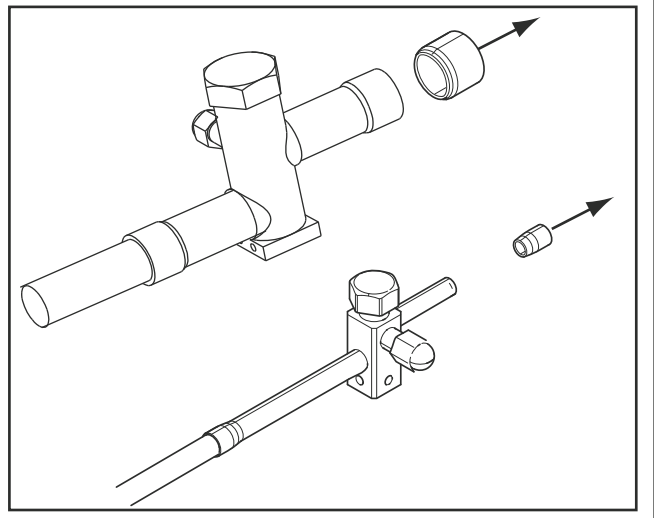

STEP 2 - Remove the pressure tap cap from both service valves.

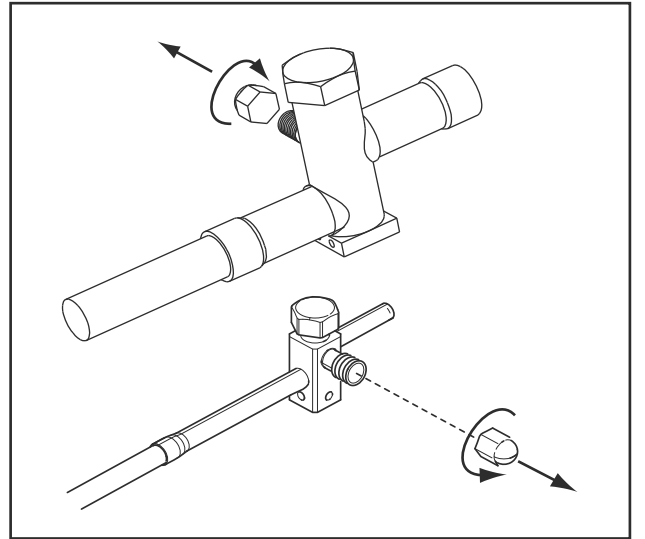

STEP 3 - Purge the refrigerant lines and indoor coil with dry nitrogen.

This pipe must have a thimble

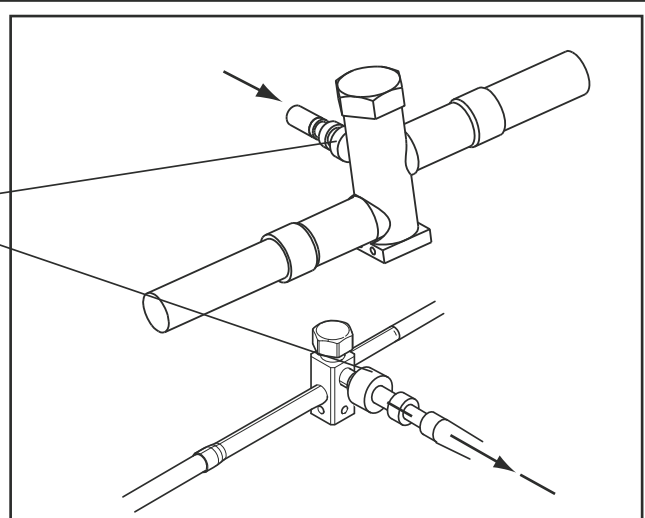

STEP 4 - Wrap a wet rag around the valve body to avoid heat damage and continue the dry nitrogen purge.

Braze the refrigerant lines to the service valves.

Check liquid line filter drier's directional flow arrow to confirm correct direction of refrigeration flow (away from outdoor unit and toward evaporator coil) as illustrated. Braze the filter drier to the Liquid Line.

Continue the dry nitrogen purge. Do not remove the wet rag until all brazing is completed.

Important: Remove the wet rag before stopping the dry nitrogen purge.

Note: Install drier in Liquid Line.

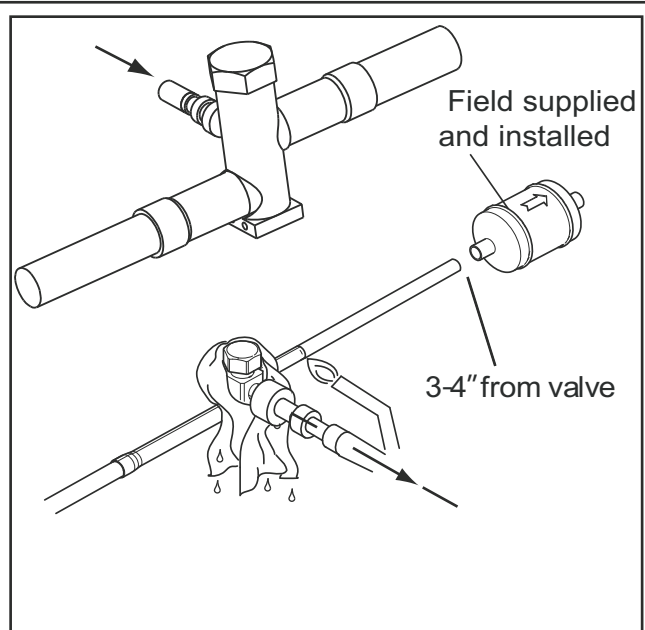

STEP 5 - Replace the pressure tap caps after the service valves have cooled.

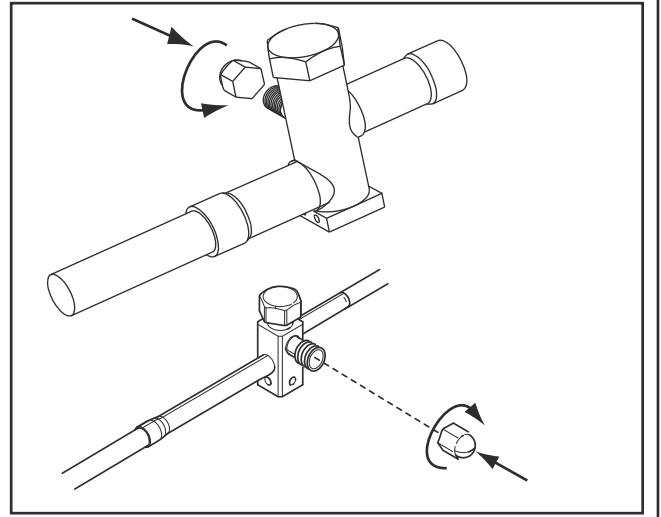

Section 9. Refrigerant Line Leak Check

9.1 Check For Leaks

STEP 1 - Pressurize the refrigerant lines and evaporator coil to 150 PSIG using dry nitrogen.

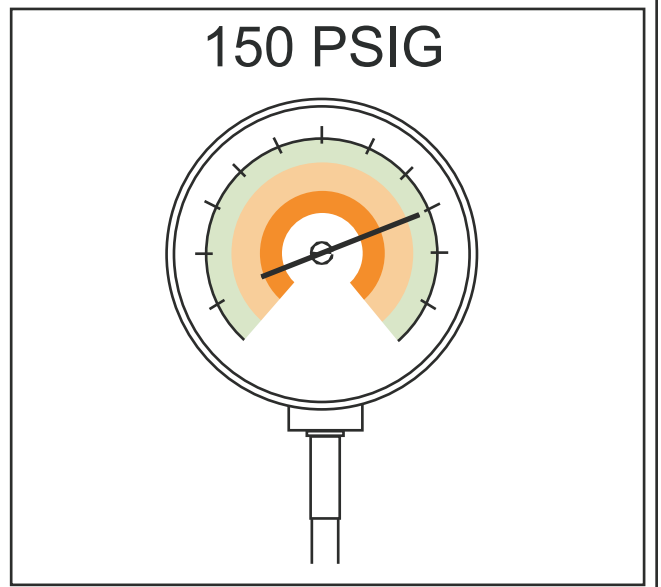

STEP 2 - Check for leaks by using a soapy solution or bubbles at each brazed location.

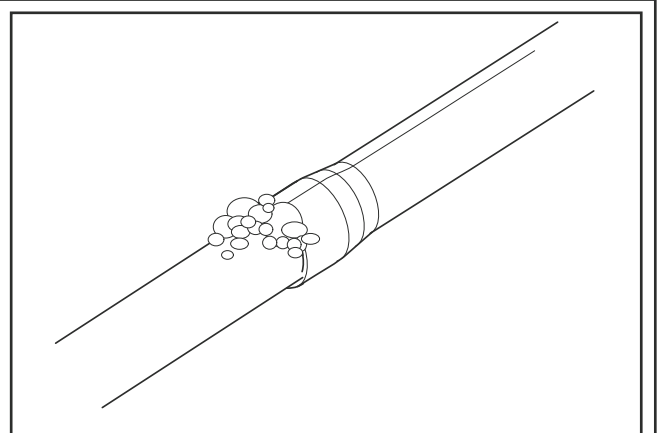

Section 10. Evacuation

10.1 Evacuate the Refrigerant Lines and Indoor Coil

Important: Do not open the service valves until the refrigerant lines and indoor coil leak check and evacuation are complete.

STEP 1- Evacuate until the micron gauge reads no higher than 350 microns, then close the valve to the vacuum pump.

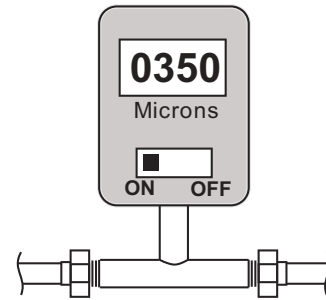

STEP 2- Observe the micron gauge. Evacuation is complete if the micron gauge does not rise above 500 microns in one (1) minute.

Once evacuation is complete blank off the vacuum pump and micron gauge, and close the valves on the manifold gauge set.



Section 11. Service Valves

11.1 Open the Service Valves

WARNING

Extreme caution should be exercised when opening the Liquid Line Service Valve. Turn counterclockwise until the valve stem just touches the rolled edge. No torque is required. Failure to follow this warning will result in abrupt release of system charge and may result in personal injury and /or property damage.

Important: Leak check and evacuation must be completed before opening the service valves.

Important: The Suction Service Valve must be opened first BEFORE opening the Liquid Service Valve!

STEP 1 - Remove service valve cap.

STEP 2 - Fully insert hex wrench into the stem and back out counterclockwise until valve stem just touches the rolled edge (approximately five (5) turns.)

STEP 3 - Replace the valve stem cap to prevent leaks. Tighten finger tight plus an additional 1/6 turn.

STEP 4 - Repeat STEPS 1 - 3 for Liquid Service Valve.

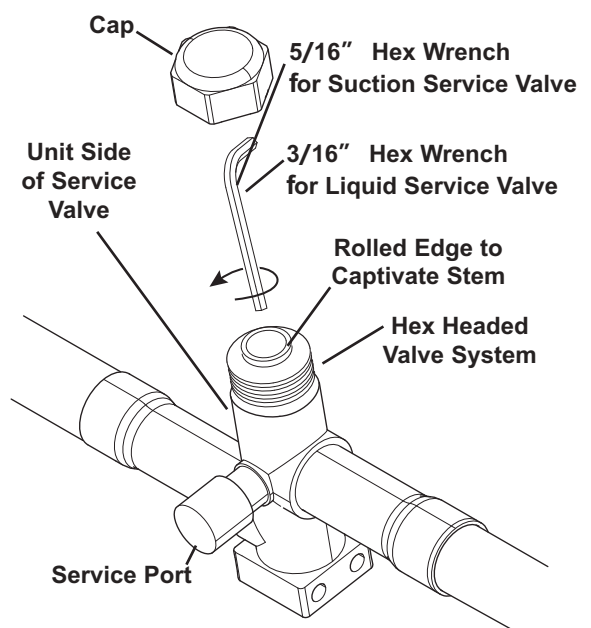

Section 12. Electrical - Low Voltage

12.1 Low Voltage Maximum Wire Length

Table 12.1 defines the maximum total length of low voltage wiring from the outdoor unit, to the indoor unit, and to the thermostat.

Field provided bushing or strain relief is required at the low voltage wire entry point.

Table 12.1

24 VOLTS	
WIRE SIZE	MAX. WIRE LENGTH
18 AWG	150 Ft.
16 AWG	225 Ft.
14 AWG	300 Ft.

12.2 Low Voltage Hook-up Diagrams

Air Handler Hook-up Diagram

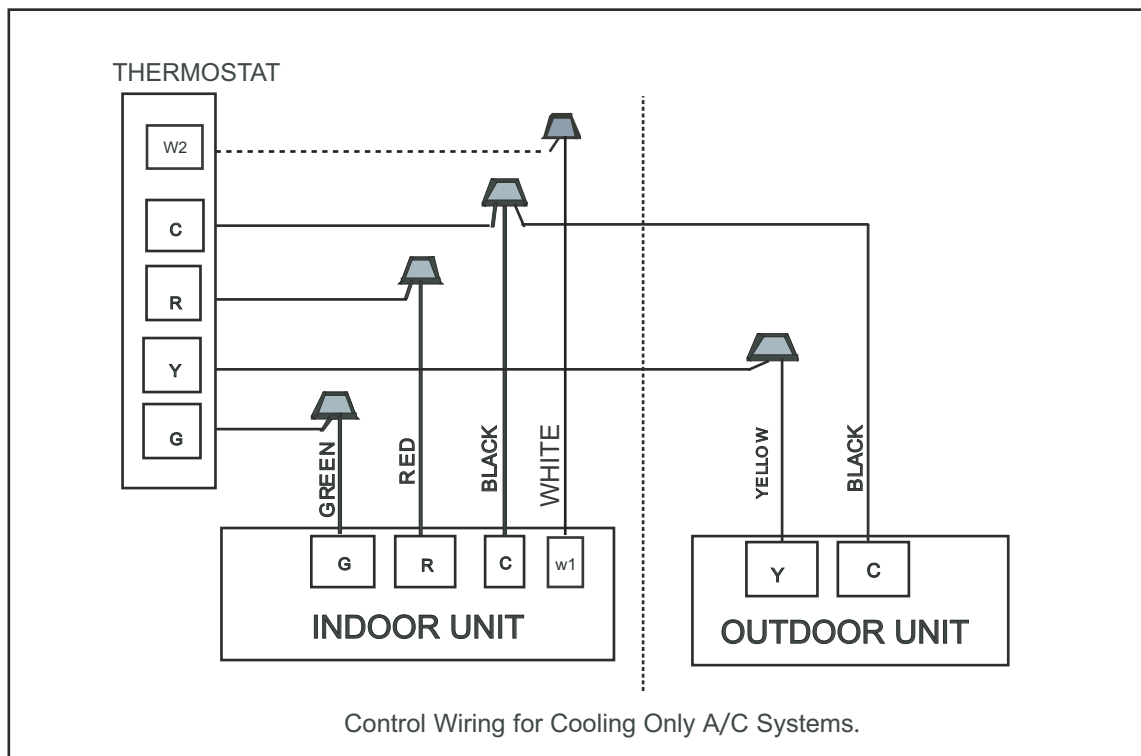
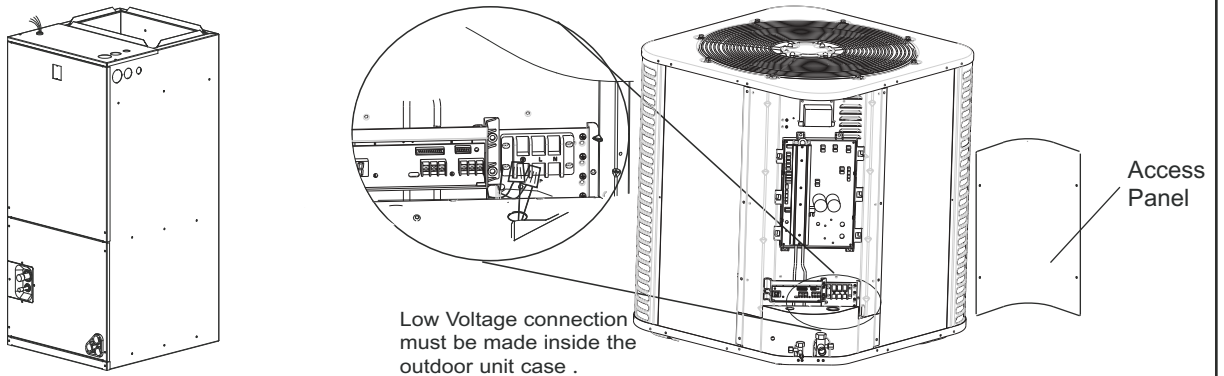

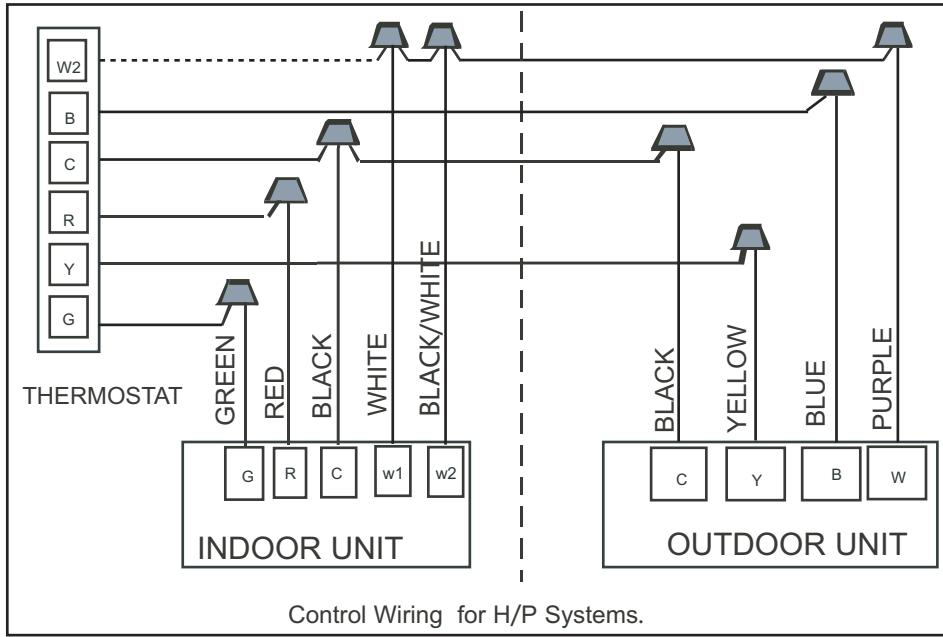

Notes:

1. Be sure power supply agrees with equipment nameplate.
2. Power wiring and grounding of equipment must comply with local codes.
3. Low voltage wiring to be No. 18 AWG minimum conductor.
4. "-----" The electric auxiliary heat connection.

Section 13. Electrical - High Voltage

13.1 High Voltage Power Supply

⚠ WARNING

LIVE ELECTRICAL COMPONENTS!

During installation, testing, servicing, and troubleshooting of this product, it may be necessary to work with live electrical components. Failure to follow all electrical safety precautions when exposed to live electrical components could result in death or serious injury.

The high voltage power supply must agree with the equipment nameplate.

Power wiring must comply with national, state, and local codes.

Follow instructions on unit wiring diagram located on the inside of the control box cover and in the Service Facts document included with the unit.

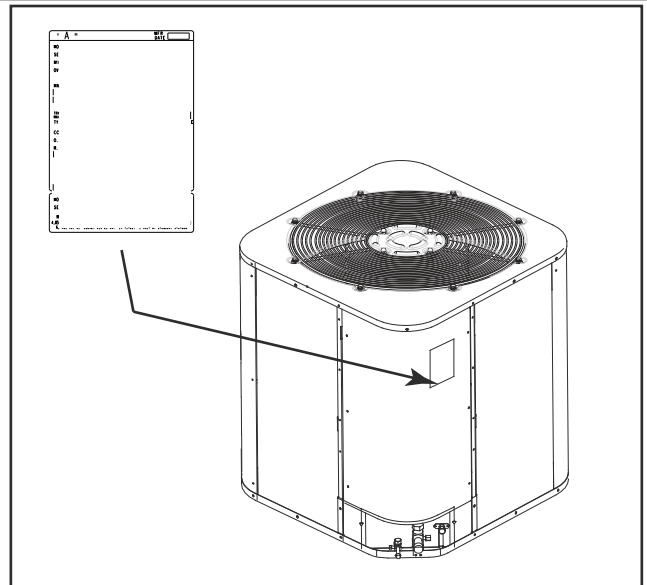

Electrical Characteristics:

Size (Btu/H)	Hz	Outdoor unit		
		Voltage	Min.	Max.
24K	60	208~230V	187V	253V
36K	60	208~230V	187V	253V
48K	60	208~230V	187V	253V
60K	60	208~230V	187V	253V

13.2 High Voltage Disconnect Switch

Install a separate disconnect switch at the outdoor unit.

Field provided flexible electrical conduit must be used for high voltage wiring.

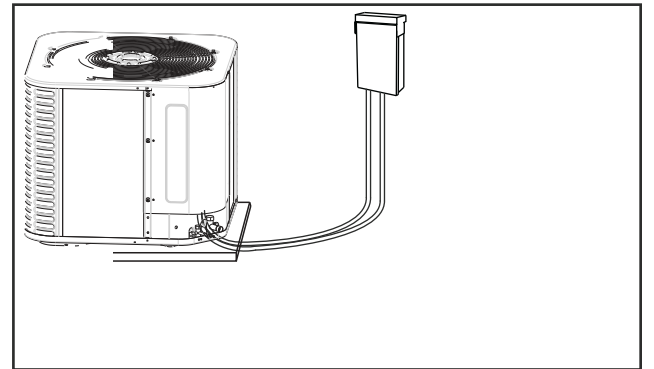

13.3 High Voltage Ground

Ground the outdoor unit per national, state, and local code requirements.

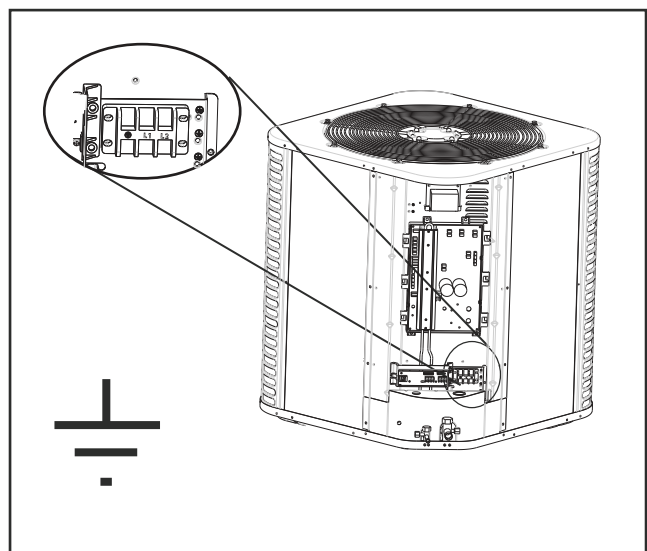

Section 14. Start Up

14.1 System Start Up

STEP 1 - Ensure Sections 6, 7, 8, 9, 10, 11, and 12 have been completed.

STEP 2 - Set System Thermostat to OFF.

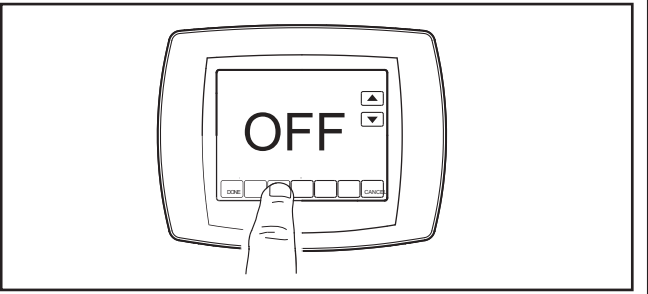

STEP 3 - Turn on disconnect to apply power to the indoor and outdoor units.

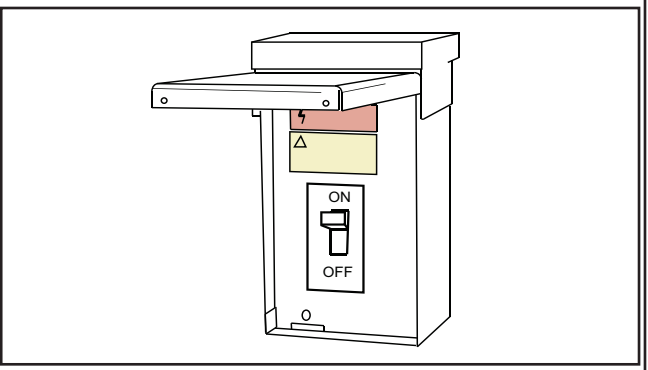

STEP 4 - Wait five (5) minutes before moving to Step 5 if no crankcase heater accessory is used,
Wait one (1) hour before starting the unit if compressor crankcase heater accessory is used and the Outdoor Ambient Temperature is below 70 °F.

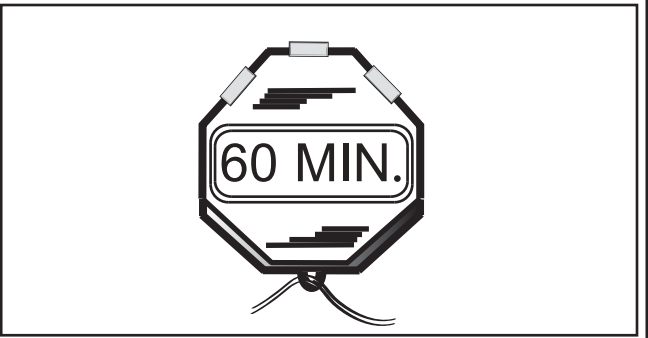

STEP 5 - Set system thermostat to ON.

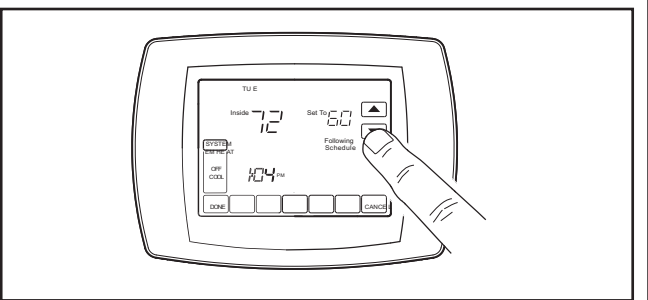

Section 15. System Charge Adjustment

15.1 charging: weigh-In Method

weigh-In Method can be used for the Initial installation, or anytime a system charge is being replaced. weigh-In Method can also be used when power is not available to the equipment site or operating conditions (indoor/Outdoor temperatures) are not In range to verify with the subcooling charging method.

A	B	C
Model	Factory Charge	charge multiplier for interconnecting refrigerant tube length
All models	(The data on nameplate)	0.6 oz/ft

Note: The factory charge in the outdoor unit is sufficient for 15 feet of standard size interconnecting liquid line.

Table 19. New Installations — calculating charge using the weigh-In method

<ol style="list-style-type: none"> 1. Measure in feet the distance between the outdoor unit and the indoor unit and record on (Line 1). Include the entire length of the line from the service valve to the IDU. 2. Enter the charge multiplier from column C. 3. Multiply the total length of refrigerant tubing (Line 1) times the value on step 2. Record the resulting value. 4. This is the amount of refrigerant to weigh-in prior to opening the service valves. 	<p>New Installation weigh-In Method worksheet</p> <ol style="list-style-type: none"> 1. Line Length (ft) _____ 2. value from Column C x _____ 3. Refrigerant((Step1-15) x Step2) = _____ <p>Note: If line length is Less than 15 feet , Refrigerant=0,don' t charge.</p>
---	--

Table 20. Sealed-System Repairs — calculating charge using the weigh-In method.

<ol style="list-style-type: none"> 1. Measure in feet the distance between the outdoor unit and the indoor unit and record on (Line 1). Include the entire length of the line from the service valve to the IDU. 2. Enter the charge multiplier from column C. 3. Multiply the total length of refrigerant tubing (Line 1) times the value on (Line 2). Record the result on (Line 3) of the worksheet. 4. Record the value in column B to Line 4 of the worksheet. 5. Add the values from step 3, step 4,and record the resulting value on Line 5. This is the amount of refrigerant to weigh-in. 	<p>New Installation weigh-In Method worksheet</p> <ol style="list-style-type: none"> 1. Line Length (ft) _____ 2. value from Column C x _____ 3. (Step1-15) x step 2 = _____ 4. Factory charge (column B) + _____ 5. Refrigerant (steps 3+4) = _____ <p>Note: If line length is Less than 15 feet , Refrigerant=factory charge</p>
---	--

Note: The only mode approved for setting validating system charge is using Charging Mode-cooling. Outdoor Temperature must be between 55°F and 120°F with Indoor Temperature kept between 70°F and 80°F.

15.2 Subcooling Charging And Refrigerant Adjustment In Cooling (Above 55°F Outdoor Temp.)

1. Check the outdoor ambient temperatures.

Subcooling (in cooling mode) is the only recommended method of charging above 55°F outdoor ambient temperatures.

For outdoor ambient temperatures below 55°F use weigh-in charge method.

Note: It is important to return in the spring or summer to accurately charge the system in the cooling mode when outdoor ambient temperature is above 55°F.

Figure 14.1

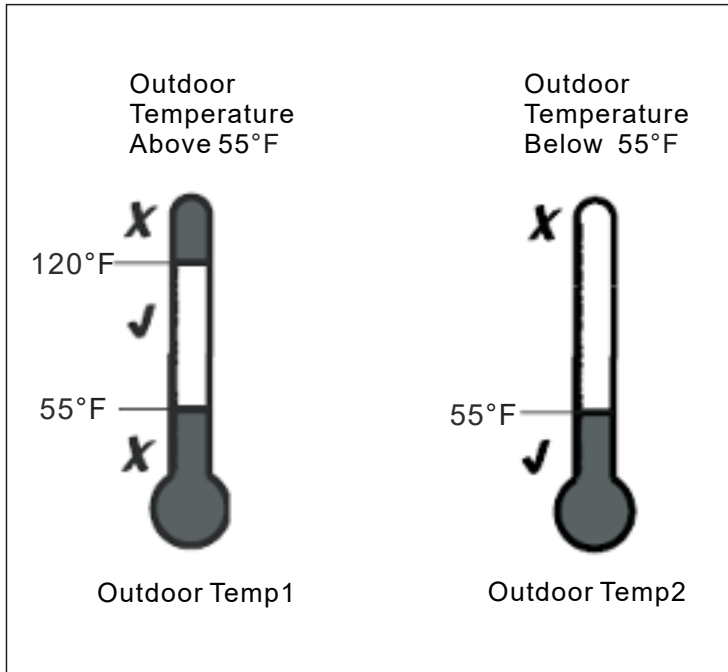

For best results, the indoor temperature should be kept between 70°F and 80°F during the install.

Figure 14.2

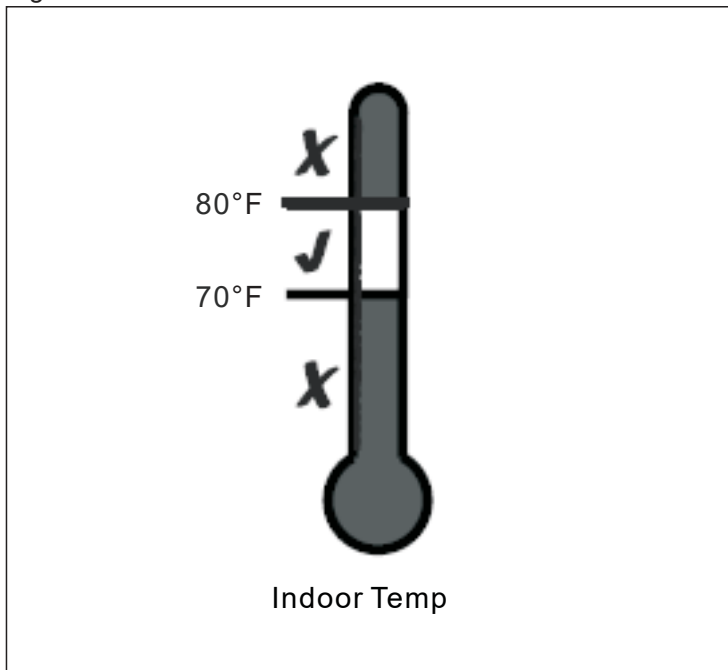

2. Ensure Sections 7,8,9,10,11,12 and 13 have been completed.

3. Stabilize the system.

After starting the system in cooling mode, short press “■” button, then “dH” and gas pipe pressure value will appear alternately. System may take 10 minutes to ramp up. Operate the system for a minimum of twenty (20) minutes.

NoteAfter a twenty (20) minute stabilization period operating at 100% capacity (i.e. once the compressor reaches the frequency shown in Table 15.1), maintain continuous operation while adjusting refrigerant charge. After adjusting, operate system for a minimum of five (5) minutes for system to stabilize, otherwise repeat step 3.

Table 15.1

Compressor Frequency in Force Mode in Cooling						
ODU Capacity	24K AC	24K HP	36K AC	36K HP	48K AC&HP	60K AC&HP
Frequency (HZ)	54	56	74	76	56	66

Figure 15.3

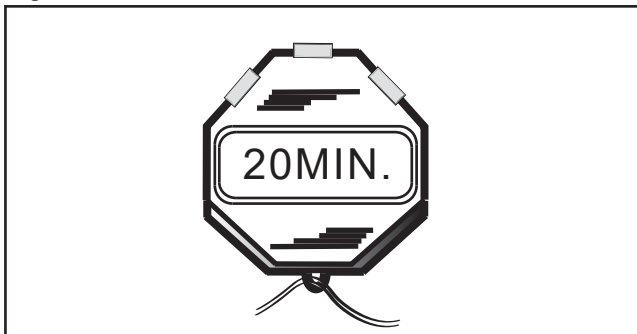

4. Calculate superheat value (According to Table 15.2)

- ▶ Measured Suction Line Temp = _____ °F
- ▶ Measured Suction Line Pressure = _____ PSIG
- ▶ Calculate superheat value = _____ °F

Note:For indoor unit with adjustable TXV, set subcooling and adjust superheat via adjustable TXV according to Table 15.4. For indoor unit with non-adjustable TXV, check the superheat and set correct subcooling according to superheat, refer to Table 15.4.

5. Calculate subcooling value (According to Table 15.3)

- ▶ Measured Liquid Line Temp. = _____ °F
- ▶ Measured Liquid Line Pressure = _____ PSIG
- ▶ Calculate subcooling value = _____ °F

Figure 14.4

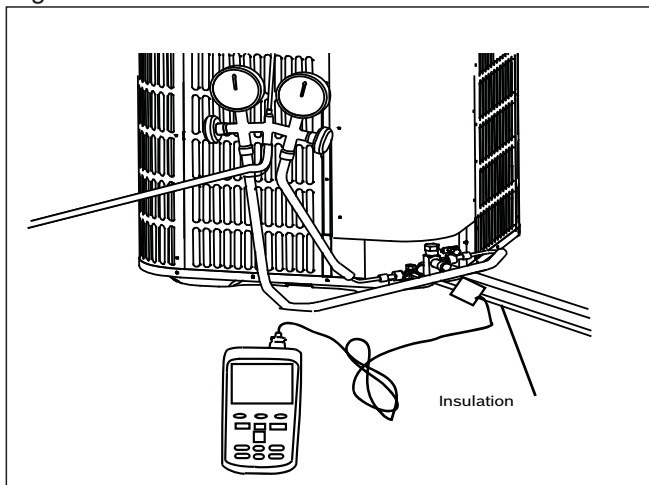

Note:If calculated subcooling value is lower than the design subcooling value (Table 15.4), please add refrigerant. Repeat steps 3 through 5.

Table 15.2 R-410A Refrigerant chart - Final Superheat

Suction Temp (°F)	Final Superheat (°F)								
	6	8	10	12	14	16	18	20	22
	Suction Gauge Pressure (PSI)								
40	105	101	97	93	89	86	82	78	75
42	109	105	101	97	93	89	86	82	78
44	114	109	105	101	97	93	89	86	82
46	118	114	109	105	101	97	93	89	86
48	123	118	114	109	105	101	97	93	98
50	128	123	118	114	109	105	101	97	93
52	133	128	123	118	114	109	105	101	97
54	138	133	128	123	118	114	109	105	101
56	143	138	133	128	123	118	114	109	105
58	148	143	138	133	128	123	118	114	109
60	153	148	143	138	133	128	123	118	114
62	159	153	148	143	138	133	128	123	118
64	164	159	153	148	143	138	133	128	123
66	150	164	159	153	148	143	138	133	128
68	176	150	164	159	153	148	143	138	133
70	182	176	150	164	159	153	148	143	138
72	188	182	176	150	164	159	153	148	143

Table 15.3 R-410A Refrigerant chart - Final Subcooling

Liquid Temp (°F)	Final Subcooling (°F)							
	6	7	8	9	10	11	12	13
	Liquid Gauge Pressure (PSI)							
55	173	176	179	182	185	188	191	195
60	188	191	195	198	201	204	208	211
65	204	208	211	215	218	221	225	229
70	221	225	229	232	236	239	243	247
75	239	243	247	251	255	259	265	266
80	259	265	266	270	275	279	283	287
85	279	283	287	291	295	300	304	309
90	300	304	309	313	318	322	327	331
95	322	327	331	336	341	346	351	355
100	346	351	355	360	365	370	376	381
105	370	376	381	386	391	397	402	407
110	397	402	407	413	418	424	430	435
115	424	430	435	441	447	453	459	465
120	453	459	465	471	477	483	489	496
125	483	489	496	502	508	515	521	528

Table 15.4

Design Subcooling / Superheat		
Model	Subcooling / °F	Superheat / °F
24K	3~5	9~11
36K	5~7	7~9
48K	10~12	7~9
60K	12~14	7~9

6. Adjust refrigerant level to attain proper gauge pressure.

Note: Add refrigerant if the subcooling reading from Table 15.3 is lower than the designed value (Table 15.4).

- ▶ Connect gauges to refrigerant bottle and unit as illustrated (Fig. 15.5). Purge
- ▶ all hoses.
- ▶ Open tank.
- ▶ Stop adding refrigerant when subcooling matches the design value (Table

Note: Recover refrigerant if the subcooling reading from Table 15.3 is higher than the design value (Table 15.4).

Figure 15.5

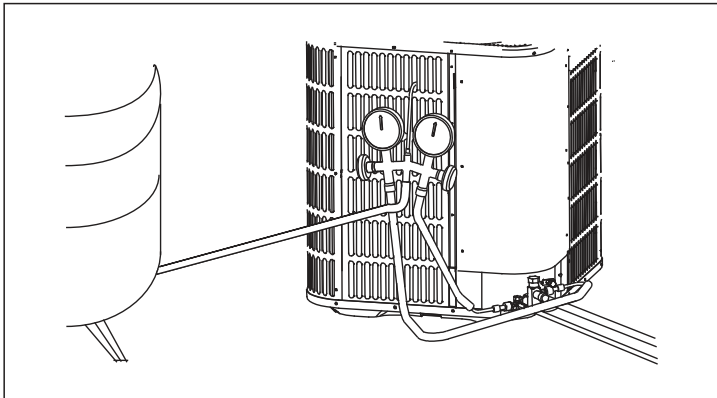

7. Stabilize the system.

- ▶ Wait 5 minutes for the system condition to stabilize between adjustments.

Note: When the subcooling matches the design value (Table 15.4), the system is properly charged.

- ▶ Remove gauges.
- ▶ Replace service port caps to prevent leaks. Tighten finger tight plus an additional 1/6 turn.

8. Record System Information for reference (Table 15.5).

Record system pressures and temperatures after charging is complete.

Table 14.5

Measured Outdoor Ambient	°F
Measured Indoor Ambient	°F
Measured Liquid Line Temp	°F
Measured Suction Line Temp	°F
Liquid Gauge Pressure	PSIG
Suction Gauge Pressure	PSIG

Section 16. System Capacities with Variable Conditions

24K Model

Cooling			ODU					
			50	77	95	109.4	114.8	118.4
IDU	68/57.2	TC	22.27	20.54	19.20	17.66	16.70	16.13
		SC	18.25	17.46	16.90	16.07	15.87	15.48
		INPUT	1.38	1.69	1.95	2.12	2.26	2.35
	71.6/60.8	TC	23.53	22.08	20.64	19.20	17.96	17.34
		SC	18.99	18.33	17.75	17.08	16.52	16.30
		INPUT	1.41	1.73	1.99	2.15	2.33	2.40
	77/64.4	TC	25.22	23.66	22.32	20.98	19.64	18.97
		SC	19.73	19.16	18.97	18.46	17.68	17.45
		INPUT	1.46	1.79	2.03	2.19	2.37	2.45
	80.6/66.2	TC	26.88	25.44	24.00	21.84	20.88	20.16
		SC	20.86	20.10	19.68	18.56	18.17	17.94
		INPUT	1.51	1.82	2.07	2.24	2.44	2.53
	84.2/68	TC	28.50	27.22	25.68	23.63	21.36	20.80
		SC	21.43	20.69	20.03	19.14	18.58	17.89
		INPUT	1.54	1.86	2.11	2.28	2.52	2.60
	89.6/73.4	TC	29.84	28.24	26.64	24.51	23.18	22.38
		SC	21.66	20.90	20.25	19.36	19.24	18.80
		INPUT	1.61	1.93	2.17	2.37	2.61	2.67

Heating			ODU					
			75.2/64.4	59/53.6	44.6/42.8	35.6/33.8	23/21.2	5/3.2
IDU	50	TC	24.77	22.91	20.64	17.54	15.69	13.62
		SC	/	/	/	/	/	/
		INPUT	1.62	1.52	1.42	1.32	1.19	1.08
	59	TC	25.89	24.78	22.32	18.97	16.96	15.18
		SC	/	/	/	/	/	/
		INPUT	1.85	1.73	1.62	1.51	1.36	1.21
	68	TC	27.84	26.64	24.00	20.40	18.24	16.56
		SC	/	/	/	/	/	/
		INPUT	2.10	1.97	1.84	1.71	1.55	1.31
	80.6	TC	30.07	28.77	25.92	22.03	19.70	17.88
		SC	/	/	/	/	/	/
		INPUT	2.24	2.11	1.97	1.83	1.65	1.44

TC: Total Capacity, SC: Sensible Capacity, INPUT: kW, Temperatures are in Farenheit, Capacities are in KBTU

36K Model

Cooling			ODU					
			10	25	35	43	46	48
IDU	68/57.2	TC	32.02	29.53	27.60	25.39	24.01	23.18
		SC	26.23	25.10	24.29	23.11	22.81	22.26
		INPUT	1.98	2.43	2.79	3.04	3.24	3.38
	71.6/60.8	TC	33.82	31.75	29.67	27.59	25.81	24.92
		SC	27.30	26.35	25.52	24.56	23.75	23.43
		INPUT	2.02	2.48	2.85	3.08	3.34	3.45
	77/64.4	TC	36.26	34.01	32.09	30.16	28.23	27.27
		SC	28.36	27.55	27.27	26.54	25.41	25.09
		INPUT	2.10	2.56	2.91	3.14	3.41	3.52
	80.6/66.2	TC	38.64	36.57	34.50	31.40	30.02	28.98
		SC	29.99	28.89	28.29	26.69	26.11	25.79
		INPUT	2.17	2.61	2.97	3.21	3.50	3.62
	84.2/68	TC	40.98	39.13	36.92	33.96	30.71	29.90
		SC	30.81	29.74	28.79	27.51	26.71	25.71
		INPUT	2.21	2.67	3.03	3.27	3.61	3.73
	89.6/73.4	TC	42.89	40.59	38.30	35.23	33.32	32.17
		SC	31.14	30.04	29.10	27.83	27.65	27.02
		INPUT	2.31	2.78	3.12	3.40	3.74	3.84

Heating		ODU						
		75.2/64.4	59/53.6	44.6/42.8	35.6/33.8	23/21.2	5/3.2	
IDU	10	TC	35.60	32.93	29.67	25.22	22.55	19.58
		SC	/	/	/	/	/	/
		INPUT	2.33	2.18	2.04	1.90	1.71	1.55
	15	TC	37.22	35.61	32.09	27.27	24.38	21.82
		SC	/	/	/	/	/	/
		INPUT	2.66	2.50	2.33	2.17	1.96	1.75
	20	TC	40.02	38.30	34.50	29.33	26.22	23.81
		SC	/	/	/	/	/	/
		INPUT	3.02	2.84	2.65	2.46	2.23	1.88
	27	TC	43.22	41.36	37.26	31.67	28.32	25.71
		SC	/	/	/	/	/	/
		INPUT	3.23	3.03	2.84	2.64	2.38	2.07

TC: Total Capacity, SC: Sensible Capacity, INPUT: kW, Temperatures are in Farenheit, Capacities are in KBTU

48K Model

Cooling			ODU					
			10	25	35	43	46	48
IDU	68/57.2	TC	43.62	40.23	37.60	34.59	32.71	31.58
		SC	35.74	34.20	33.09	31.48	31.08	30.32
		INPUT	2.70	3.31	3.81	4.15	4.42	4.61
	71.6/60.8	TC	46.08	43.25	40.42	37.59	35.17	33.95
		SC	37.19	35.90	34.76	33.46	32.35	31.92
		INPUT	2.76	3.38	3.89	4.20	4.55	4.70
	77/64.4	TC	49.39	46.33	43.71	41.09	38.46	37.15
		SC	38.64	37.53	37.15	36.16	34.62	34.18
		INPUT	2.86	3.49	3.97	4.29	4.64	4.80
	80.6/66.2	TC	52.64	49.82	47.00	42.77	40.89	39.48
		SC	40.85	39.36	38.54	36.35	35.57	35.14
		INPUT	2.96	3.56	4.05	4.37	4.78	4.94
	84.2/68	TC	55.82	53.31	50.29	46.27	41.83	40.73
		SC	41.97	40.51	39.23	37.48	36.39	35.03
		INPUT	3.02	3.64	4.13	4.46	4.93	5.08
	89.6/73.4	TC	58.43	55.30	52.17	48.00	45.39	43.82
		SC	42.42	40.92	39.65	37.92	37.67	36.81
		INPUT	3.15	3.78	4.25	4.64	5.10	5.23

Heating			ODU					
			75.2/64.4	59/53.6	44.6/42.8	35.6/33.8	23/21.2	5/3.2
IDU	10	TC	47.99	44.39	39.99	33.99	30.39	26.39
		SC	/	/	/	/	/	/
		INPUT	3.13	2.94	2.75	2.56	2.31	2.09
	15	TC	50.16	48.00	43.25	36.76	32.87	29.41
		SC	/	/	/	/	/	/
		INPUT	3.58	3.36	3.14	2.92	2.64	2.36
	20	TC	53.94	51.62	46.50	39.53	35.34	32.09
		SC	/	/	/	/	/	/
		INPUT	4.07	3.82	3.57	3.32	3.00	2.53
	27	TC	58.26	55.74	50.22	42.69	38.17	34.65
		SC	/	/	/	/	/	/
		INPUT	4.35	4.09	3.82	3.55	3.21	2.79

TC: Total Capacity, SC: Sensible Capacity, INPUT: kW, Temperatures are in Farenheit, Capacities are in KBTU

60K Model

Cooling			ODU					
			10	25	35	43	46	48
IDU	68/57.2	TC	51.97	47.94	44.80	41.22	38.98	37.63
		SC	42.58	40.75	39.42	37.51	37.03	36.13
		INPUT	2.70	3.31	3.81	4.15	4.42	4.61
	71.6/60.8	TC	54.90	51.53	48.16	44.79	41.90	40.45
		SC	44.32	42.77	41.42	39.86	38.55	38.03
		INPUT	2.76	3.38	3.89	4.20	4.55	4.70
	77/64.4	TC	58.85	55.20	52.08	48.96	45.83	44.27
		SC	46.04	44.72	44.27	43.08	41.25	40.73
		INPUT	2.86	3.49	3.97	4.29	4.64	4.80
	80.6/66.2	TC	62.72	59.36	56.00	50.96	48.72	47.04
		SC	48.68	46.89	45.92	43.32	42.39	41.87
		INPUT	2.96	3.56	4.05	4.37	4.78	4.94
	84.2/68	TC	66.51	63.52	59.92	55.13	49.84	48.54
		SC	50.01	48.27	46.74	44.65	43.36	41.74
		INPUT	3.02	3.64	4.13	4.46	4.93	5.08
	89.6/73.4	TC	69.62	65.89	62.16	57.19	54.08	52.21
		SC	50.55	48.76	47.24	45.18	44.89	43.86
		INPUT	3.15	3.78	4.25	4.64	5.10	5.23

Heating			ODU					
			75.2/64.4	59/53.6	44.6/42.8	35.6/33.8	23/21.2	5/3.2
IDU	10	TC	56.76	52.50	47.30	40.21	35.95	31.22
		SC	/	/	/	/	/	/
		INPUT	3.27	3.07	2.87	2.67	2.41	2.18
	15	TC	59.33	56.78	51.15	43.48	38.87	34.78
		SC	/	/	/	/	/	/
		INPUT	3.74	3.51	3.28	3.05	2.76	2.46
	20	TC	63.80	61.05	55.00	46.75	41.80	37.95
		SC	/	/	/	/	/	/
		INPUT	4.25	3.99	3.73	3.47	3.13	2.65
	27	TC	68.90	65.93	59.40	50.49	45.14	40.99
		SC	/	/	/	/	/	/
		INPUT	4.55	4.27	3.99	3.71	3.35	2.91

TC: Total Capacity, SC: Sensible Capacity, INPUT: kW, Temperatures are in Farenheit, Capacities are in KBTU

Section 17. Troubleshooting

17.1 Compressor Driver Chip

The compressor driver chip controls 2 LED lights, namely red light and green light, and the meaning of the fault light display is as follows:

Failure	Green light	Red light
<i>DC bus voltage over/low protection (MCE failure)</i>	ON	ON
<i>Normal standby</i>	ON	OFF
<i>EEPROM fault</i>	ON	FLASH
<i>Normal operation</i>	OFF	ON
<i>Compressor stall protection</i>	OFF	FLASH
<i>Phase protection, zero speed protection, synchronous fault</i>	FLASH	ON
<i>IGBT overcurrent or module protection</i>	FLASH	OFF
<i>Communication failure (host data can not be received for 1min)</i>	FLASH	FLASH

* The flashing frequency is 2.5Hz, and display of fault code is based on the actual protection time.

17.2 Troubleshooting of Sensor

Cooling Mode

Sensor	Operation mode in case of failure
T3	<i>The maximum operating temperature shall not exceed 140 °F</i>
T4	<i>Operate at T4 = 50 ° C</i>
TP	<i>Operate at T4 = 50 ° C for T4 temperature frequency limiting and current frequency limiting</i>

Heating Mode

Sensor	Operation mode in case of failure
T3	<i>T4 <7° C: After 40 minutes of continuous operation, the compressor is forced to defrost once, and the defrosting time is 3 minutes. T4 >=7° C: After 90 minutes of continuous operation, the compressor is forced to defrost once, and the defrosting time is 2 minutes.</i>
T4	<i>Operate at T4 = 15 ° C</i>
TP	<i>Operate at T4 = 15 ° C for T4 temperature frequency limiting and current frequency limiting Expansion valve operates at Tp = 130 ° C</i>

17.3 Error Code

The fault codes for outdoor unit as follows:

NO	Error Code	Status description
1	E4	T4 outdoor ambient temperature sensor fault
2	E5	T5 Discharge temperature sensor fault
3	E6	T3 Outdoor heat exchanger temperature sensor fault
4	E9	AC voltage overvoltage / undervoltage protection
5	E10	EEPROM fault
6	H0	Communication fault of master board and driver chip
7	H4	IPM Module high temperature abnormal protection
8	H5	Refrigerant low pressure abnormal protection
9	H6	Exhaust high temperature abnormal protection
10	P1	High pressure protection
11	P2	Low pressure protection
12	P3	Inverter overcurrent protection
13	P4	Exhaust overheating protection
14	P5	T3 or T3B condenser pipe overheating protection
15	P6	IPM module protection
16	P9	DC fan motor fault
17	P11	T2 high temperature protection (Heating mode)

1. Error code: E4: T4 outdoor ambient temperature sensor fault

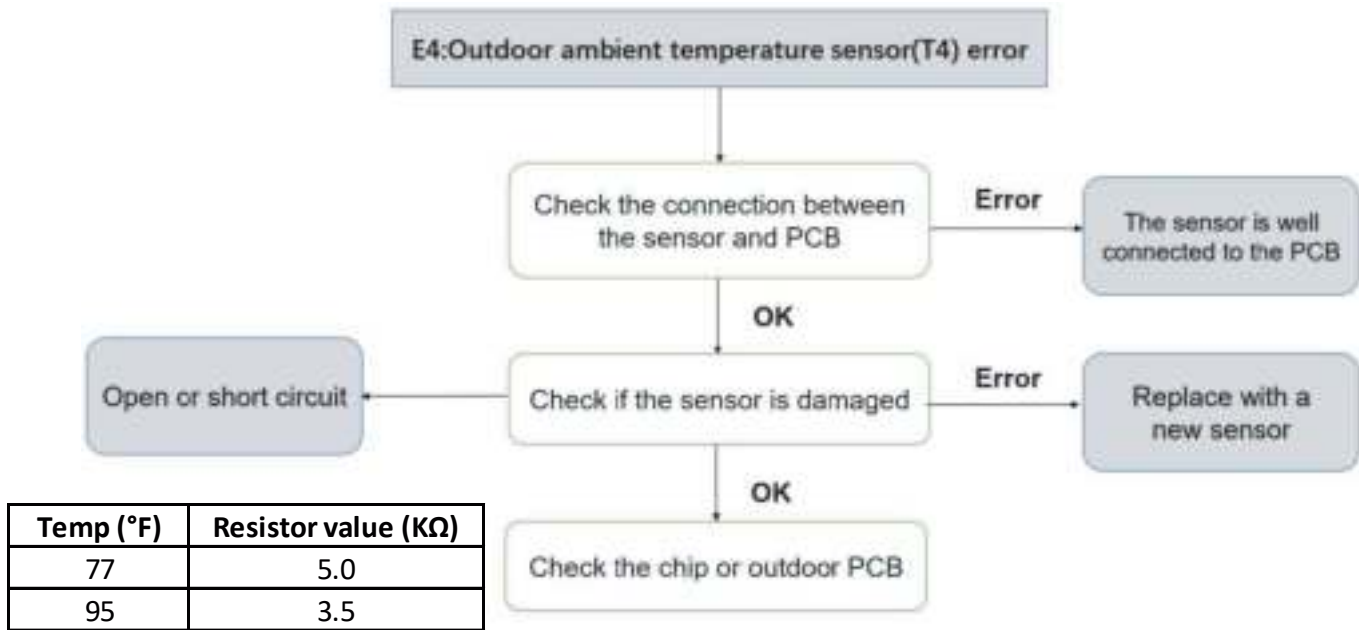

2. Error code: E5 : T5 Discharge temperature sensor fault

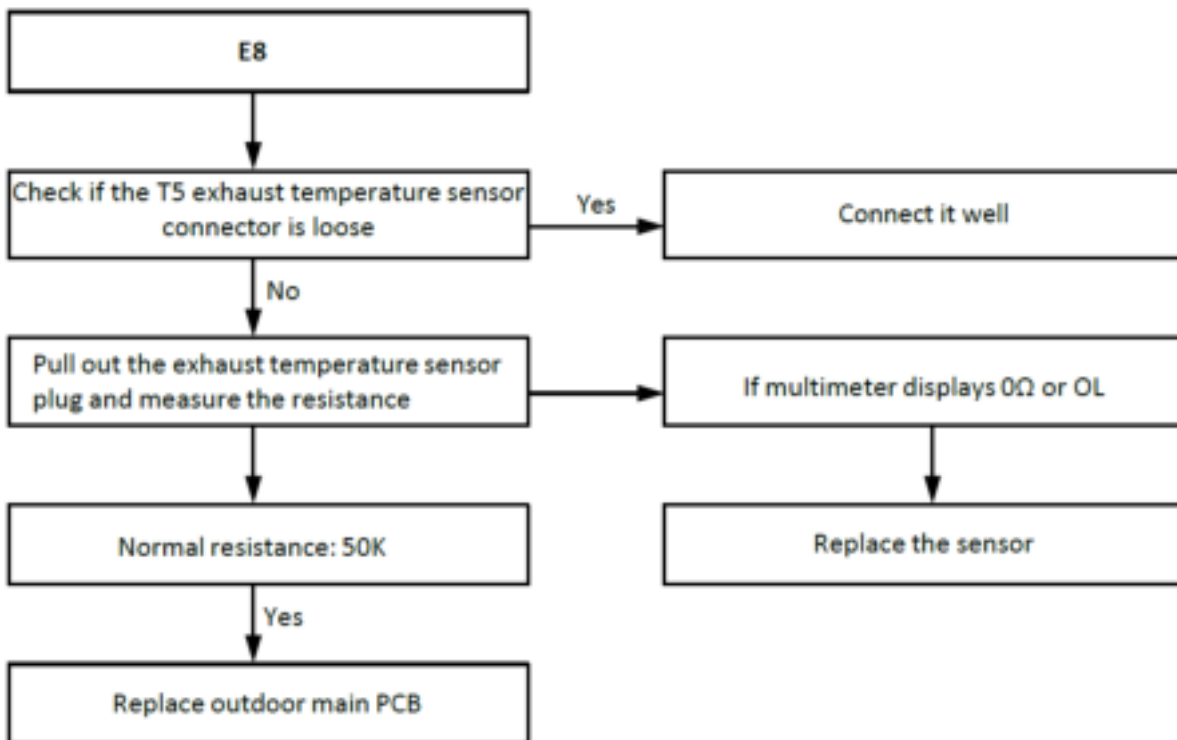

3. Error code: E6: T3 Condenser pipe temperature sensor fault (Outlet)

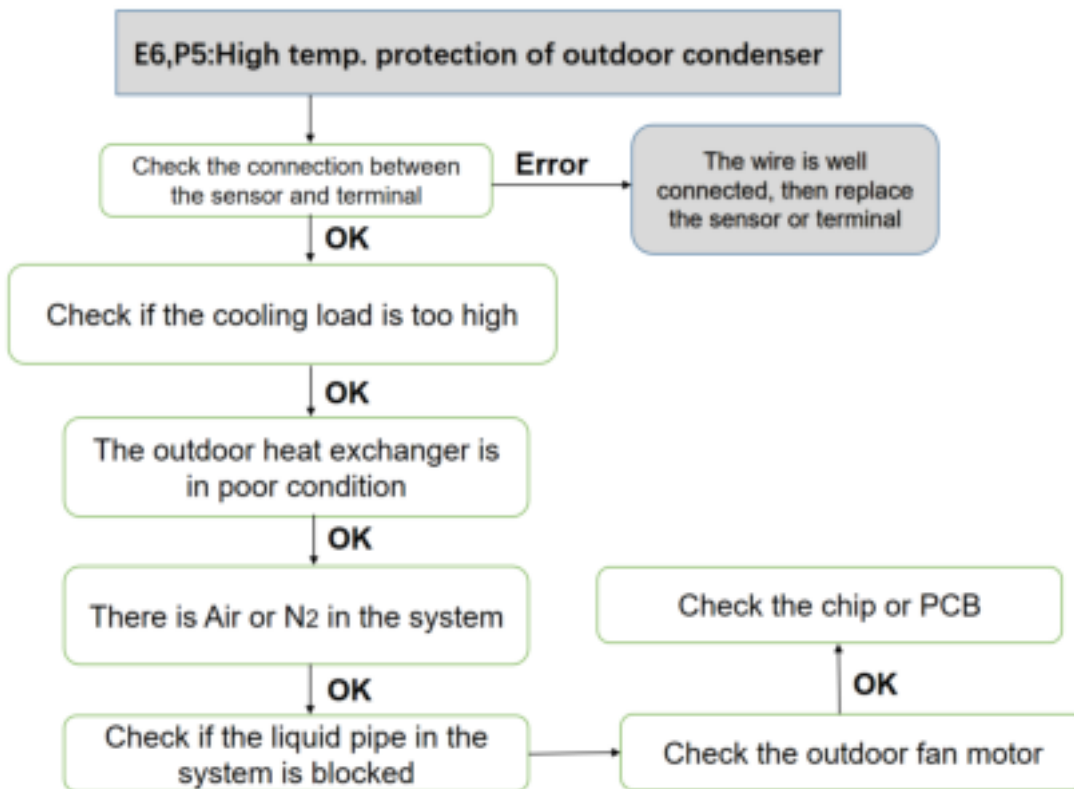

4. Error code: E9: AC voltage overvoltage / undervoltage protection

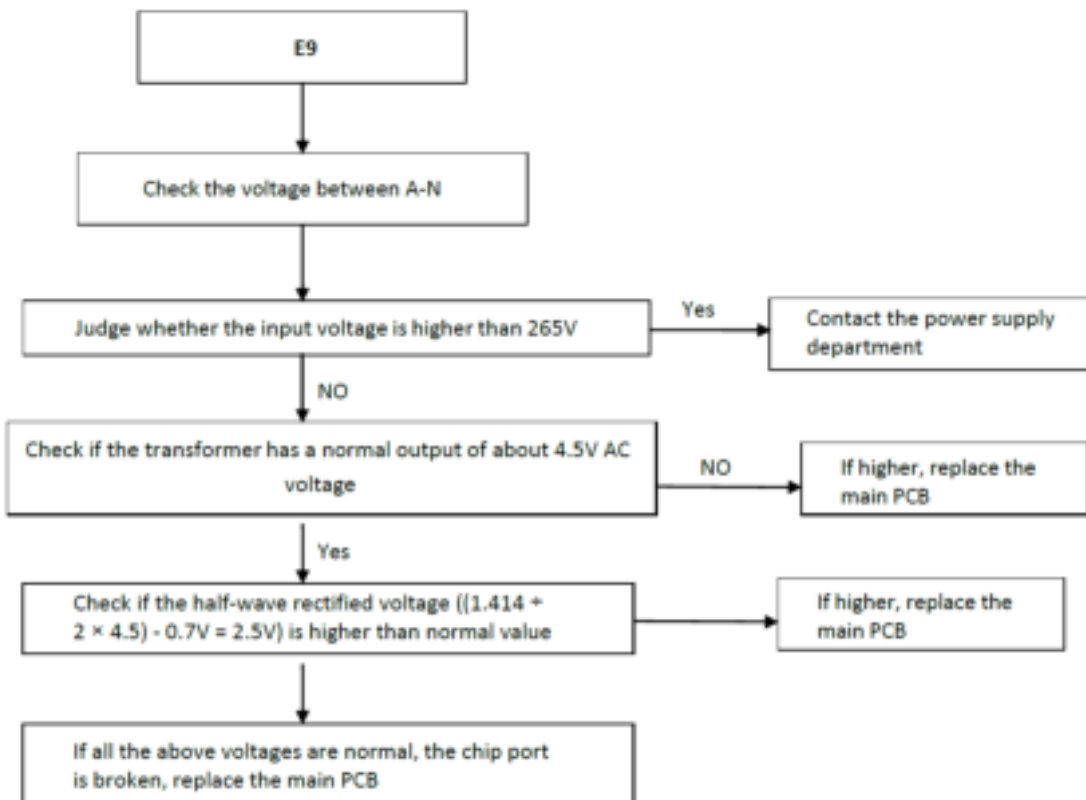

5. Error code: E10: EEPROM error

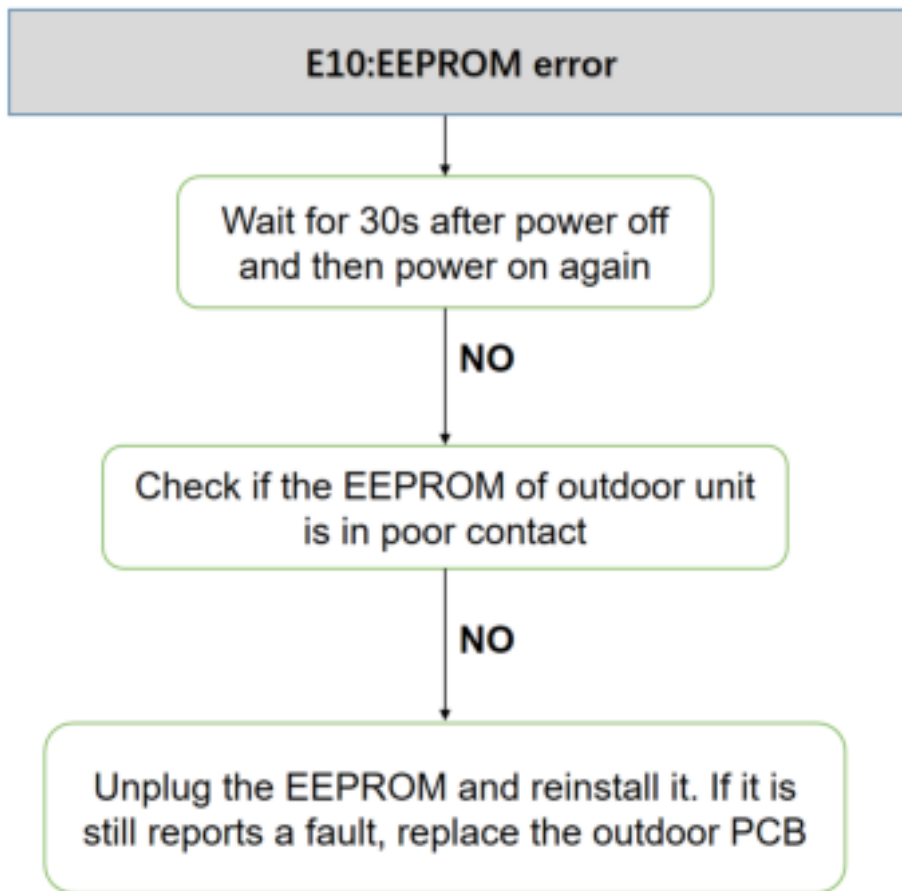

6. Error code: H0: Communication fault of master board and drive board

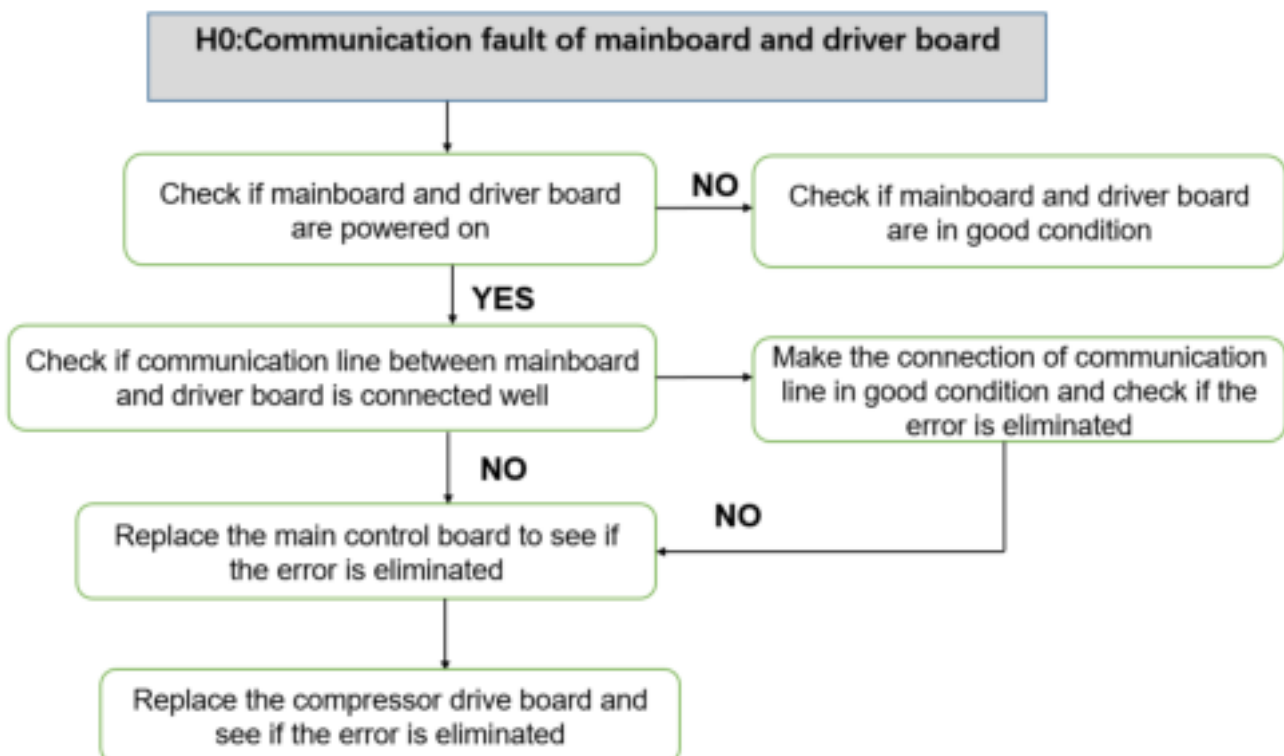

7. Error code: H4: Display P6 for 3 times within 30 mins (IPM module protection)

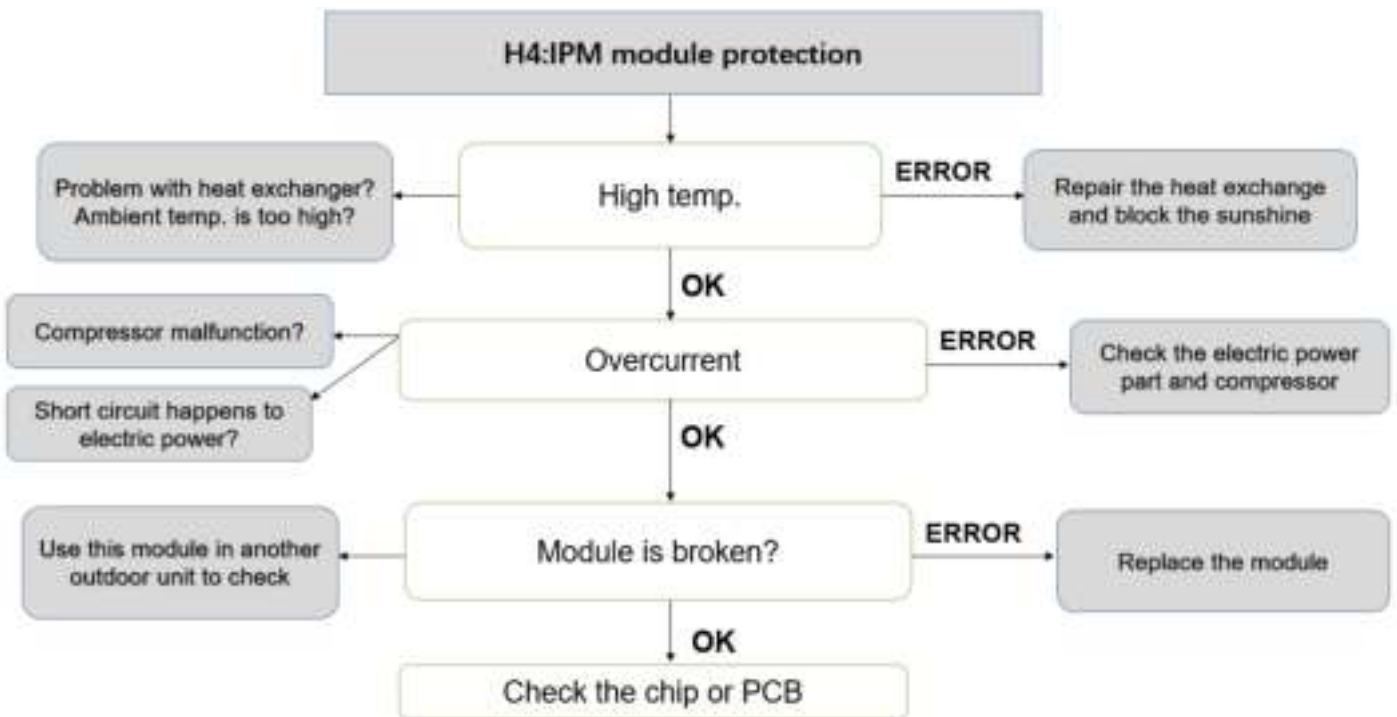

8. Error code: H5: Low pressure of system

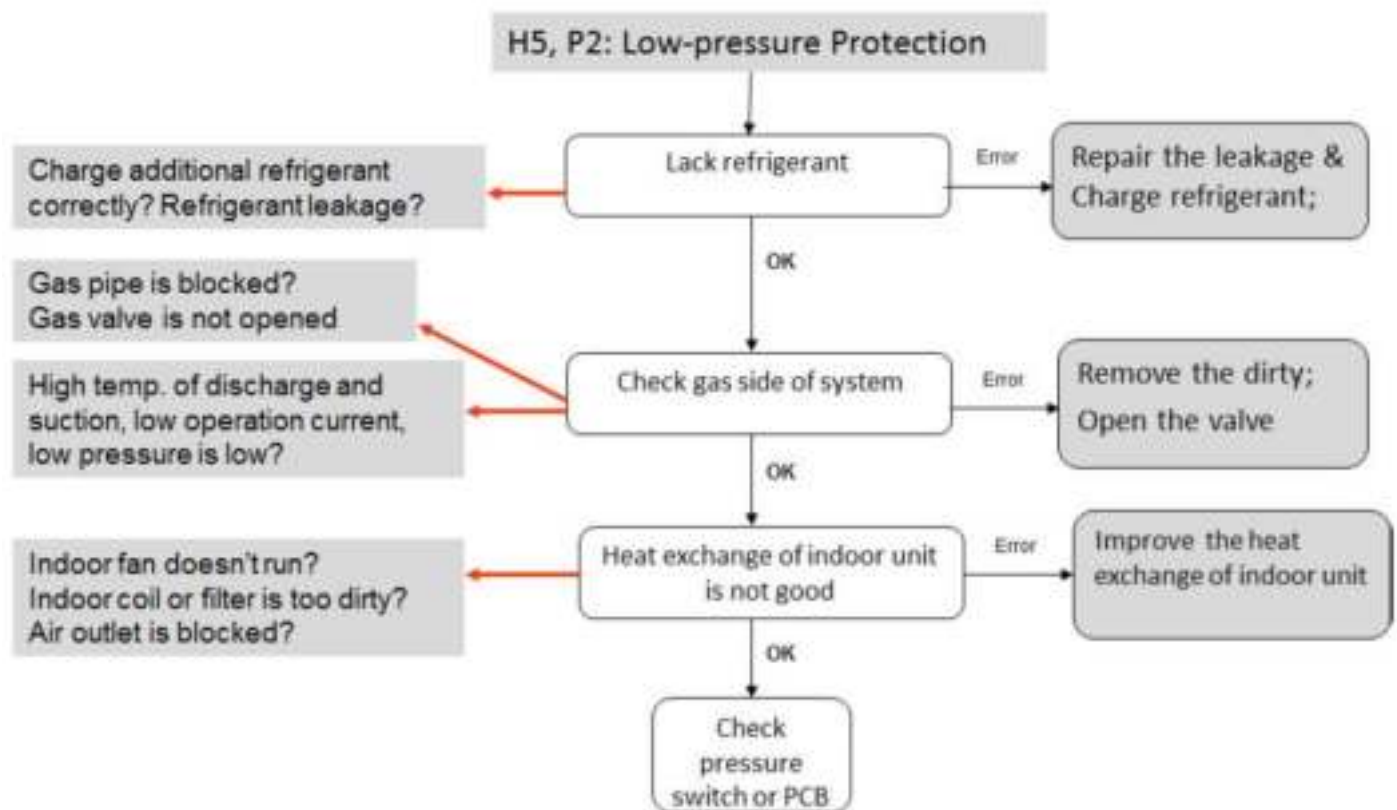

9. Error code: H6 : Display P4 for 3 times within 100 minutes (T5 Temp. is too high)

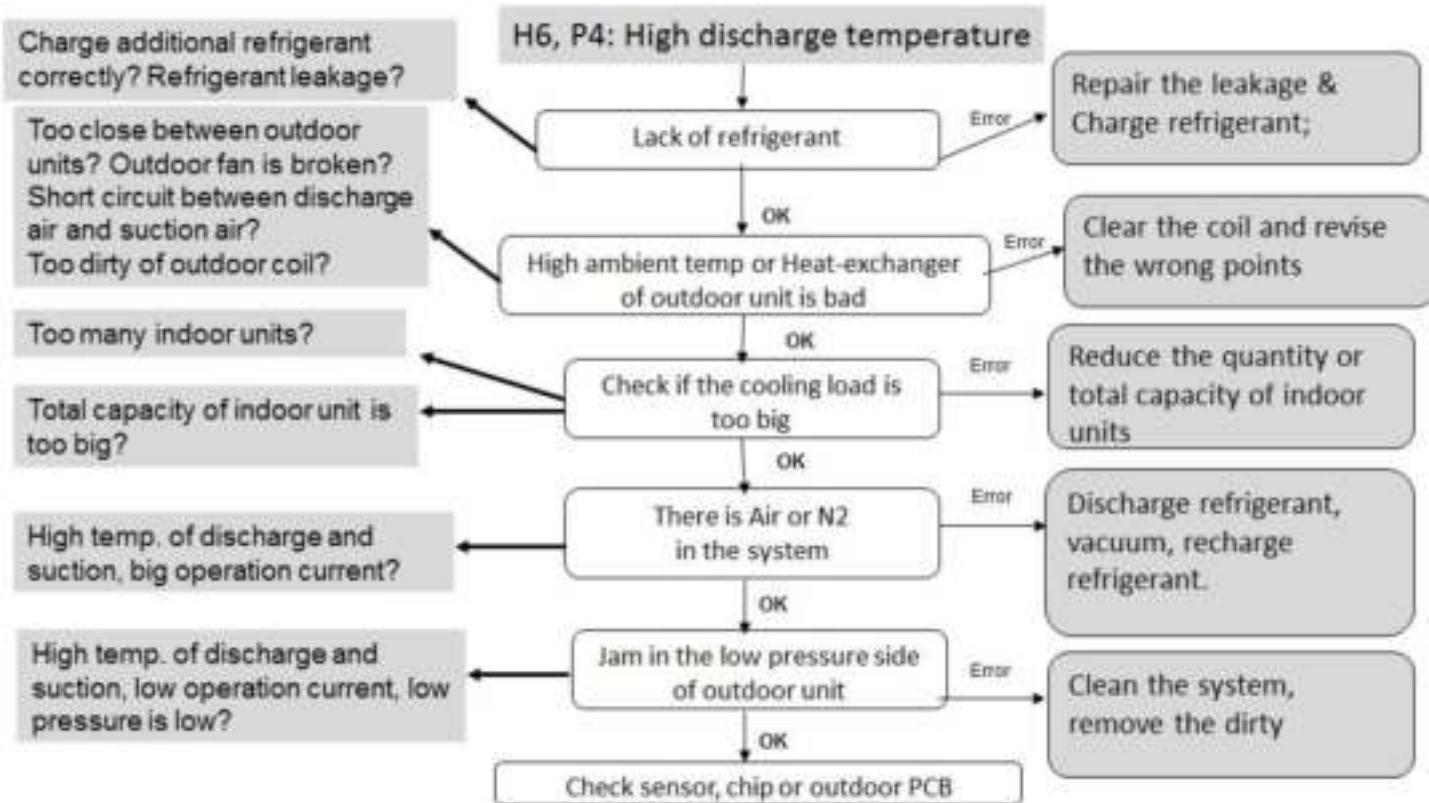

10. Error code: P1:High pressure protection

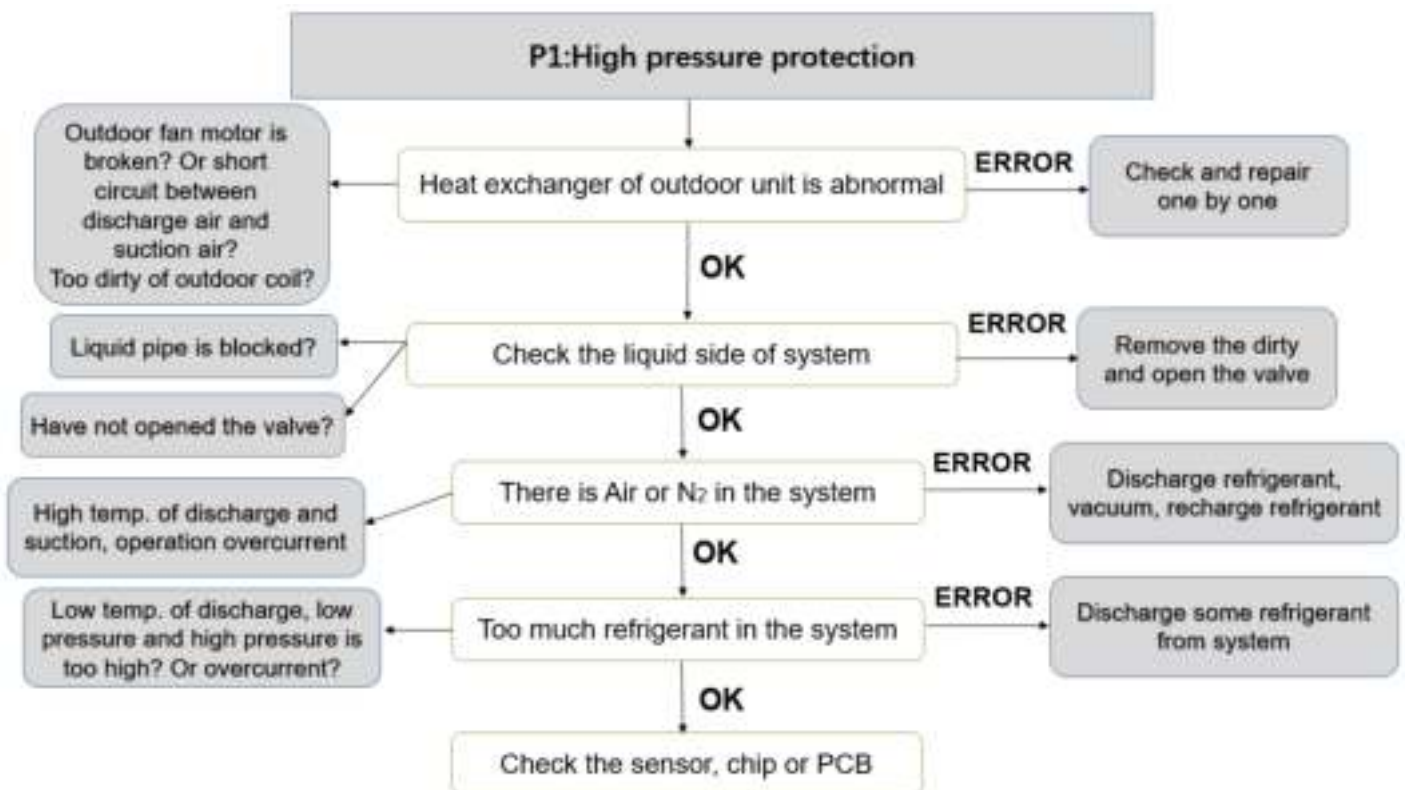

11. Error code: P2:Low pressure protection

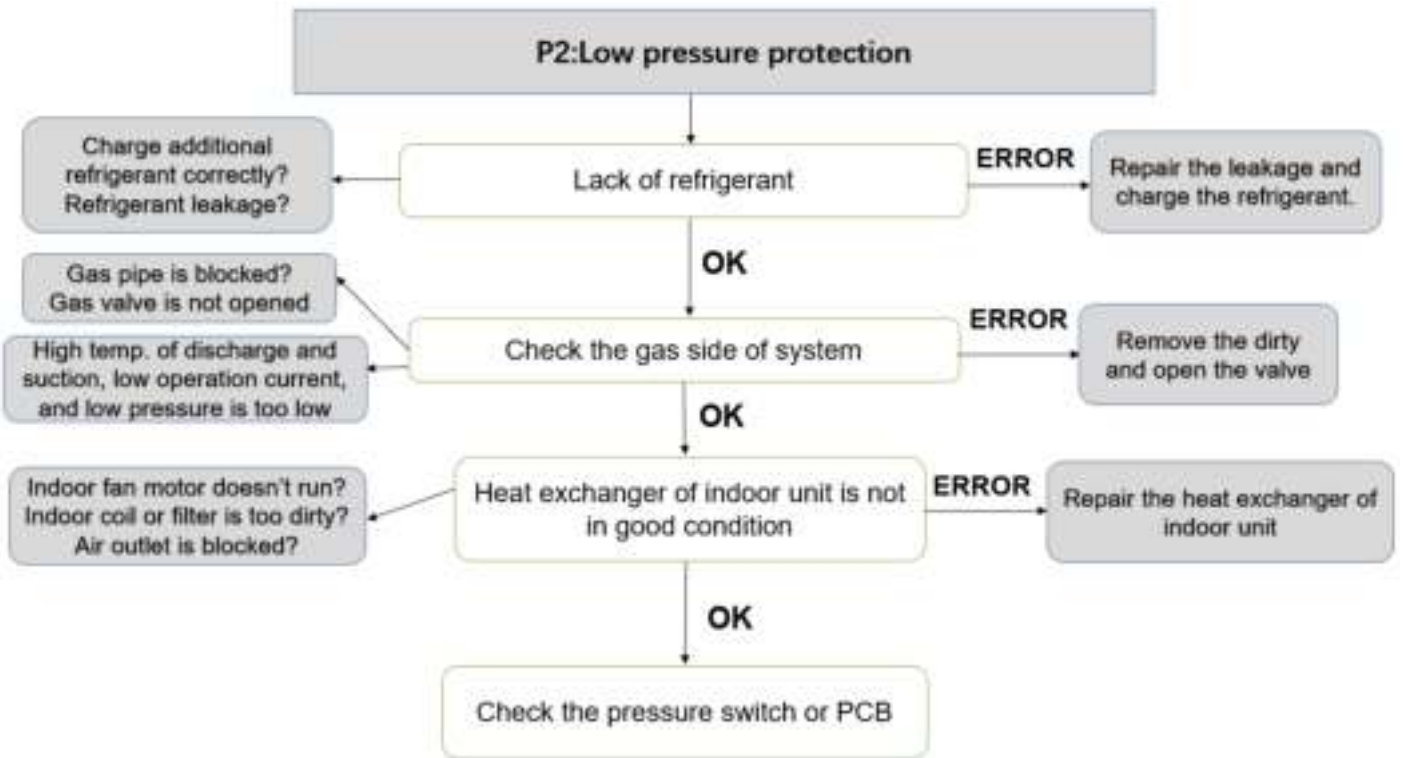

12. Error code: P3:Inverter overcurrent protection

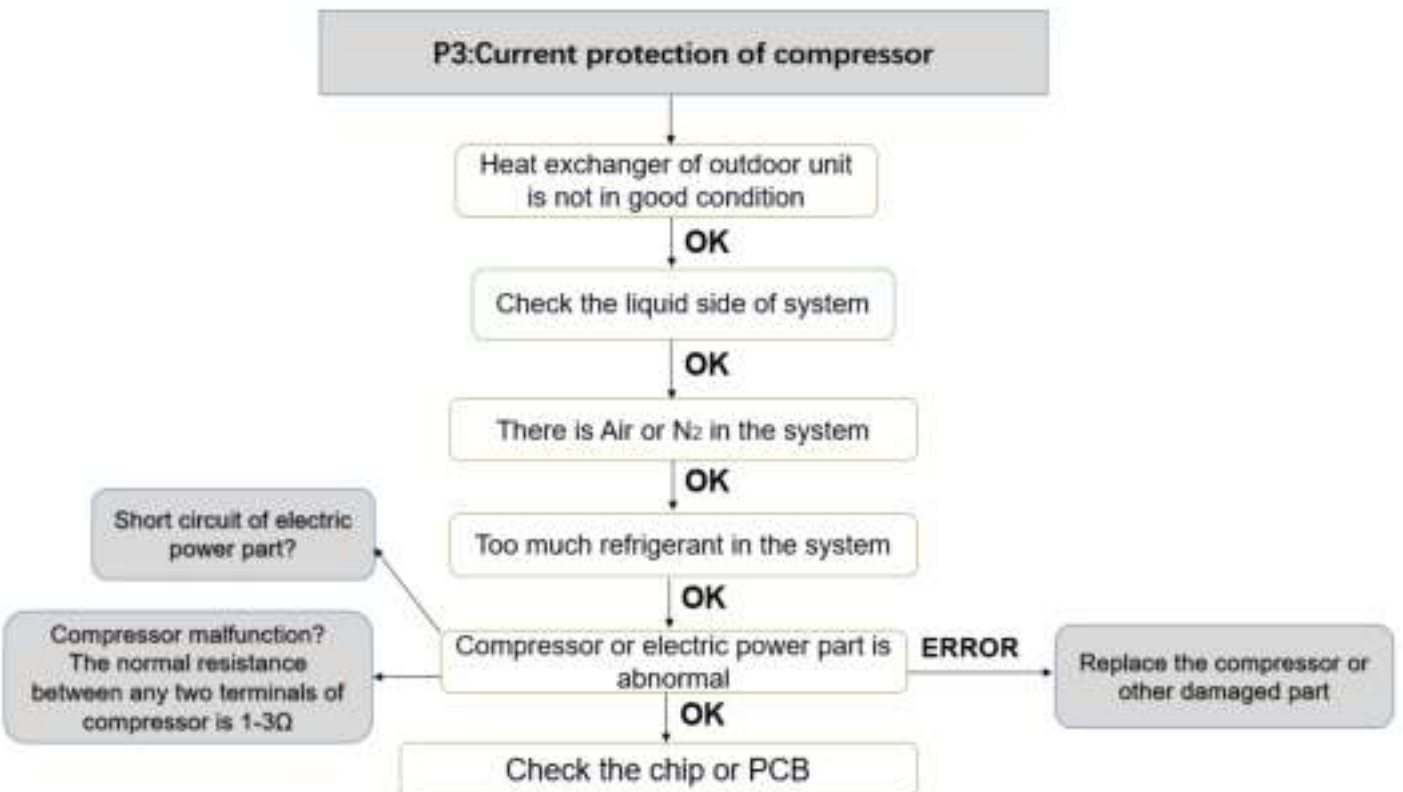

13. Error code: P4: Exhaust overheating protection

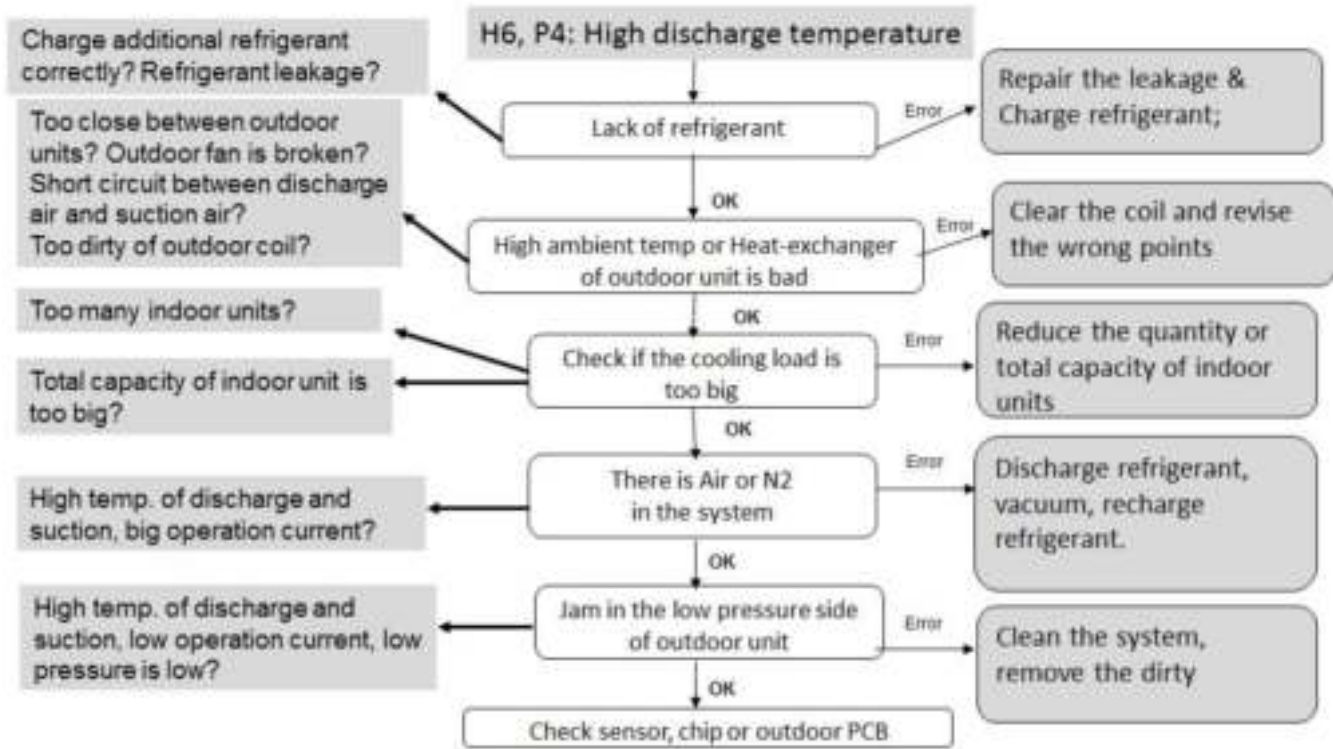

14. Error code: P5:T3 or T3B condenser pipe overheating protection

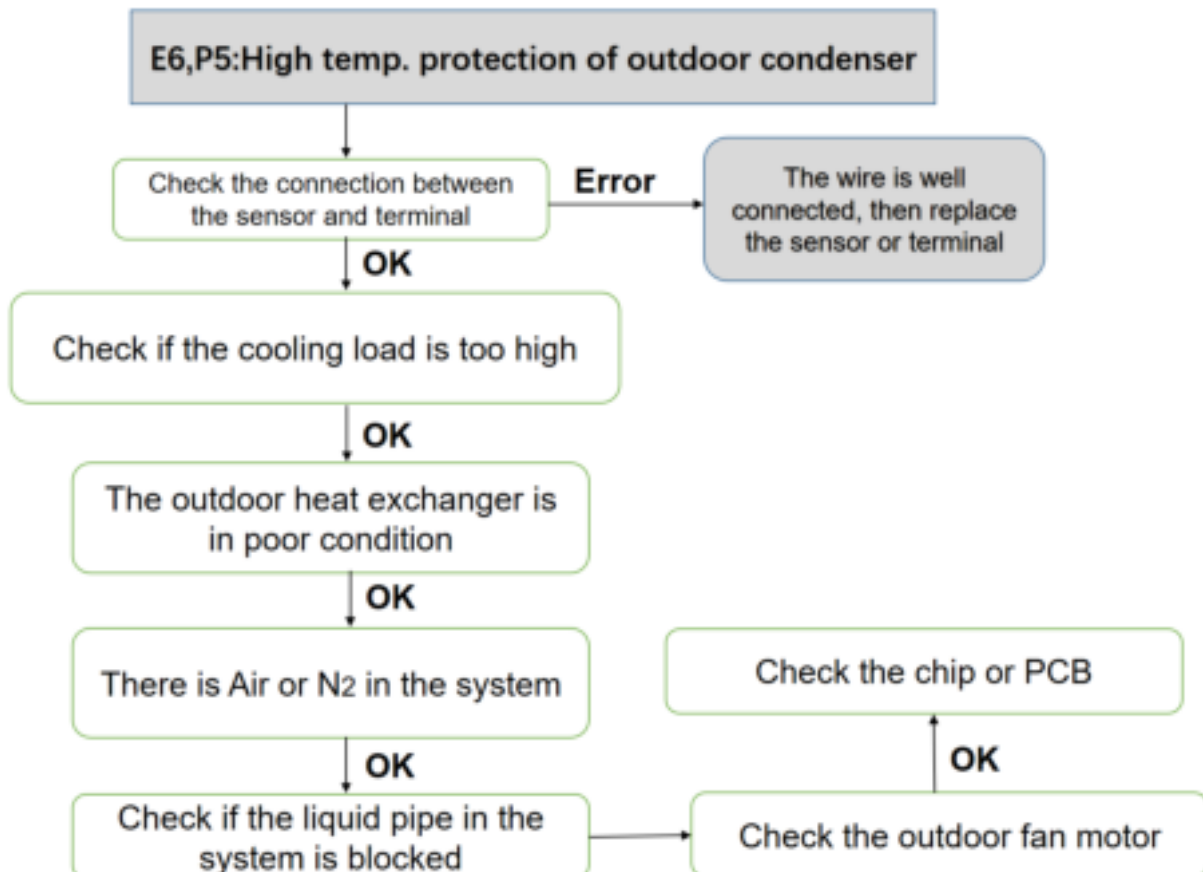

15. Error code: P6:IPM module protection

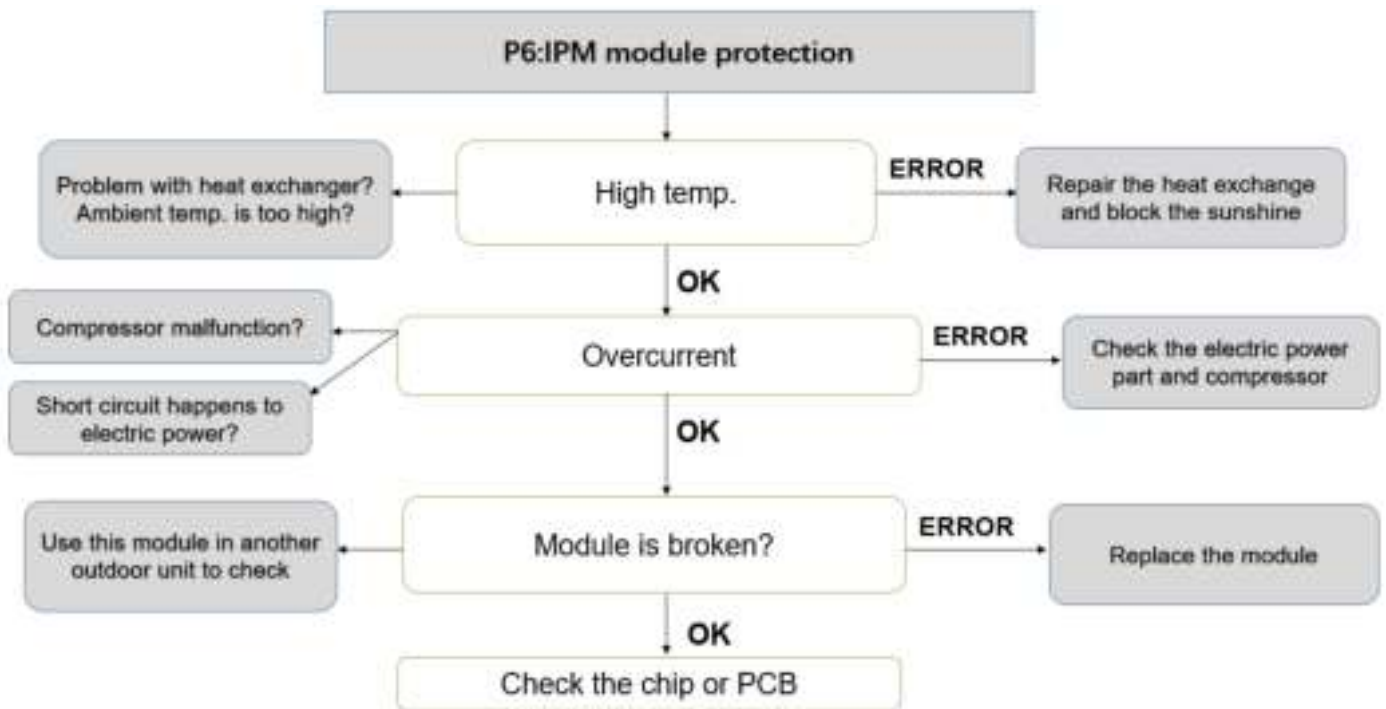

16. Error code: P9:DC fan motor fault

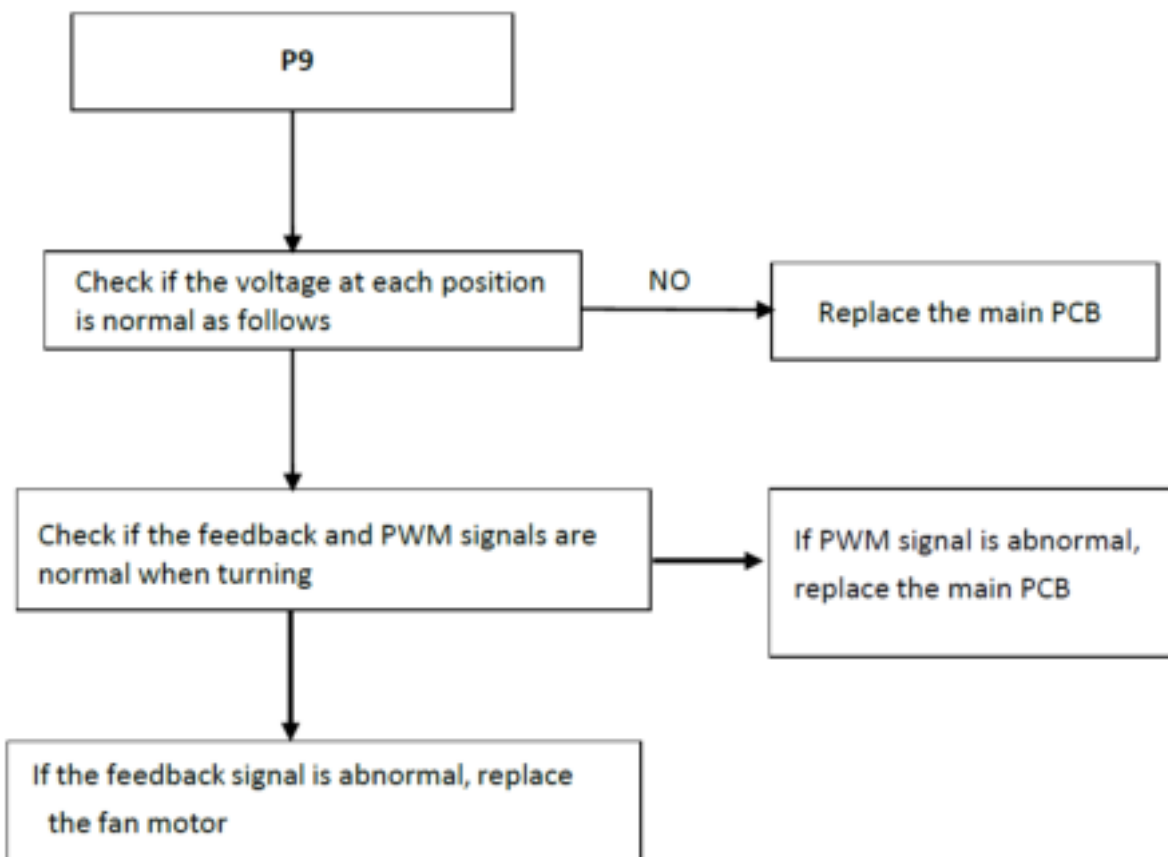

17. Error code: P11:T2 high temperature protection (Heating mode)

(1) Works:

a)When T2 averages $>63^{\circ}\text{C}$ for a period of time, stop the compressor and display error code P11 for at least 30s;

b)When T2 $<50^{\circ}\text{C}$, the protection is released.

The compressor's three-minute delay protection is effective.

(2) Effect:Prevent the four-way valve from being powered down and not recovering, jamming, or inserting the wrong end of the four-way valve.

(3) Solution:When checking the cooling, the four-way valve coil is still energized. If yes, please check if there is any problem with the coil wiring. If not, proceed to the next step.Check if the four-way valve is normal or not, and if the valve body is stuck.

Section 18. Exploded View

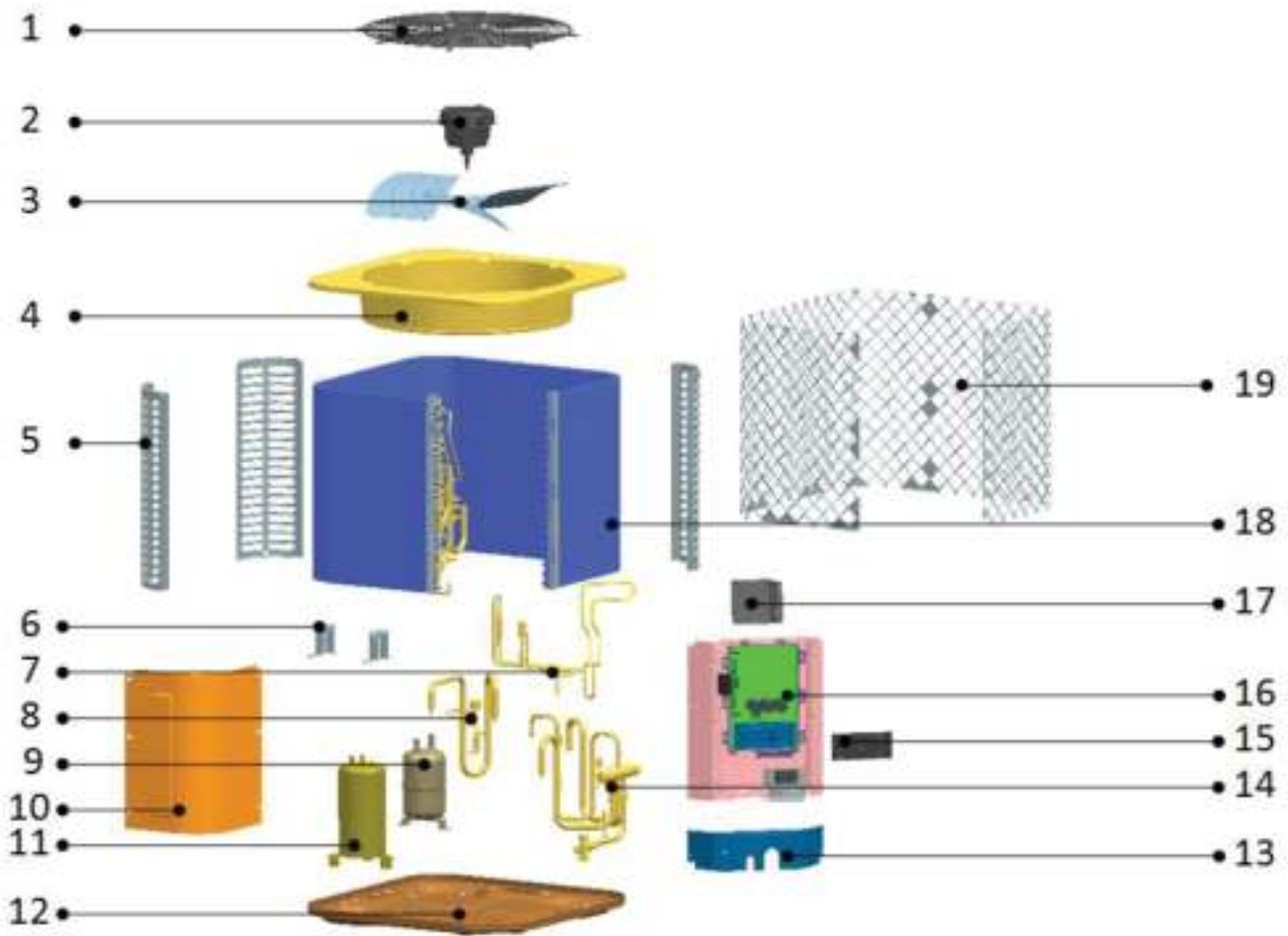

No.	Part Name	Quantity	No.	Part Name	Quantity
1	Cover net	1	14	Pipeline component	1
2	Outdoor motor	1	14.1	High pressure valve welding assembly	1
3	Axial-flow fan	1	14.1.1	High pressure valve connecting pipe	1
4	Top cover assembly	1	14.1.2	Service valve	1
5	Support board	3	15	Radiator cover	1
6	Piping support plate	2	16	Electronic components	1
7	Refrigerant radiating pipe component	1	16.1	Terminal	1
8	Air return duct welding assembly	1	16.2	Outdoor display panel	1
8.1	Solenoid Valve	1	16.3	Outdoor inverter integrated board	1
8.2	Air return duct #1	1	16.4	Reactor	1
8.3	Air return duct #2	1	16.5	Fan capacitor	1
8.4	Liquid bypass capillary assembly	1	16.6	Electronic controlled mounting plate welding parts	1
8.5	Solenoid Valve coil	1	16.7	Mainboard mounting base	1
9	Gas-liquid separator	1	16.8	Communication board mounting base	1
10	Top panel	1	16.9	Terminal mounting plate	1
11	Inverter Compressor	1	17	Reactor mounting plate	1
12	Chassis assembly	1	18	Condenser unit	1
13	Left side panel	1	19	Top discharge outdoor unit protective net	1

Section 19. Sensor Resistance

18.1. Ambient & Pipe Sensor - 5 kΩ

Temperature (°F)	Resistance Min (KΩ)	Standard (KΩ)	Resistance Max (KΩ)	Voltage value (V)	
				5V - 4.3K	
				drop down	pull up
-22	51.159	52.84	54.521	0.38	4.62
-20.2	48.659	50.232	51.805	0.39	4.61
-18.4	46.299	47.772	49.248	0.41	4.59
-16.6	44.071	45.452	46.832	0.43	4.57
-14.8	41.968	43.261	44.554	0.45	4.55
-13	39.981	41.193	42.405	0.47	4.53
-11.2	38.102	39.238	40.375	0.49	4.51
-9.4	36.326	37.391	38.457	0.52	4.48
-7.6	34.646	35.645	36.645	0.54	4.46
-5.8	33.055	33.993	34.931	0.56	4.44
-4	31.55	32.43	33.31	0.59	4.41
-2.2	30.097	30.923	31.748	0.61	4.39
-0.4	28.722	29.497	30.271	0.64	4.36
1.4	27.42	28.147	28.873	0.66	4.34
3.2	26.186	26.868	27.55	0.69	4.31
5	25.017	25.657	26.297	0.72	4.28
6.8	23.908	24.509	25.11	0.75	4.25
8.6	22.857	23.421	23.985	0.78	4.22
10.4	21.859	22.389	22.918	0.81	4.19
12.2	20.912	21.409	21.907	0.84	4.16
14	20.013	20.48	20.917	0.87	4.13
15.8	19.116	19.584	20.023	0.9	4.1
17.6	18.322	18.734	19.146	0.93	4.07
19.4	17.54	17.927	18.314	0.97	4.03
21.2	16.797	17.16	17.524	1	4
23	16.09	16.431	16.733	1.04	3.96
24.8	15.418	15.739	16.06	1.07	3.93
26.6	14.779	15.08	15.382	1.11	3.89
28.4	14.17	14.454	14.737	1.15	3.85
30.2	13.591	13.857	14.124	1.18	3.82
32	13.04	13.29	13.54	1.22	3.78
33.8	12.505	12.739	12.974	1.26	3.74
35.6	11.995	12.215	12.436	1.3	3.7
37.4	11.509	11.717	11.924	1.34	3.66
39.2	11.047	11.241	11.436	1.38	3.62
41	10.606	10.789	10.971	1.42	3.58
42.8	10.186	10.357	10.529	1.47	3.53
44.6	9.785	9.945	10.107	1.51	3.49
46.4	9.403	9.554	9.705	1.55	3.45
48.2	9.038	9.18	9.322	1.59	3.41
50	8.69	8.823	8.956	1.64	3.36
51.8	8.357	8.482	8.607	1.68	3.32
53.6	8.04	8.157	8.274	1.73	3.27
55.4	7.736	7.816	7.957	1.77	3.23
57.2	7.446	7.55	7.653	1.81	3.19
59	7.169	7.266	7.363	1.86	3.14
60.8	6.9	6.991	7.082	1.9	3.1
62.6	6.644	6.729	6.814	1.95	3.05
64.4	6.398	6.478	6.558	1.99	3.01
66.2	6.163	6.238	6.313	2.04	2.96
68	5.938	6.008	6.078	2.09	2.91
69.8	5.723	5.789	5.854	2.13	2.87
71.6	5.517	5.578	5.64	2.18	2.82
73.4	5.32	5.377	5.484	2.22	2.78
75.2	5.131	5.185	5.238	2.27	2.73
77	4.95	5	5.05	2.31	2.69

Temperature (°F)	Resistance Min (KΩ)	Standard (KΩ)	Resistance Max (KΩ)	Voltage value (V)	
				5V - 4.3K	
				drop down	pull up
78.8	4.771	4.821	4.871	2.36	2.64
80.6	4.599	4.649	4.699	2.4	2.6
82.4	4.434	4.485	4.535	2.45	2.55
84.2	4.277	4.327	4.377	2.49	2.51
86	4.126	4.176	4.226	2.54	2.46
87.8	3.981	4.031	4.081	2.58	2.42
89.6	3.842	3.892	3.942	2.62	2.38
91.4	3.709	3.759	3.808	2.67	2.34
93.2	3.581	3.631	3.68	2.71	2.29
95	3.495	3.508	3.557	2.77	2.23
96.8	3.34	3.389	3.438	2.8	2.2
98.6	3.226	3.275	3.323	2.84	2.16
100.4	3.117	3.165	3.213	2.88	2.12
102.2	3.012	3.06	3.107	2.92	2.08
104	2.912	2.959	3.006	2.96	2.04
105.8	2.815	2.861	2.908	3	2
107.6	2.722	2.768	2.814	3.04	1.96
109.4	2.633	2.678	2.724	3.08	1.92
111.2	2.547	2.592	2.637	3.12	1.88
113	2.464	2.509	2.553	3.16	1.84
114.8	2.385	2.429	2.473	3.2	1.8
116.6	2.308	2.352	2.395	3.23	1.77
118.4	2.235	2.278	2.231	3.27	1.73
120.2	2.164	2.207	2.249	3.3	1.7
122	2.096	2.138	2.18	3.34	1.66
123.8	2.03	2.071	2.112	3.37	1.63
125.6	1.966	2.006	2.047	3.41	1.59
127.4	1.904	1.944	1.984	3.44	1.54
129.2	1.844	1.884	1.923	3.48	1.52
131	1.787	1.826	1.865	3.51	1.49
132.8	1.732	1.77	1.809	3.54	1.46
134.6	1.679	1.717	1.754	3.57	1.43
136.4	1.628	1.665	1.702	3.6	1.4
138.2	1.579	1.615	1.652	3.63	1.37
140	1.531	1.567	1.603	3.66	1.34
141.8	1.485	1.521	1.556	3.69	1.31
143.6	1.441	1.476	1.511	3.72	1.28
145.4	1.399	1.433	1.467	3.75	1.25
147.2	1.357	1.391	1.425	3.78	1.22
149	1.318	1.351	1.384	3.8	1.2
150.8	1.279	1.312	1.344	3.83	1.17
152.6	1.242	1.274	1.306	3.86	1.14
154.4	1.206	1.237	1.269	3.88	1.12
156.2	1.171	1.202	1.233	3.91	1.09
158	1.137	1.168	1.199	3.93	1.07
159.8	1.105	1.135	1.165	3.96	1.04
161.6	1.074	1.103	1.133	3.98	1.02
163.4	1.043	1.072	1.101	4	1
165.2	1.014	1.043	1.071	4.02	0.98
167	0.986	1.014	1.042	4.05	0.95
168.8	0.959	0.986	1.014	4.07	0.93
170.6	0.932	0.959	0.986	4.09	0.91
172.4	0.907	0.933	0.96	4.11	0.89
174.2	0.882	0.908	0.934	4.13	0.87
176	0.858	0.884	0.91	4.15	0.85

Sensor resistance table 5kΩ

18.2. Exhaust Temperature Sensor - 50 kΩ

Temperature	Resistance	Standard	Resistance	Temperature	Resistance	Standard	Resistance
(°F)	Min (KΩ)	(KΩ)	Max (KΩ)	(°F)	Min (KΩ)	(KΩ)	Max (KΩ)
-40	1517.938	1678.646	1854.696	60.8	72.1997	75.0392	77.9201
-38.2	1422.3	1570.799	1733.241	62.6	69.0049	71.6526	74.3349
-36.4	1333.318	1470.591	1620.536	64.4	65.9692	68.4376	70.9344
-34.6	1250.488	1377.432	1515.897	66.2	63.0838	65.3846	67.7082
-32.8	1173.345	1290.783	1418.697	68	60.3405	62.4845	64.6465
-31	1101.463	1210.148	1328.359	69.8	57.7316	59.729	61.7399
-29.2	1034.452	1135.072	1244.358	71.6	55.2497	57.11	58.9799
-27.4	971.9498	1065.138	1166.209	73.4	52.888	54.6202	56.3583
-25.6	913.6268	999.9617	1093.47	75.2	50.6402	52.2524	53.8674
-23.8	859.1774	939.1908	1025.731	77	48.5	50	51.5
-22	808.3207	882.5004	962.6203	78.8	46.3805	47.8569	49.3358
-20.2	760.7977	829.5918	903.7921	80.6	44.365	45.8171	47.2741
-18.4	716.3698	780.1897	848.9302	82.4	42.4479	43.8752	45.3096
-16.6	674.8167	734.0406	797.7434	84.2	40.6238	42.0259	43.4373
-14.8	635.935	690.9108	749.9635	86	38.8878	40.2644	41.6523
-13	599.537	650.5816	705.3433	87.8	37.2351	38.5861	39.9501
-11.2	565.4492	612.8632	663.655	89.6	35.6614	36.9866	38.3265
-9.4	533.5113	577.5627	624.6886	91.4	34.1625	35.4618	36.7775
-7.6	503.575	544.5136	588.2504	93.2	32.7345	34.0079	35.2991
-5.8	475.5029	513.5589	554.1613	95	31.3736	32.6212	33.888
-4	449.1681	484.5536	522.2563	96.8	30.0763	31.2983	32.5406
-2.2	424.4528	457.3636	492.3826	98.6	28.8394	30.0359	31.2538
-0.4	401.2481	431.8647	464.399	100.4	27.6598	28.8309	30.0246
1.4	379.4528	407.9418	438.175	102.2	26.5345	27.6805	28.85
3.2	358.9732	385.4885	413.4885	104	25.4608	26.582	27.7275
5	339.7222	364.4061	390.5317	105.8	24.436	25.5326	26.6544
6.8	321.6191	344.6029	368.8969	107.6	23.4577	24.5301	25.6283
8.6	304.5889	325.9941	348.5895	109.4	22.5236	23.572	24.647
10.4	288.5618	308.5007	329.5205	111.2	21.6314	22.6562	23.7082
12.2	273.4732	292.0497	311.6074	113	20.779	21.7806	22.8099
14	259.2627	276.573	294.7735	114.8	19.9645	20.9433	21.9502
15.8	245.8743	262.0074	278.9478	116.6	19.1861	20.1424	21.1273
17.6	233.2557	248.2941	264.0642	118.4	18.4419	19.3761	20.3393
19.4	221.3586	235.3787	250.0615	120.2	17.7302	18.6428	19.5847
21.2	210.1374	223.2101	236.8825	122	17.0496	17.9409	18.8618
23	199.5502	211.741	224.4743	123.8	16.3979	17.2683	18.1686
24.8	189.5576	200.9274	212.7875	125.6	15.7745	16.6244	17.5045
26.6	180.1229	190.7282	201.7763	127.4	15.1782	16.008	16.8682
28.4	171.2119	181.1052	191.3977	129.2	14.6075	15.4177	16.2584
30.2	162.7926	172.0225	181.6121	131	14.0612	14.8522	15.6738
32	154.8353	163.447	172.3824	132.8	13.5383	14.3105	15.1133
33.8	147.2927	155.3267	163.6515	134.6	13.0375	13.7913	14.5758
35.6	140.1617	147.6573	155.4138	136.4	12.5579	13.2937	14.0602
37.4	133.4176	140.4114	147.6388	138.2	12.0984	12.8167	13.5656
39.2	127.0372	133.5631	140.2978	140	11.6581	12.3592	13.0909
41	120.999	127.0885	133.3643	141.8	11.2361	11.9204	12.6353
42.8	115.2827	120.9652	126.8134	143.6	10.8315	11.4994	12.1978
44.6	109.8694	115.172	120.62.19	145.4	10.4436	11.0955	11.7778
46.4	104.7414	109.6896	114.7681	147.2	10.0715	10.7078	11.3744
48.2	99.882	104.4994	109.2318	149	9.7146	10.3357	10.9868
50	95.2758	99.5843	103.991	150.8	9.3722	9.9784	10.6145
51.8	90.9081	94.9283	99.037	152.6	9.0436	9.6352	10.2566
53.6	86.7654	90.5162	94.3442	154.4	8.7281	9.3056	9.9126
55.4	82.8348	86.3341	89.9002	156.2	8.4253	8.9889	9.5819
57.2	79.1044	82.3687	85.6905	158	8.1344	8.6846	9.2639
59	75.5629	78.6076	81.7013				

Sensor resistance table 50kΩ

Continued - Exhaust Temperature Sensor - 50 kΩ

Temperature	Resistance	Standard	Resistance	Temperature	Resistance	Standard	Resistance
(°F)	Min (KΩ)	(KΩ)	Max (KΩ)	(°F)	Min (KΩ)	(KΩ)	Max (KΩ)
159.8	7.8551	8.3921	8.9581	260.6	1.4306	1.5803	1.744
161.6	7.5868	8.111	8.6638	262.4	1.3931	1.5397	1.7001
163.4	7.3289	7.8406	8.3807	264.2	1.3568	1.5003	1.6575
165.2	7.0812	7.5807	8.1083	266	1.3216	1.4621	1.6162
167	6.843	7.3306	7.8461	267.8	1.2874	1.4251	1.576
168.8	6.614	7.09	7.5936	269.6	1.2543	1.3891	1.537
170.6	6.3938	6.8585	7.3506	271.4	1.2221	1.3542	1.4992
172.4	6.182	6.6357	7.1164	273.2	1.191	1.3203	1.4624
174.2	5.9782	6.4212	6.891	275	1.1607	1.2874	1.4267
176	5.7822	6.2147	6.6737	276.8	1.1313	1.2555	1.392
177.8	5.5936	6.0159	6.4644	278.6	1.1028	1.2245	1.3583
179.6	5.412	5.8243	6.2626	280.4	1.0752	1.1944	1.3256
181.4	5.2372	5.6398	6.0681	282.2	1.0483	1.1651	1.2938
183.2	5.0689	5.4621	5.8806	284	1.0223	1.1367	1.2628
185	4.9068	5.2908	5.6998				
186.8	4.7506	5.1257	5.5254				
188.6	4.6002	4.9665	5.3572				
190.4	4.4553	4.8131	5.195				
192.2	4.3156	4.6651	5.0384				
194	4.181	4.5224	4.8873				
195.8	4.0512	4.347	4.7414				
197.6	3.926	4.2518	4.6006				
199.4	3.8053	4.1236	4.4646				
201.2	3.6889	3.9999	4.3333				
203	3.5766	3.8805	4.2064				
204.8	3.4682	3.7652	4.0839				
206.6	3.3637	3.6538	3.9655				
208.4	3.2627	3.5463	3.8511				
210.2	3.1653	3.4424	3.7405				
212	3.0712	3.3421	3.6336				
213.8	2.9803	3.2451	3.5302				
215.6	2.8925	3.1513	3.4302				
217.4	2.8077	3.0607	3.3335				
219.2	2.7258	2.9731	3.24				
221	2.6466	2.8884	3.1495				
222.8	2.5701	2.8065	3.062				
224.6	2.4961	2.7273	2.9773				
226.4	2.4246	2.6507	2.8953				
228.2	2.3555	2.5766	2.8159				
230	2.2886	2.5049	2.7391				
231.8	2.2239	2.4355	2.6647				
233.6	2.1614	2.3683	2.5926				
235.4	2.1009	2.3033	2.5229				
237.2	2.0423	2.2403	2.4553				
239	1.9856	2.1794	2.3898				
240.8	1.9308	2.1203	2.3263				
242.6	1.8777	2.0632	2.2648				
244.4	1.8263	2.0078	2.2053				
246.2	1.7766	1.9541	2.1475				
248	1.7284	1.9021	2.0915				
249.8	1.6817	1.8518	2.0372				
251.6	1.6365	1.8029	1.9845				
253.4	1.5927	1.7556	1.9335				
255.2	1.5502	1.7097	1.8839				
257	1.5091	1.6653	1.8359				
258.8	1.4692	1.6221	1.7893				

Sensor resistance table 50kΩ